

IBEA

Modello n. 2035

Serie: dal n. 1001

Stampato n. P5090120

LISTA RICAMBI

SPARE PART LIST

ERSATZTEILLISTE

LISTE DES PIECES DE RECHANGE



TURBO 50

REF. N°	PART. N°	QTY	DESCRIZIONE	DESCRIPTION	DESCRIPTION	BESCHREIBUNG
1	P5140015	1	DECALCO	DECAL	MARQUAGE	AUFKLEBER
2	P5140193	1	DECALCO	DECAL	MARQUAGE	AUFKLEBER
3	P5140198	1	DECALCO	DECAL	MARQUAGE	AUFKLEBER
4	P5140199	1	DECALCO	DECAL	MARQUAGE	AUFKLEBER
5	P5140200	1	DECALCO	DECAL	MARQUAGE	AUFKLEBER
6	P5140201	1	DECALCO	DECAL	MARQUAGE	AUFKLEBER
7	P5140515	1	DECALCO	DECAL	MARQUAGE	AUFKLEBER
*	P5110008	1	CHIAVE TUBO	KEY	CLEF	SCHLUSSEL
*	P5090105	1	MANUALE	INSTRUCTION MANUAL	MODE D'EMPLOI	BEDIENUNGSANLEITUNG



1



2

IBEA

3



Vor arbeiten am gerät zündkerzenstecker abziehen.
Sack nicht antippen oder öffnen, so lange maschine läuft
Vor dem betrieb saugöffnung verschließen oder fangstutzen und fangrohr sowie fangsack montieren.

Avant d'amorcer le travail à la machine, retirez la câble d'allumage.
Ne retirez ou n'ouvrez pas le sac avant l'immobilisation du moteur.

Fermez l'ouverture d'admission ou montez une pièce de raccordement et un tube d'aspiration. Avant utilisation, fixez le sac à l'éjection.

Rimuovere la candela prima di qualsiasi intervento di manutenzione o riparazione.
Non rimuovere o aprire il cestello prima che il motore si è arrestato.
Chiudere l'apertura di entrata o montare il tubo di aspirazione ed il cestello prima di adoperare la macchina.

4



Remove spark plug lead prior to working on unit.
Do not remove or open bag prior to stopping engine.
Close inlet opening or assemble connecting piece and suction tube and fasten bag on chute prior to operation.

Koppel de ontsleingskabel los vooraleer U werkzaamheden aan de machine verricht.
Verwijder of open de bak niet vooraleer U de motor hebt stopgezet.

Sluit de inlaatopening of monteer het kussenstuk en de aanzuigtube en sluit de linnen bak voor het gebruik.

Avant d'amorcer le travail à la machine, retirez la câble d'allumage.
Ne retirez ou n'ouvrez pas le sac avant l'immobilisation du moteur.
Fermez l'ouverture d'admission ou montez une pièce de raccordement et un tube d'aspiration. Avant utilisation, fixez le sac à l'éjection.



5



6



Attrezzo in movimento. L'attrezzo continua a rotare dopo che il motore viene spento.

Umlaufendes werkzeug. Werkzeug läuft nach!

Tool in motion. Tool continues to rotate after engine is switched off!

Outil de travail en mouvement. L'outil de travail continue de tourner après que le moteur été coupé.

Het werktuig blijft roteren nadat de motor werd afgezet.

7

REF. N°	PART. N°	QTY	DESCRIZIONE	DESCRIPTION	DESCRIPTION	BESCHREIBUNG
1		1	MOTORE	ENGINE	MOTEUR	MOTOR
2	P020684102Vt	1	STEGOLA INFERIORE	LOWER HANDLEBAR COMPL.	GUIDON INFÉRIEUR COMPL.	HOLMUNTERTEIL KOMP.
3	P1050011	6	DADO	NUT	ECROU	MUTTER
4	P1010134	2	VITE	SCREW	VIS	SCHRAUBE
5	P020300102Zn	1	ASSALE POSTERIORE	REAR AXLE	ESSIEU ARRIÈRE	HINTERACHSE
6	P1010119	4	VITE	SCREW	VIS	SCHRAUBE
7	P1010110	4	VITE	SCREW	VIS	SCHRAUBE
8	P1020050	2	RONDELLA	SPRING WASHER	RONDELLE ÉLASTIQUE	FEDERSCHEIBE
9	P2020088	2	DISTANZIALE	SPACER	RONDELLE	DISTANZBUCHSE
10	P00015003	2	RUOTA	WHEEL	ROUE	RAD
11	P3030013	4	CUSCINETTO	BEARING	PALIER	LAGER
12	1020007A1	1	RONDELLA	WASHER	RONDELLE	SCHEIBE
13	1010018A1	2	VITE	SCREW	VIS	SCHRAUBE
14	P2020333	2	COPRIMOZZO POST.	REAR COVER	COUVERCLE ARRIÈRE	DECKEL
15	P2020334	2	COPRIMOZZO ANT.	FRONT COVER	COUVERCLE ANTÉRIEUR	DECKEL
16	1010018A1	2	VITE	SCREW	VIS	SCHRAUBE
17	1020007A1	2	RONDELLA	WASHER	RONDELLE	SCHEIBE
18	P3030013	4	CUSCINETTO	BEARING	PALIER	LAGER
19	P2020200	2	RUOTA	WHEEL	ROUE	RAD
20	P1020083	4	MOLLA	SPRING	RESSORT	FEDER
21	P1010120	2	VITE	SCREW	VIS	SCHRAUBE
22	1020014A1	2	RONDELLA	WASHER	RONDELLE	SCHEIBE
23	P4020131	2	PORTA RUOTA	PIVOT ARM	SUPPORT	TRAEGER
24	P2020077	2	POMELLO LEVA	KNOB	POIGNÉE	ABDECKUNG
25	P1020064	4	RIVETTO	RIVET	RIVET	NIET
26	P4010139	2	LEVA ALZARUOTA	LEVER	LEVIER	HEBEL
27	P3040251	2	BUSSOLA	BUSHING	DOUILLE	BUECHSE
28	P4010132	2	PIASTRA REG. TAGLIO	PLATE	PLAQUE	BLECH
29	P1010172	8	VITE	SCREW	VIS	SCHRAUBE
30	P1020088	20	RONDELLA	WASHER	RONDELLE	SCHEIBE
31	P4010166ZN	2	PIASTRA RINFORZO	REINFORCEMENT PLATE	PLAQUE DE RENFORCEMENT	VERSTAERKUNGSPLATTE
32	P1050011	6	DADO	NUT	ECROU	MUTTER
33	1050002A1	13	DADO	NUT	ECROU	MUTTER
34	P4010167ZN	1	PIASTRINA	PLATE	PLAQUE	PLATTE
35	P4010185ZT	1	PIASTRINA	PLATE	PLAQUE	PLATTE
36	P4010168ZN	1	PIASTRINA	PLATE	PLAQUE	PLATTE
37	P4010169ZN	1	LAMIERA RINFORZO	REINFORCEMENT PLATE	PLAQUE DE RENFORCEMENT	VERSTAERKUNGSPLATTE
38	P1010170	1	VITE	SCREW	VIS	SCHRAUBE
39	P1020067	1	RONDELLA	WASHER	RONDELLE	SCHEIBE
40	P001017012BI	1	VENTOLA	FAN	SOUFFLERIE	GEBLAESE
41	P1010092	2	VITE	SCREW	VIS	SCHRAUBE
42	P1010175	1	VITE	SCREW	VIS	SCHRAUBE
43	P4010193ZN	1	ANELLO RINFORZO	REINFORCEMENT RING	ANNEAU DE RENFORCEMENT	VERSTAERKUNGSRING
44	P2020197	1	COPERCHIO SCOCCA	ADDITIONAL PLUG	FICHE ADDITIONNELLE	STOPFEN
45	P2020201	1	POMELLO	KNOB	POIGNÉE	MUTTER
46	P000050102	1	SCOCCA	DECK	CHASSIS	GEHAUSE
47	P1020064	3	RIVETTO	RIVET	RIVET	NIET
48	P4030017VE.	1	CONVOGLIATORE	CONVEYOR	CONVOYEUR	FOERDERER
49	1090001A1	1	CHIAVE WOODRUFF	KEY	CLAVETTE	SCHEIBENFEDER
50	P1020080	3	RONDELLA	WASHER	RONDELLE	SCHEIBE
51	P1050011	3	DADO	NUT	ECROU	MUTTER
52	P2020165	1	CAPOTTINA MOTORE	ENGINE COVER	COUVERCLE MOTEUR	MOTORABDECKUNG
53	P1010154	2	VITE	SCREW	VIS	SCHRAUBE
54	P1010174	5	VITE	SCREW	VIS	SCHRAUBE
55	P3160044	1	SACCO RACCOGLITORE	COLLECTION BAG	SAC DE RAMASSAGE	FANGSACK
56	P000151102	2	RUOTA ANTER. COMPL.	WHEEL ASS. Y	ROUE COMPL.	RAD KOMP.
57	P000152102	2	RUOTA POSTER. COMPL.	WHEEL ASS. Y	ROUE COMPL.	RAD KOMP.
58	IB-2015	1	KIT SACCO ANTIPOLVERE	NO-DUST BAG	SAC ANTIPOUSSIÈRE	STAUBDICHTER SACK

P0010170102BI

Vista stegola superiore e comandi

Upper handle and controls

Mancheron partie supérieur et éléments de commande

Lenkeroberteil und Bedienungselemente

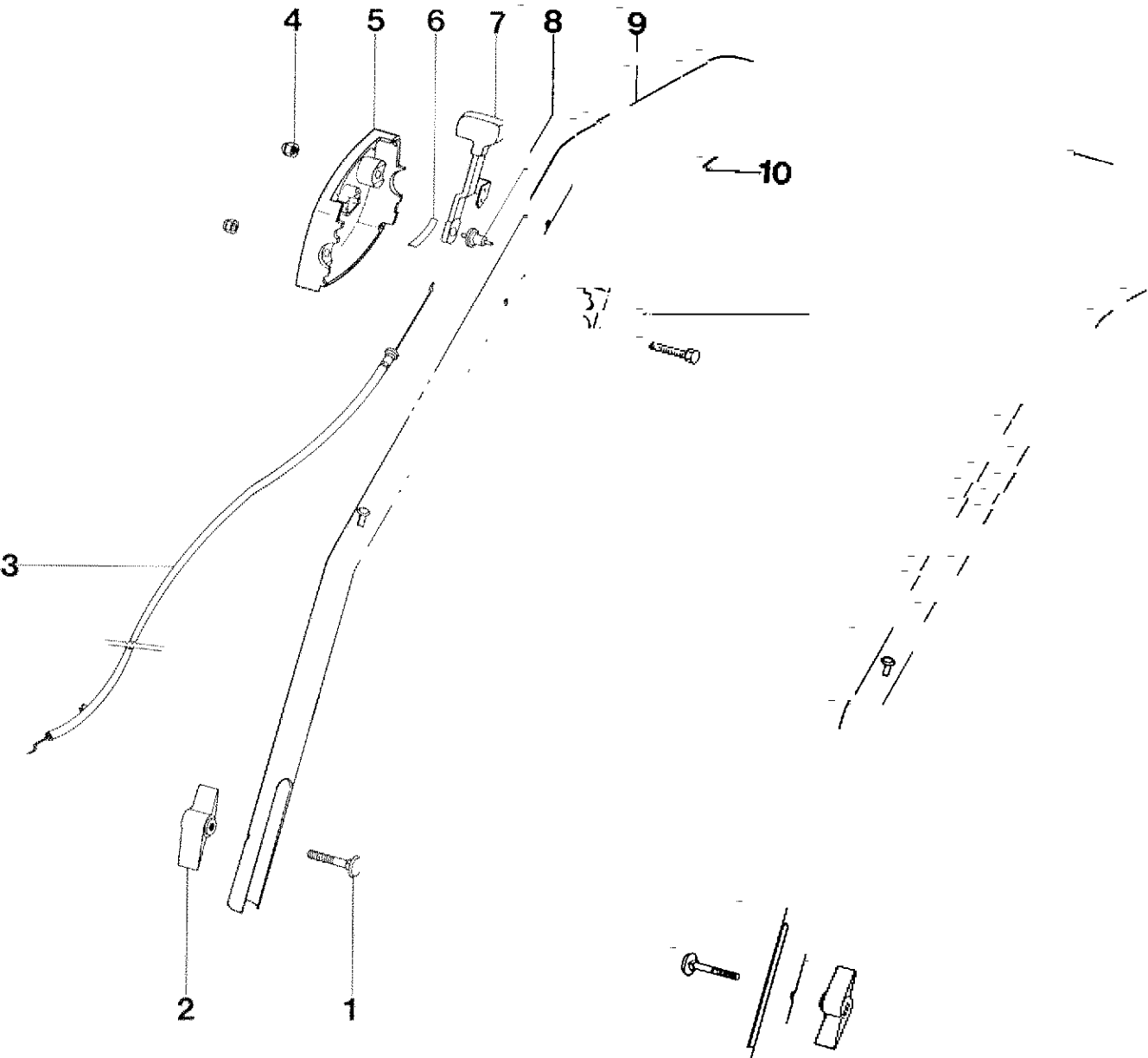

REF. N°	PART. N°	QTY	DESCRIZIONE	DESCRIPTION	DESCRIPTION	BESCHREIBUNG
1	1010026A1	2	VITE	SCREW	VIS	SCHRAUBE
2	2020050A1	2	POMELLO	KNOB	POIGNÉE	MUTTER
3	P5020055	1	CAVO ACCELERATORE	THROTTLE CABLE	CABLE DE GAZ	GASHEBEL
4	1050003A1	2	DADO	NUT	ECROU	MUTTER
5	P2020106	1	SCATOLA ACCELER. DX	R.H. HOUSING	BOITE DROITE	SCHALE R.
6	P4010059	2	MOLLA	SPRING	RESSORT	FEDER
7	P00065099	1	LEVA ACCELERATORE	THROTTLE LEVER	LEVIER DE GAZ	GASHEBEL
8	P2020108	1	NOTTOLINO	BOLT	BOULON	STIFT
9	P3120073VE	1	STEGOLA SUP.	UPPER HANDLEBAR	GUIDON SUP.	OB. FUEHRUNGSHOLM
10	P5140515	1	DECALCO	DECAL	MARQUAGE	AUFKLEBER
11	P1010102	2	VITE	SCREW	VIS	SCHRAUBE

Tav. 3

Kit aspirazione IB-2010
 Vacuum kit IB-2010
 Vacuum kit IB-2010
 Saug-ausstattung IB-2010

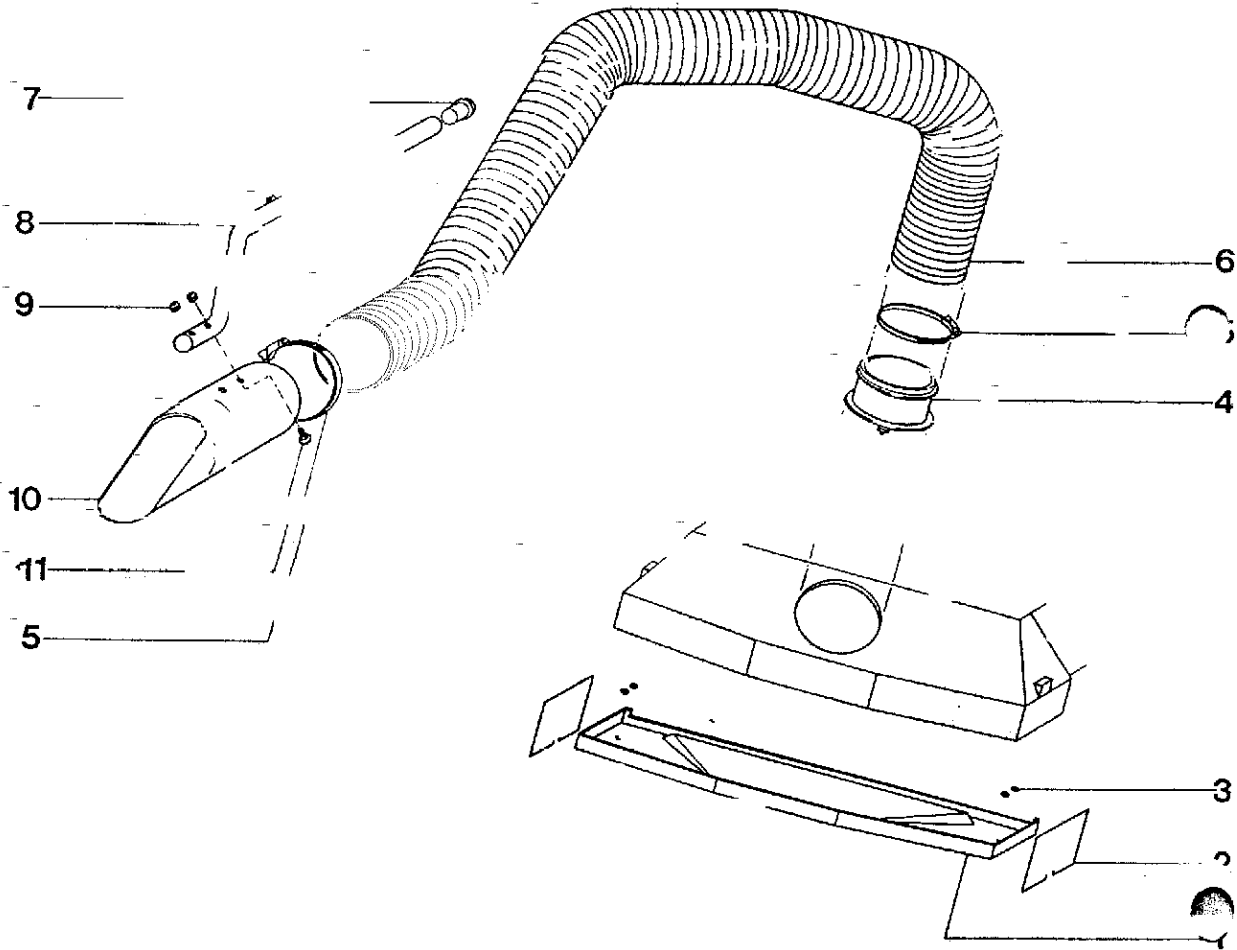

REF. N°	PART. N°	QTY	DESCRIZIONE	DESCRIPTION	DESCRIPTION	BESCHREIBUNG
1	P2020208	1	CARTER CHIUSURA	FUNNEL HOUSING	COUVERCLE EMBOUT	TRICHTERGEHAEUSE
2	P3020029	2	MOLLA	SPRING	RESSORT	FEDER
3	P1020012	4	STARLOCK	STARLOCK	STARLOCK	STARLOCK
4	P2020196	1	ATTACCO RAPIDO	COUPLING	COUPLAGE	ANSCHLUSSTEIL
5	P5040004	2	FASCETTA	CLAMP	CLIP	HALTER
6	P2020209	1	TUBO ASPIRAZIONE	INTAKE HOSE	TUYAU D'ASPIRATION	SAUGSCHLAUCH
7	P2020137	1	TAPPO	PLUG	BOUCHON	STOEPESEL
8	P3120074VE	1	MANICO BOCCHETTONE	HANDLE	MANCHON	HOLM
9	1050002A1	2	DADO	NUT	ECROU	MUTTER
10	P2020210	1	BOCCHETTONE ASPIR.	FUNNEL	EMBOUT	SAUGDUESE
11	1010002A1	2	VITE	SCREW	VIS	SCHRAUBE

P1060013

P1050007

P1010078

Vista generale
Complete machine
Vue d'ensemble
Gesamtansicht

