

# IBEA

Modello n. 2035

Serie dal n. 1001

Stampato n. P5090173 (Revisione)

**LISTA RICAMBI**

**SPARE PARTS LIST**

**ERSATZTEILLISTE**

**LISTE DES PIECES DE RECHANGE**

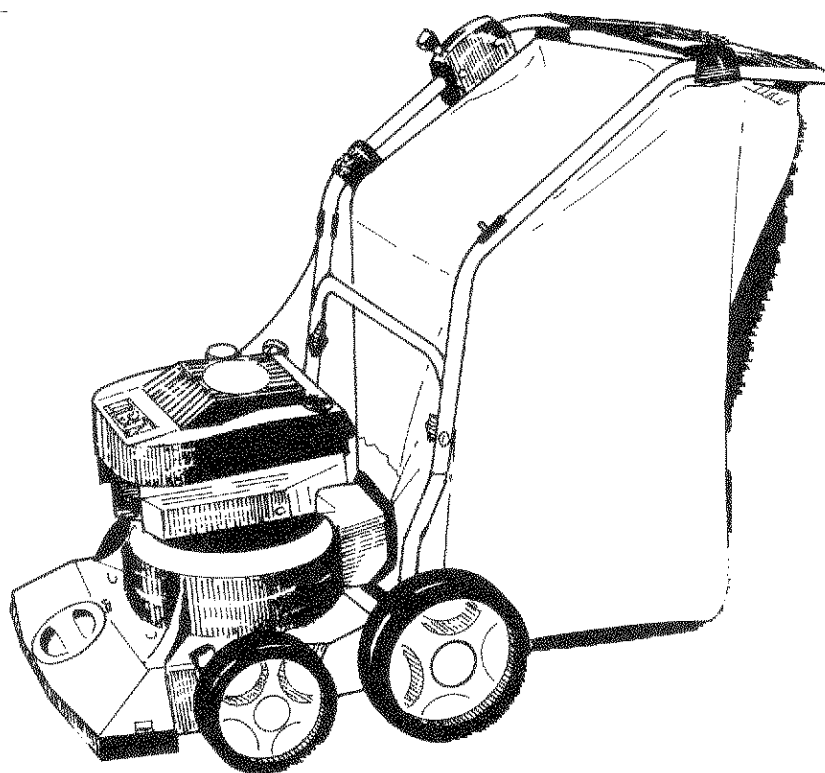

**TURBO 50**

REF. N°	PART. N°	QTY	DESCRIZIONE	DESCRIPTION	DESCRIPTION	BESCHREIBUNG
1	P5140016	1	DECALCO	DECAL	MARQUAGE	AUFKLEBER
2	P5140193	1	DECALCO	DECAL	MARQUAGE	AUFKLEBER
3	P5140308	1	DECALCO	DECAL	MARQUAGE	AUFKLEBER
4	P5140199	1	DECALCO	DECAL	MARQUAGE	AUFKLEBER
5	P5140200	1	DECALCO	DECAL	MARQUAGE	AUFKLEBER
6	P5140201	1	DECALCO	DECAL	MARQUAGE	AUFKLEBER
7	P5140583	1	DECALCO	DECAL	MARQUAGE	AUFKLEBER
*	P2020080	1	FERMACAVO	CLIP	CLIP	HALTER
*	P5110008	1	CHIAVE TUBO	KEY	CLEF	SCHLÜSSEL
*	P5090105	1	MANUALE	INSTRUCTION MANUAL	MODE D'EMPLOI	BEDIENUNGSANLEITUNG



1

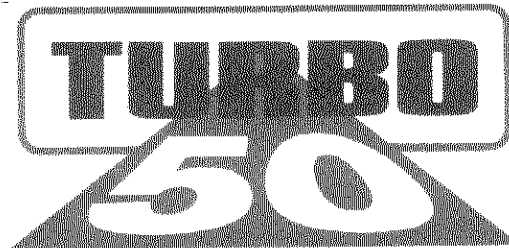

2



3



Vor arbeiten am gerät zündkerzenstecker abziehen.  
Sack nicht anfertnen oder öffnen, so lange maschine läuft.  
Vor dem betrieb saugöffnung verschließen oder fangstutzen und tangrohr sowie fangsack montieren.

Avant d'antamer le travail à la machine, retirez le câble d'allumage.  
Ne retirez ou n'ouvrez pas le sac avant l'immobilisation du moteur.

Fermez l'ouverture d'admission ou montez une pièce de raccordement et un tube d'aspiration. Avant utilisation, fixez le sac à l'éjection.

Rimuovere la candela prima di qualsiasi intervento di manutenzione o riparazione.  
Non rimuovere o aprire il cestello prima che il motore si è arrestato.  
Chudere l'apertura di entrata o montare il tubo di aspirazione ed il cestello prima di adoperare la macchina.

4



Remove spark plug lead prior to working on unit.  
Do not remove or open bag prior to stopping engine.  
Close inlet opening or assemble connecting piece and suction tube and fasten bag on chute prior to operation.

Koppel oe ontstekingskabel los vooraleer U werkzaamheden aan de machine verricht.  
Verwijder of open de bak niet vooraleer U de motor hebt stopgezet

Sluit de inlaatopening of monteer het tussenstuk en de aanzuigtube en sluit de in-nen bak voor het gebruik.

Avant d'antamer le travail à la machine, retirez le câble d'allumage.  
Ne retirez ou n'ouvrez pas le sac avant l'immobilisation du moteur.  
Fermez l'ouverture d'admission ou montez une pièce de raccordement et un tube d'aspiration. Avant utilisation, fixez le sac à l'éjection.



5



Attrezzo in movimento. L'attrezzo continua a rotare dopo che il motore viene spento.

Umlaufendes Werkzeug. Werkzeug läuft nach!

Tool in motion. Tool continues to rotate after engine is switched off!

Outil de travail en mouvement. L'outil de travail continue de tourner après que le moteur été coupé.

Het werktuig blijft roteren nadat de motor werd afgezet.

6



7

REF. N°	PART. N°	QTY	DESCRIZIONE	DESCRIPTION	DESCRIPTION	BESCHREIBUNG
1			MOTORE	ENGINE	MOTEUR	MOTOR
2	P020684102VE		STEGOLA INFERIORE	LOWER HANDLEBAR COMPL.	GUIDON INFÉRIEUR COMPL.	HOLMUNTERTEIL KOMP
3	P1050011	6	DADO	NUT	ÉCROU	MUTTER
4	P1010134	2	VITE	SCREW	VIS	SCHRAUBE
5	P020300102ZN		ASSALE POSTERIORE	REAR AXLE	ESSIEU ARRIÈRE	HINTERACHSE
6	P1010119	4	VITE	SCREW	VIS	SCHRAUBE
7	P1010110	4	VITE	SCREW	VIS	SCHRAUBE
8	P1020050	2	RONDELLA	SPRING WASHER	RONDELLE ÉLASTIQUE	FEDERSCHEIBE
9	P2020088	2	DISTANZIALE	SPACER	RONDELLE	DISTANZBÜCHSE
10	P00015003	2	RUOTA	WHEEL	ROUE	RAD
11	P3030013	4	CUSCINETTO	BEARING	PALIER	LAGER
12	1020007A1		RONDELLA	WASHER	RONDELLE	SCHIBE
13	1010018A1	2	VITE	SCREW	VIS	SCHRAUBE
14	P2020333	2	COPRIMOZZO POST.	REAR COVER	COUVERCLE ARRIÈRE	DECKEL
15	P2020334	2	COPRIMOZZO ANT.	FRONT COVER	COUVERCLE ANTÉRIEUR	DECKEL
16	1010018A1	2	VITE	SCREW	VIS	SCHRAUBE
17	1020007A1	2	RONDELLA	WASHER	RONDELLE	SCHIBE
18	P3030013	4	CUSCINETTO	BEARING	PALIER	LAGER
19	P2020200	2	RUOTA	WHEEL	ROUE	RAD
20	P1020083	4	MOLLA	SPRING	RESSORT	FEDER
21	P1010120	2	VITE	SCREW	VIS	SCHRAUBE
22	1020014A1	2	RONDELLA	WASHER	RONDELLE	SCHIBE
23	P4020131	2	PORTA RUOTA	PIVOT ARM	SUPPORT	TRÄGER
24	P2020077	2	POMELLO LEVA	KNOB	POIGNÉE	ABDECKUNG
25	P1020064	4	RIVETTO	RIVET	RIVET	NIET
26	P4010139	2	LEVA ALZARUOTA	LEVER	LEVIER	HEBEL
27	P3040251	2	BUSSOLA	BUSHING	DOUILLE	BÜCHSE
28	P4010132	2	PIASTRA REG. TAGLIO	PLATE	PLAQUE	BLECH
29	P1010172	8	VITE	SCREW	VIS	SCHRAUBE
30	P1020088	20	RONDELLA	WASHER	RONDELLE	SCHIBE
31	P4010166ZN	2	PIASTRA RINFORZO	REINFORCEMENT PLATE	PLAQUE DE RENFORCEMENT	VERSTÄRKUNGSPLATTE
32	P1050011	6	DADO	NUT	ÉCROU	MUTTER
33	1050002A1	13	DADO	NUT	ÉCROU	MUTTER
34	P4010167ZN		PIASTRINA	PLATE	PLAQUE	PLATTE
35	P4010185ZT		PIASTRINA	PLATE	PLAQUE	PLATTE
36	P4010168ZN		PIASTRINA	PLATE	PLAQUE	PLATTE
37	P4010169ZN		LAMIERA RINFORZO	REINFORCEMENT PLATE	PLAQUE DE RENFORCEMEN	VERSTÄRKUNGSPLATTE
38	P1010170		VITE	SCREW	VIS	SCHRAUBE
39	P1020067		RONDELLA	WASHER	RONDELLE	SCHIBE
40	P0010170102BI		VENTOLA	FAN	SOUFFLERIE	GEBLÄSE
41	P1010092	2	VITE	SCREW	VIS	SCHRAUBE
42	P1010175	1	VITE	SCREW	VIS	SCHRAUBE
43	P4010193ZN	1	ANELLO RINFORZO	REINFORCEMENT RING	ANNEAU DE RENFORCEMENT	VERSTÄRKUNGSRING
44	P2020197	1	COPERCHIO SCOCCA	ADDITIONAL PLUG	FICHE ADDITIONNELLE	STOPFEN
45	P2020201	1	POMELLO	KNOB	POIGNÉE	MUTTER
46	P000050102	1	SCOCCA	DECK	CHÂSSIS	GEHÄUSE
47	P1020064	3	RIVETTO	RIVET	RIVET	NIET
48	P4030017VE	1	CONVOGLIATORE	CONVEYOR	CONVOYEUR	FÖRDERER
49	1090001A1	1	CHIAVE WOODRUFF	KEY	CLAVETTE	SCHIBENFEDER
50	P1020080	3	RONDELLA	WASHER	RONDELLE	SCHIBE
51	P1050011	3	DADO	NUT	ÉCROU	MUTTER
52	P2020165	1	CAPOTTINA MOTORE	ENGINE COVER	COUVERCLE MOTEUR	MOTORABDECKUNG
53	P1010154	2	VITE	SCREW	VIS	SCHRAUBE
54	P1010174	5	VITE	SCREW	VIS	SCHRAUBE
55	P3160044	1	SACCO RACCOGLITORE	COLLECTION BAG	SAC DE RAMASSAGE	FANGSACK
56	P000151102	2	RUOTA ANTER. COMPL.	WHEEL ASS. Y	ROUE COMPL.	RAD KOMP.
57	P000152102	2	RUOTA POSTER. COMPL.	WHEEL ASS. Y	ROUE COMPL.	RAD KOMP.
*	IB-2015		KIT SACCO ANTIPOLVERE	NO-DUST BAG	SAC ANTIPOUSSIERE	STAUBDICHTER SACK

Vista stegola superiore e comandi

Upper handle and controls

Mancheron partie supérieur et éléments de commande

Lenkeroberteil und Bedienungselemente

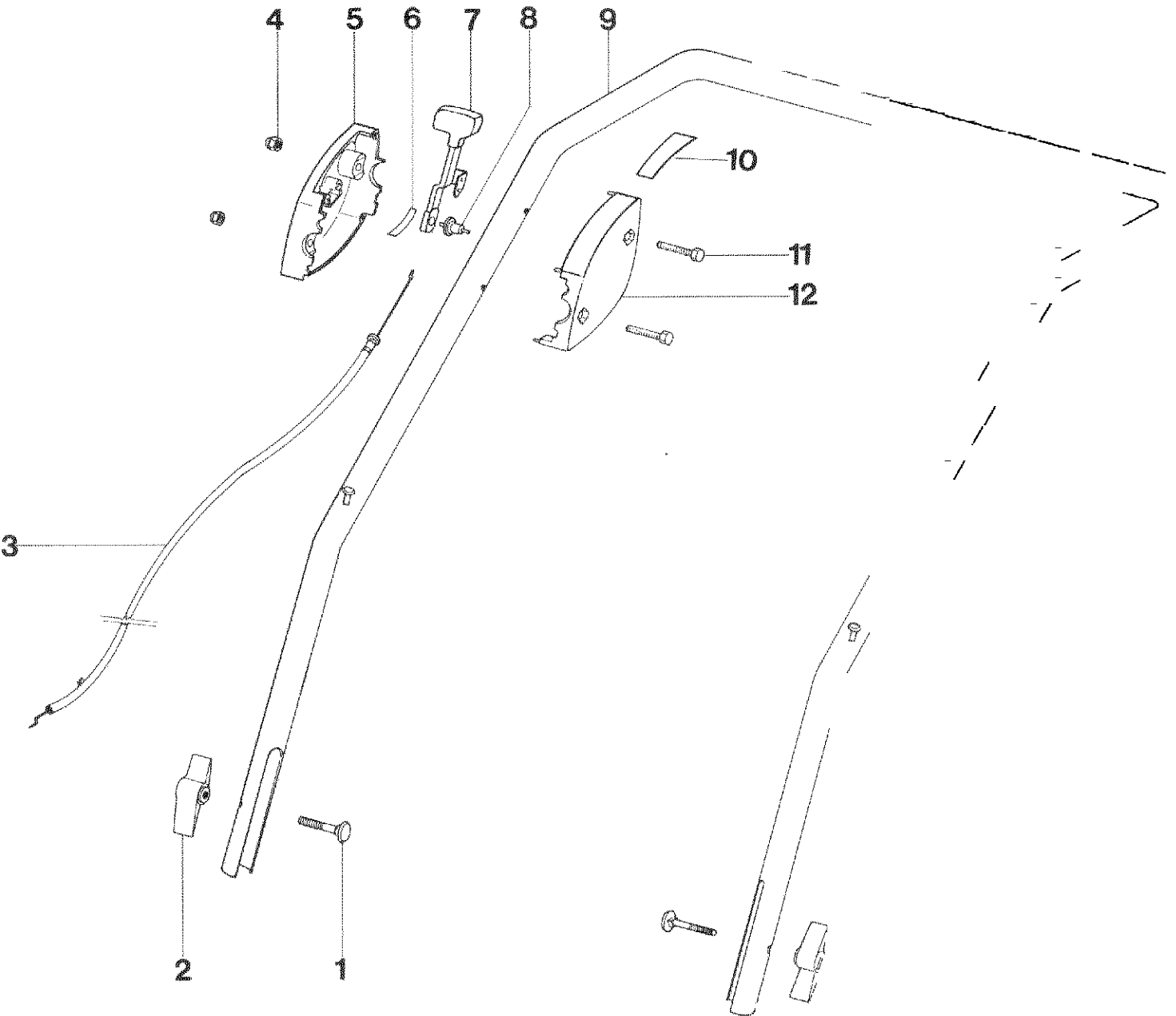

REF. N°	PART. N°	QTY	DESCRIZIONE	DESCRIPTION	DESCRIPTION	BESCHREIBUNG
1	1010026A1	2	VITE	SCREW	VIS	SCHRAUBE
2	2020050A1	2	POMELLO	KNOB	POIGNÉE	MUTTER
3	P5020055	1	CAVO ACCELERATORE	THROTTLE CABLE	CÂBLE DE GAZ	GASHEBEL
4	1050003A1	2	DADO	NUT	ÉCROU	MUTTER
5	P2020106	1	SCATOLA ACCELER. DX	R.H. HOUSING	BOÎTE DROITE	SCHALE R.
6	P4010059	2	MOLLA	SPRING	RESSORT	FEDER
7	P00065099	1	LEVA ACCELERATORE	THROTTLE LEVER	LEVIER DE GAZ	GASHEBEL
8	P2020108	1	NOTTOLINO	BOLT	BOULON	STIFT
9	P3120073VE	1	STEGOLA SUP.	UPPER HANDLEBAR	GUIDON SUP.	OB. FÜHRUNGSHOLM
10	P5140583	1	DECALCO	DECAL	MARQUAGE	AUFKLEBER
11	P1010102	2	VITE	SCREW	VIS	SCHRAUBE
12	P2020107	1	SCATOLA ACC. SX	L.H. HOUSING	BOÎTE GAUCHE	SCHALE L.

Kit aspirazione IB-2010  
 Vacuum kit IB-2010  
 Vacuum kit IB-2010  
 Saug-ausstattung IB-2010

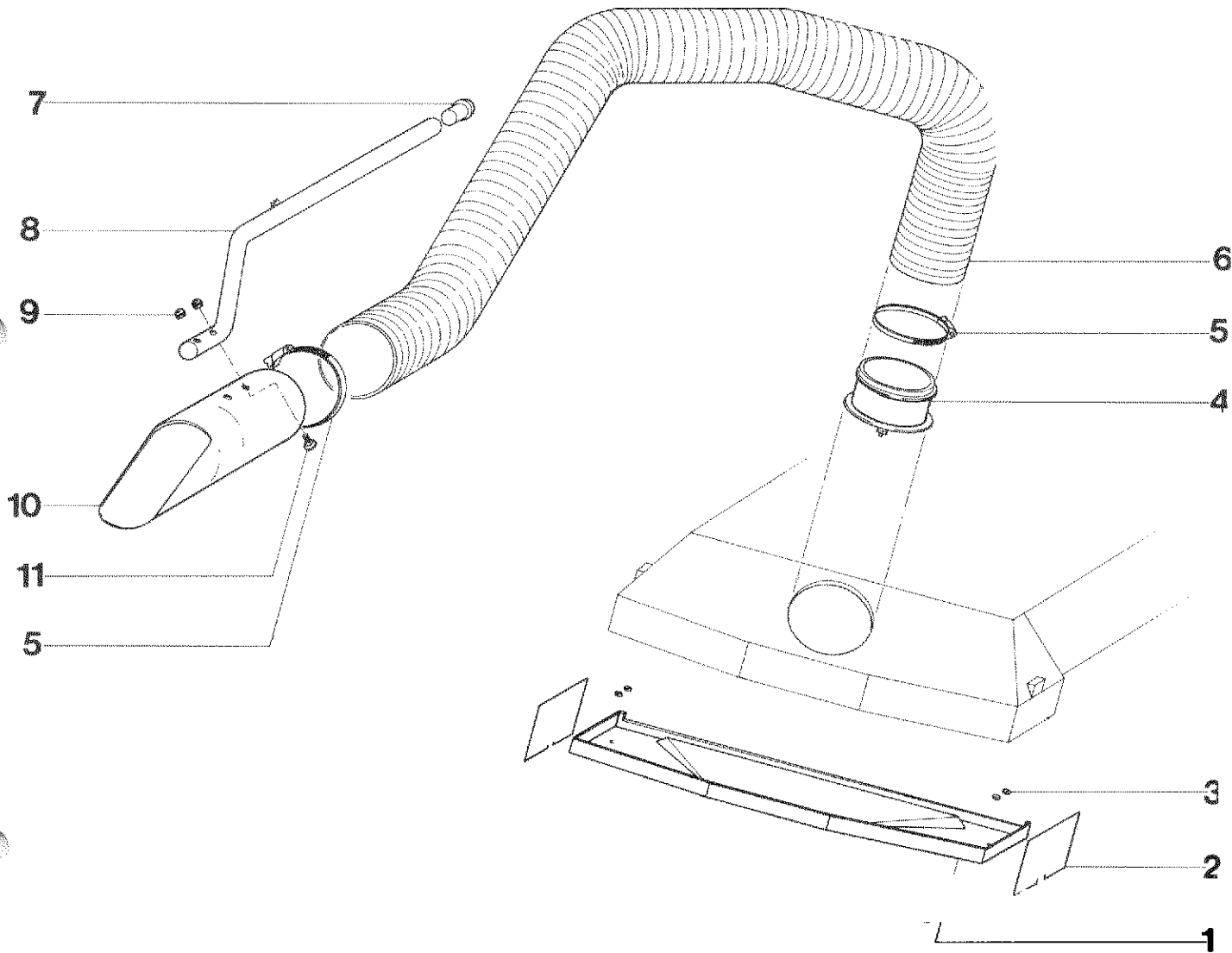

REF. N°	PART. N°	QTY	DESCRIZIONE	DESCRIPTION	DESCRIPTION	BESCHREIBUNG
1	P2020208	1	CARTER CHIUSURA	FUNNEL HOUSING	COUVERCLE EMBOUT	TRICHTERGEHÄUSE
2	P3020029	2	MOLLA	SPRING	RESSORT	FEDER
3	P1060013	4	STARLOCK	STARLOCK	STARLOCK	STARLOCK
4	P2020196	1	ATTACCO RAPIDO	COUPLING	COUPLAGE	ANSCHLUSSTEIL
5	P5040004	2	FASCETTA	CLAMP	CLIP	HALTER
6	P2020209	1	TUBO ASPIRAZIONE	INTAKE HOSE	TUYAU D'ASPIRATION	SAUGSCHLAUCH
7	P2020137	1	TAPPO	PLUG	BOUCHON	STÖPSEL
8	P3120074VE	1	MANICO BOCCHETTONE	HANDLE	MANCHON	HOLM
9	P1050007	2	DADO	NUT	ÉCROU	MÜTTER
10	P2020210	1	BOCCHETTONE ASPIR.	FUNNEL	EMBOUT	SAUGDÜSE
11	P1010078	2	VITE	SCREW	VIS	SCHRAUBE

Vista generale  
Complete machine  
Vue d'ensemble  
Gesamtansicht

