

IBEA

Modello n.	Serie dal n.
IB-4721F	001
IB-4727F	001
IB-4728F	001
IB-4742F	001

Stampato n. P5090156

LISTA RICAMBI

SPARE PART LIST

ERSATZTEILLISTE

LISTE DES PIECES DE RECHANGE



SERIE 470

REF. N°	PART. N°	QTY	DESCRIZIONE	DESCRIPTION	DESCRIPTION	BESCHREIBUNG
1	P5140532	1	DECALCO	DECAL	MARQUAGE	AUFKLEBER
2	P5140334	1	DECALCO	DECAL	MARQUAGE	AUFKLEBER
3	P5140537	1	DECALCO	DECAL	MARQUAGE	AUFKLEBER
4	P5140337	1	DECALCO	DECAL	MARQUAGE	AUFKLEBER
5	P5140545	1	DECALCO	DECAL	MARQUAGE	AUFKLEBER
6	P5140549	1	DECALCO	DECAL	MARQUAGE	AUFKLEBER
7	P5140531	1	DECALCO	DECAL	MARQUAGE	AUFKLEBER
8	P5140547	1	DECALCO	DECAL	MARQUAGE	AUFKLEBER
9	P5140534	1	DECALCO	DECAL	MARQUAGE	AUFKLEBER
10	P5140573	1	DECALCO	DECAL	MARQUAGE	AUFKLEBER
*	P5110008	1	CHIAVE TUBO	KEY	CLEF	SCHLÜSSEL
*	P5090159	1	MANUALE ISTRUZIONI	INSTRUCTION MANUAL	MODE D'EMPLOI	BEDIENUNGSANLEITUNG

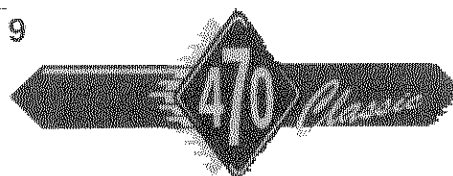
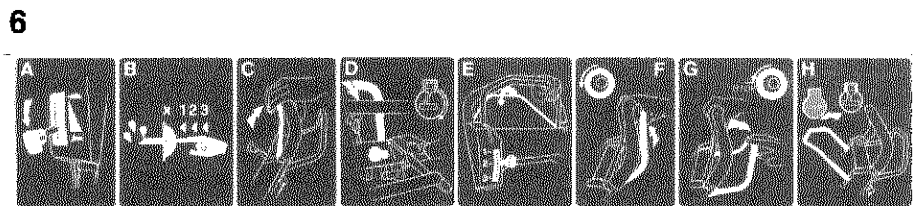
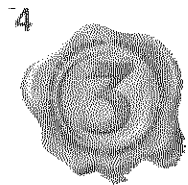
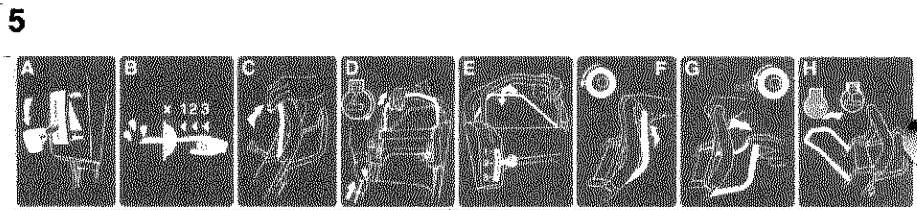
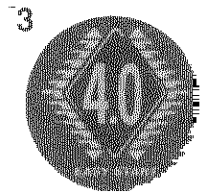
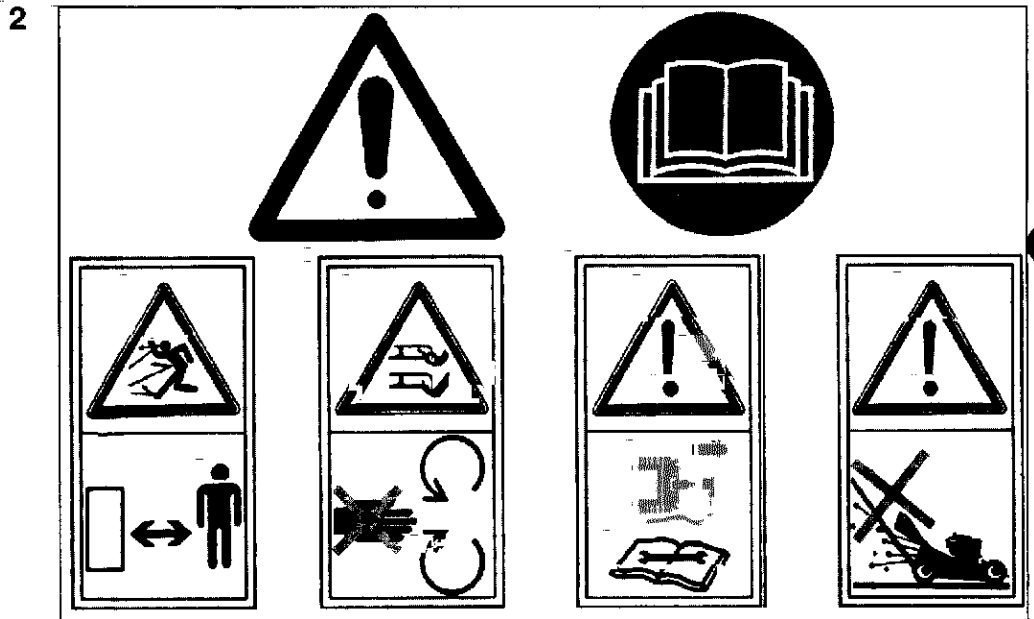

REF. N°	PART. N°	QTY	DESCRIZIONE	DESCRIPTION	DESCRIPTION	BESCHREIBUNG
		1	MOTORE	ENGINE	MOTEUR	MOTOR
2	P1050011	3	DADO	NUT	ECROU	MUTTER
3	1090001A1	1	CHIAVETTA	KEY	CLAVETTE	SCHEIBENFEDER
4	P1010071	1	VITE	SCREW	VIS	SCHRAUBE
5	P1010070	2	VITE	SCREW	VIS	SCHRAUBE
6	P2020051	1	CARTER COPRICINGHIA	BELT COVER	COUVERCLE	DECKEL
7	1020014A1	2	RONDELLA	WASHER	RONDELLE	SCHEIBE
8	2020050A1	2	POMELLO	KNOB	POIGNÉE	MUTTER
9	P1010154	2	VITE	SCREW	VIS	SCHRAUBE
10	P2020165	1	CAPOTTINA	ENGINE COVER	COUVERCLE MOTEUR	MOTORABDECKUNG
11	P1010153	2	VITE	SCREW	VIS	SCHRAUBE
12	P3020011	1	MOLLA	SPRING	RESSORT	FEDER
13	P2020058	1	PORTELLO	SHIELD	PROTECTION	KLAPPE
14	P3050051VE	1	SUPPORTO	HANDLEBAR SUPPORT	SUPPORT DE GUIDON	HOLMHALTER
15	P1050011	2	DADO	NUT	ÉCROU	MUTTER
16	P1060004	2	FISSATORE	WASHER	RONDELLE	SCHEIBE
17	P01027080	1	ASTINA	SHAFT	ARBRE	ACHSE
18	P1010161	1	VITE	SCREW	VIS	SCHRAUBE
19	1020014A1	1	RONDELLA	WASHER	RONDELLE	SCHEIBE
20	P2020053	1	CARTER	COVER	COUVERCLE	DECKEL
21	P4080016	2	SUPPORTO ASSALE	AXLE SUPPORT	SUPPORT ESSIEU	HALTER
22	1060002A1	2	ANELLO	NUT	ÉCROU	MUTTER
23	P4010215VE	1	ASTA	ROD	TIGE	STANGE
24	3040010A1	2	BULLONE	BOLT	BOULON	STIFT
25	P1010073	4	VITE	SCREW	VIS	SCHRAUBE
26	1020014A1	3	RONDELLA	WASHER	RONDELLE	SCHEIBE
27	P1010098	1	VITE	SCREW (B&S)	VIS (B&S)	SCHRAUBE (B&S)
28	P1010097	2	VITE	SCREW (B&S)	VIS (B&S)	SCHRAUBE (B&S)
28	P1010135	3	VITE	SCREW (TECNA)	VIS (TECNA)	SCHRAUBE (TECNA)
29	P4090005VEE	1	SCOCCA	MOWERDECK	CHÂSSIS	GEHAUSE
30	P1030005	1	BUSSOLA	BUSHING	DOUILLE	BÜCHSE
31	1020010A1	1	RONDELLA	WASHER	RONDELLE	SCHEIBE
32	P1070007	1	SEEGER	CIRCLIP	SEEGER	SEEGER
33	P2020055	1	CHIOCCIOLA	NUT	ÉCROU	MUTTER
34	1020007A1	1	RONDELLA	WASHER	RONDELLE	SCHEIBE
35	P1010018	1	VITE	SCREW	VIS	SCHRAUBE
36	P3050044	1	MANIGLIA ALZARUOTA	HEIGHT ADJ. LEVER	LEVIER RÉG. HAUT. DE COUPE	HEBEL FÜR SCHNITTHÖHENVERSTEL.
37	P3020030	1	MOLLA	SPRING	RESSORT	FEDER
38	P1020093	1	RONDELLA	SPACER	ÉPAISSEUR	SCHEIBE
39	P00030380	1	ASSALE ANTERIORE	FRONT AXLE	ESSIEU AVANT	VORDERACHSE
40	P4080015	2	SUPPORT ASSALE	AXLE SUPPORT	SUPPORT ESSIEU	HALTER
41	P1010073	4	VITE	SCREW	VIS	SCHRAUBE
42	P3040102	1	BUSSOLA LAMA. A TRAZ.	BLADE BUSHING, SELF-PROP.	DOUILLE DE LAME., TRACTÉ	MESSERBÜCHSE, MOD. MIT RADAN.
42	P3040254	1	BUSSOLA LAMA. A SPINTA.	BLADE BUSHING, PUSH MOD.	DOUILLE DE LAME, POUSSÉ	MESSERBÜCHSE, HANDGEST. MOD.
43	P4050018	1	LAMA TOSAERBA	BLADE	LAME	MESSER
44	1110002A1	1	MOLLA	SPRING	RESSORT	FEDER
45	P1010050	1	VITE LAMA	BLADE SCREW	VIS DE COUTEAU	MESSERSCHRAUBE
46	P1020067	1	RONDELLA	WASHER	RONDELLE	SCHEIBE
47	P1020050	2	RONDELLA	SPRING WASHER	RONDELLE ÉLASTIQUE	FEDERSCHEIBE
48	P2020088	2	DISTANZIALE	SPACER	RONDELLE	DISTANZBÜCHSE
49	P2020377	2	COPRIRUOTA	WHEEL COVER	COUVERCLE DE ROUE	RADABDECKUNG
50	P3030013	4	CUSCINETTO	BEARING	PALIER	LAGER
51	P2020079	2	CERCHIO	RIM	FRETTE	FELGE
51	P2020378	2	CERCHIONE	HUB	JANTE	FELGE
52	P2020078	2	COPERTONE	TYRE	PNEU	REIFEN
53	1020007A1	2	RONDELLA	WASHER	RONDELLE	SCHEIBE
54	1010018A1	2	VITE	SCREW	VIS	SCHRAUBE
55	P2080002	2	RUOTA	WHEEL ASS.Y	ROUE COMPL.	RAD KOMP.
56	P2020062	2	COPRIMOZZO	COVER	COUVERCLE	DECKEL
57		2	VEDI TAV. 3	SEE TAV. 3	VOIR TAV. 3	SIEHE TAV. 3
58	P1010125	1	VITE	SCREW	VIS	SCHRAUBE
59	P3050052VE	1	SUPPORTO	HANDLEBAR SUPPORT	SUPPORT DE GUIDON	HOLMHALTER
60	P3020014	1	MOLLA	SPRING	RESSORT	FEDER
61	P5050002	1	CAVO	CABLE	CÂBLE	KABEL
62	P2020148	1	DEFLETTORE	DEFLECTOR	DÉFLECTEUR	DEFLEKTOR
63	P2020104	1	SCIVOLO ERBA	GRASS CHUTE	DÉFLECTEUR À HERBE	DEFLEKTOR
64	P00011280	1	TELAIO CESTELLO	BAG FRAME	MONTURE	GESTELL
65	P3160032	1	SACCO	GRASS BAG	SAC DE RAMASSAGE	GRASFANGSACK
66	P00011180	1	CESTELLO COMPLETO	GRASS BAG ASS.Y	SAC DE RAMASSAGE COMPL	GRASFANGSACK KOMP.

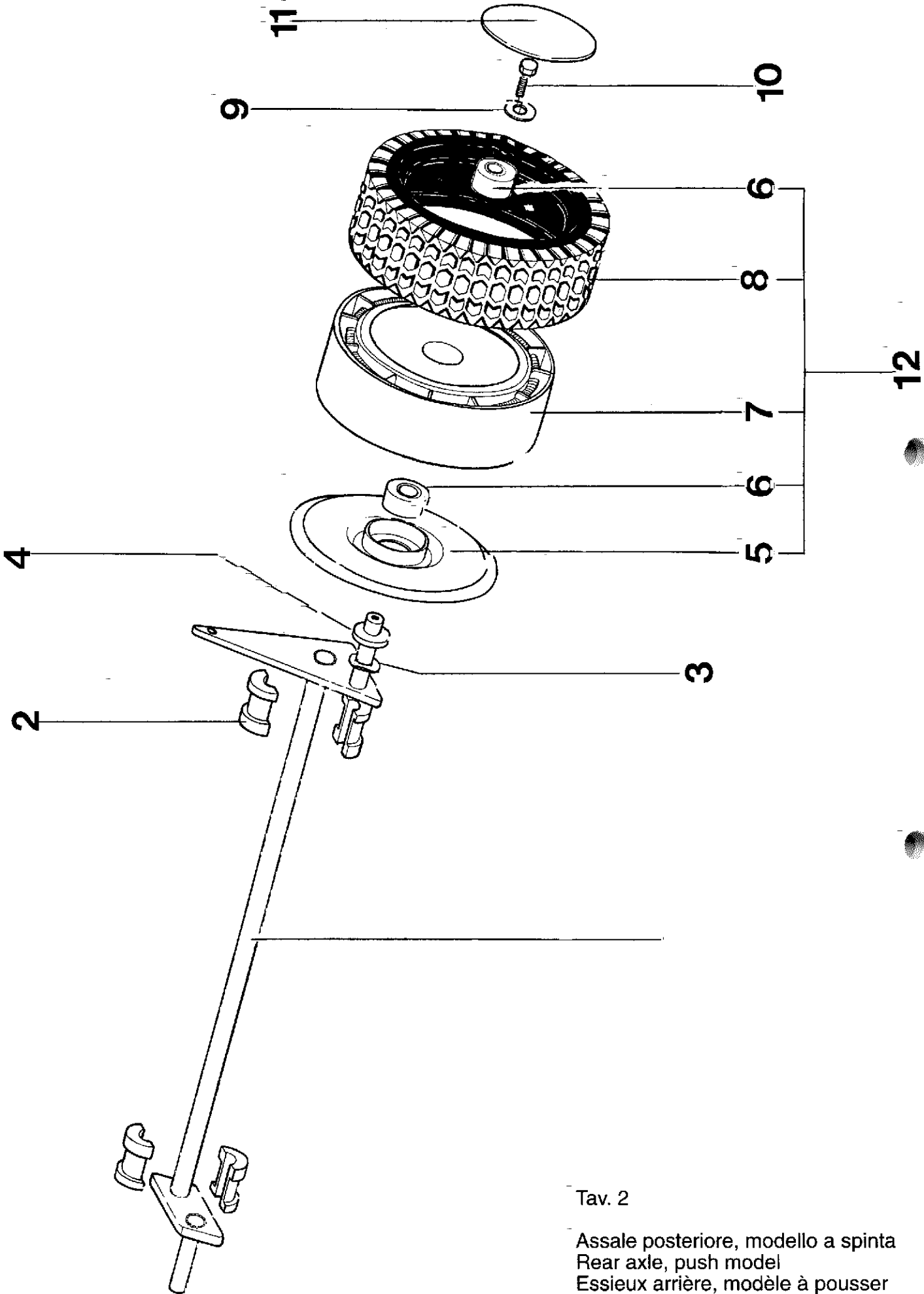

Tav. 2

Assale posteriore, modello a spinta
 Rear axle, push model
 Essieux arrière, modèle à pousser
 Hinterachse, handgestoßen Modell

REF. N°	PART. N°	QTY	DESCRIZIONE	DESCRIPTION	DESCRIPTION	BESCHREIBUNG
1	P3060041ZT	1	ASSALE POST.	REAR AXLE SHAFT	ESSIEU ARRIÈRE	HINTRACHSE
2	P2020056	4	SEMIBUSSOLA	HALF BUSHING	SEMI DOUILLE	GETEILTE BÜCHSE
3	P1020050	2	RONDELLA	SPRING WASHER	RONDELLE ÉLASTIQUE	FEDERSCHEIBE
4	P2020088	2	DISTANZIALE	SPACER	RONDELLE	DISTANZBÜCHSE
5	P2020128	2	COPRIRUOTA	WHEEL COVER	PROTECTION	ABDECKUNG
6	P3030013	4	CUSCINETTO	BEARING	PALIER	LAGER
7	P2020082	2	CERCHIO	FRONT HUB	JANTE ANT.	FELGE
8	P2020083	2	COPERTONE	TYRE	PNEU	REIFEN
9	1020007A1	2	RONDELLA	WASHER	RONDELLE	SCHEIBE
10	1010018A1	2	VITE	SCREW	VIS	SCHRAUBE
11	P1020050	2	RONDELLA	SPRING WASHER	RONDELLE ÉLASTIQUE	FEDERSCHEIBE
12	P00015176	2	RUOTA COMPLETA	WHEEL ASS.Y	ROUE COMPL.	RAD KOMP.

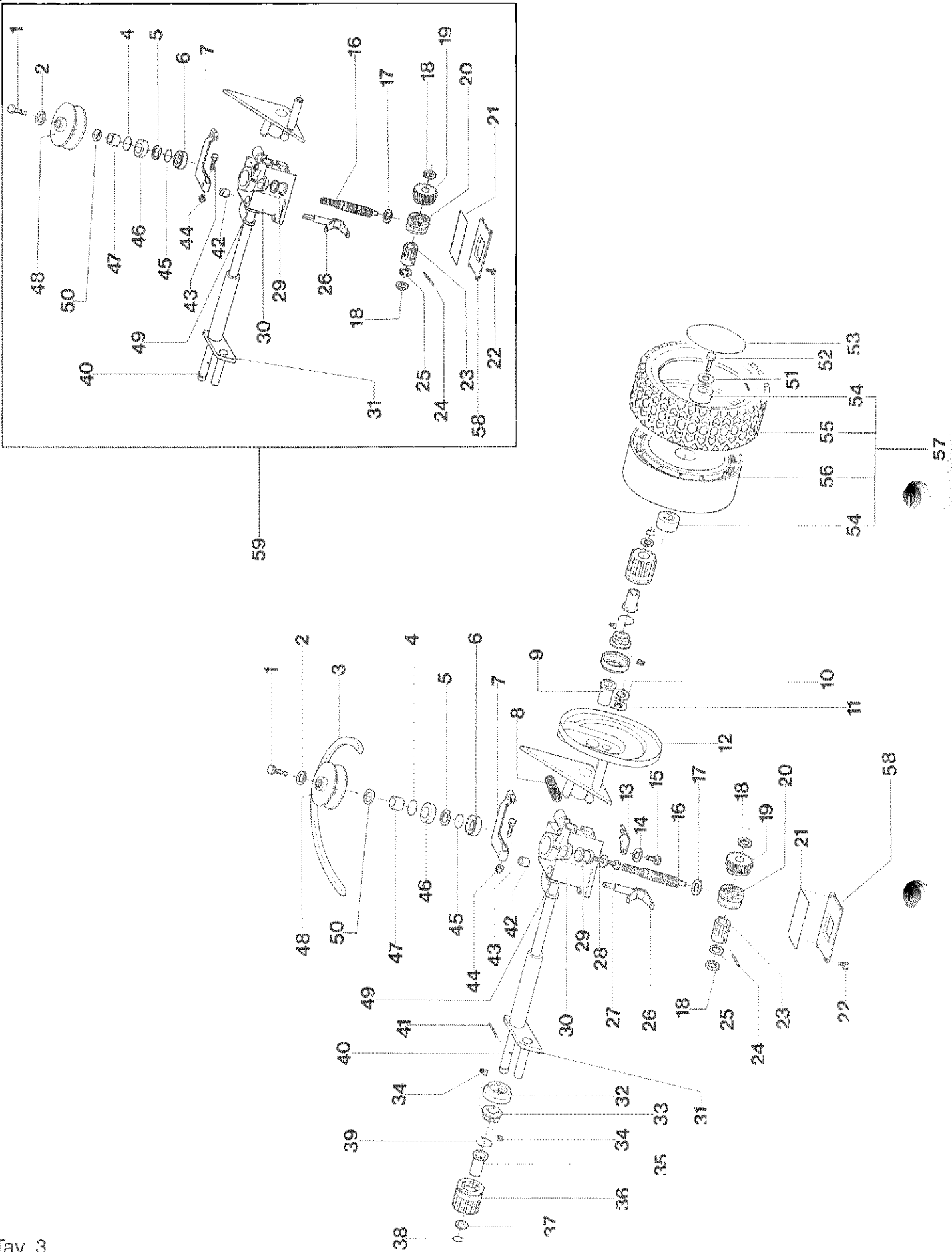

Tav. 3

Assale posteriore e trasmissione, modello a trazione
 Rear axle and gear box, self-propelled model
 Essieux arrière et transmission, modèle tracté
 Hinterachse und Getriebe, Modell mit Radantrieb

REF. N°	PART. N°	QTY	DESCRIZIONE	DESCRIPTION	DESCRIPTION	BESCHREIBUNG
	1010018A1		VITE	SCREW	VIS	SCHRAUBE
2	1020007A1		RONDELLA	WASHER	RONDELLE	SCHEIBE
3	P3010027		CINGHIA	BELT	COURROIE	RIEMEN
4	P3170013		O-RING	SPACER	DOUILLE	ABSTANDSSTÜCK
5	P1020051		RONDELLA	WASHER	RONDELLE	SCHEIBE
6	P3030010		CUSCINETTO	BEARING	PALIER	LAGER
7	P4070011		LEVA TRAZIONE	LEVER	LEVIER	HEBEL
8	P3020010	1	MOLLA	SPRING	RESSORT	FEDER
9	P2020070	2	BOCCOLA	BUSHING	DOUILLE	BÜCHSE
10	P2020088	2	DISTANZIALE	SPACER	RONDELLE	DISTANZBÜCHSE
11	P1020050	2	RONDELLA	SPRING WASHER	RONDELLE ÉLASTIQUE	FEDERSCHEIBE
12	P4030011	2	COPRIRUOTA	WHEEL COVER	PROTECTION	ABDECKUNG
13	P4030010		COPERCHIETTO	COVER	COUVERCLE	DECKEL
14	P1020055		RONDELLA	WASHER	RONDELLE	SCHEIBE
15	P1010076	1	VITE	SCREW	VIS	SCHRAUBE
16	P3040042	1	VITE SENZA FINE	WORM GEAR	VIS SANS FIN	SCHNECKE
17	P1020053	1	RONDELLA	SPACER	DOUILLE	ABSTANDSSTÜCK
18	1020020A1	2	RONDELLA	WASHER	RONDELLE	SCHEIBE
19	P00038199	1	RUOTA ELICOIDALE	WORM WHEEL	ROUE POUR VIS S. FIN	SCHNECKENRAD
20	P00038099	1	INNESTO	SELECTOR COLLAR	MANCHON	SCHALTBÜCHSE
21	P3170014	1	O-RING	O-RING	JOINT TORIQUE	GUMMIRING
22	P1010076	1	VITE	SCREW	VIS	SCHRAUBE
23	P3050030	1	BUSSOLA	BUSHING	DOUILLE CANNELÉE	KELHÜLSE
24	P1080007	1	SPINA	PIN	GOUPILLE	STIFT
25	P1020051	1	RONDELLA	WASHER	RONDELLE	SCHEIBE
26	P3040041	1	FORCELLA	FORK	FOURCHE	GABEL
27	P1010073	1	VITE	SCREW	VIS	SCHRAUBE
28	P1020054	1	RONDELLA	WASHER	RONDELLE	SCHEIBE
29	P2040010	1	ANTIVIBRANTE	RUBBER TUBE	TUBE DE PROTECTION	SCHUTZHÜLLE
30	P00039199	1	SCATOLA RIDUTTORE	GEARBOX HOUSING	BOÎTE DE VITESSE	GETRIEBE
31	P3060040ZT	1	ASSALE POST.	REAR AXLE SHAFT	ESSIEU ARRIÈRE	HINTERACHSE
32	P2020060	2	COPRIPIGNONE	CAGE	CAGE	KÄFIG
33	P2100001	2	CAMME	CAMME DRIVER	CLIQUETTE DE CAMME	MITNEHMER
34	P2110001	4	SALTERELLO	KEY	CLAVETTE	SCHEIBENFEDER
35	P2020059	2	BUSSOLA	BUSHING	DOUILLE	BÜCHSE
36	P3050031	2	RUOTA DENTATA	PINION	PIGNON	RITZEL
37	1020020A1	2	RONDELLA	WASHER	RONDELLE	SCHEIBE
38	1070001A1	2	SEEGER	CIRCLIP	SEEGER	SEEGER
39	P3020012	2	MOLLA	SPRING	RESSORT	FEDER
40	P3040047		ALBERO TRAZIONE	TRACTION SHAFT	ARBRE DE TRACTION	ANTRIEBSWELLE
41	P1080004	2	SPINA	PIN	GOUPILLE	STIFT
42	P3170012	1	ANELLO DI TENUTA	OIL SEAL	JOINT D'ARBRE	WELLENDICHTRING
43	P1010075	1	VITE	SCREW	VIS	SCHRAUBE
44	1050003A1	1	DADO	NUT	ÉCROU	MUTTER
45	P1070004	1	SEEGER	CIRCLIP	SEEGER	SEEGER
46	P3170010	1	ANELLO DI TENUTA	OIL SEAL	JOINT D'ARBRE	WELLENDICHTRING
47	P3040049	1	BUSSOLA	BUSHING	DOUILLE	BÜCHSE
48	P3040244	1	PULEGGIA	PULLEY	POULIE	RIEMENSCHLEIBE
49	P3170011	1	ANELLO DI TENUTA	OIL SEAL	JOINT D'ARBRE	WELLENDICHTRING
50	P1020104	1	SPESSORE	WASHER	RONDELLE	SCHEIBE
51	1020007A1	2	RONDELLA	WASHER	RONDELLE	SCHEIBE
52	1010018A1	2	VITE	SCREW	VIS	SCHRAUBE
53	P2020062	2	COPRIMOZZO	COVER	COUVERCLE	DECKEL
54	P3030013	4	CUSCINETTO	BEARING	PALIER	LAGER
55	P2020083	2	COPERTONE	TYRE	PNEU	REIFEN
56	P2020084	2	CERCHIO	REAR HUB	FRETTE ARRIÈRE	HINTERFELGE
57	P00015276	2	RUOTA	REAR WHEEL	ROUE ARRIÈRE	HINTERRAD
58	P4110001	1	COPERCHIO	COVER	COUVERCLE	DECKEL
59	P2090001	1	SCATOLA RIDUTT. COMPL.	GEAR BOX ASS.Y	TRANSMISSION COMPL.	FAHRGETRIEBE KOMP.

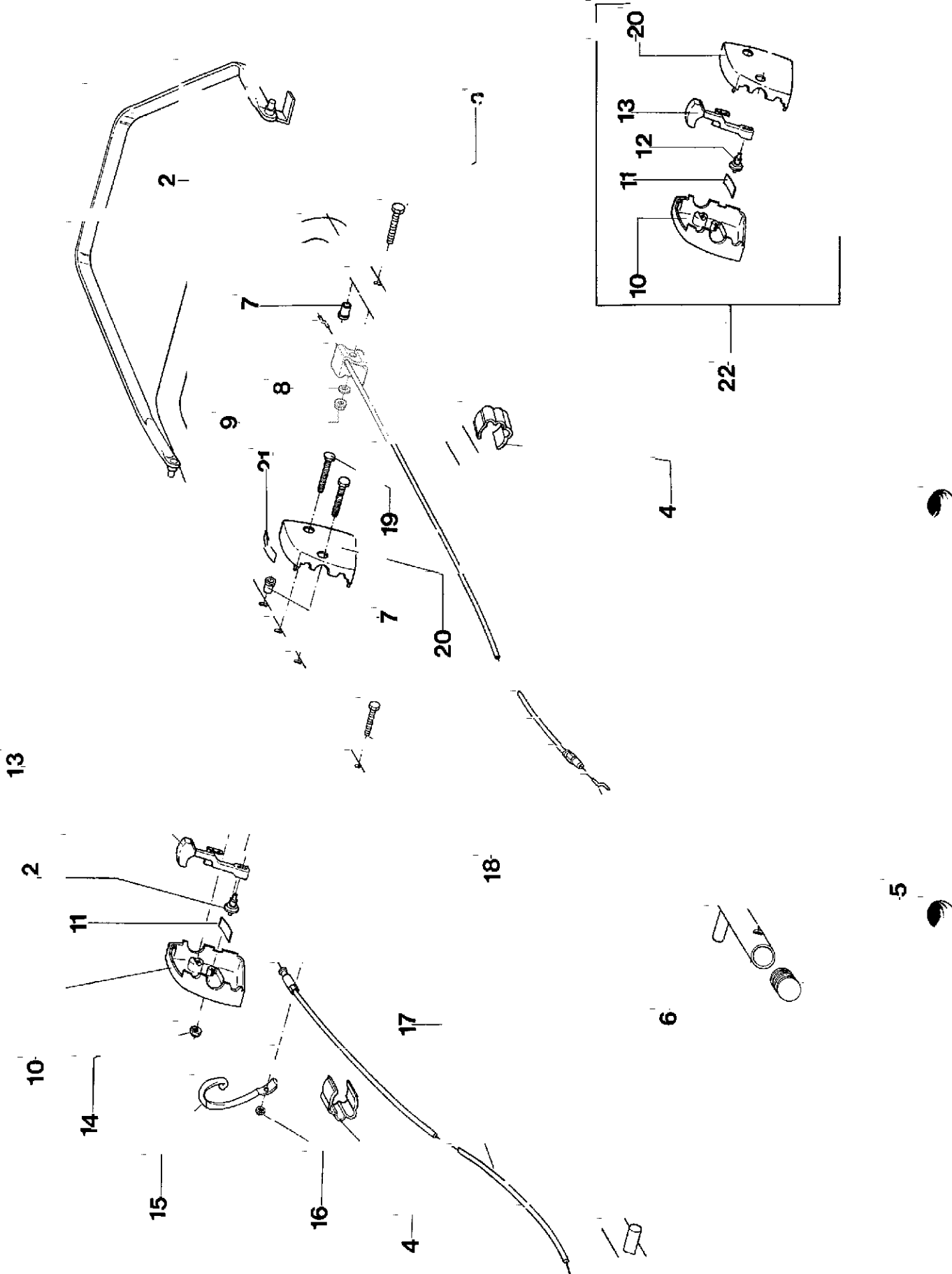

Tav. 4

Stegola superiore e comandi, modello a spinta

Upper handle and controls, push model

Guidon supérieur et éléments de commande, modèle à pousser

Lenkeroberteil und Bedienungselemente, handgestoßen Modell

REF. N°	PART. N°	QTY	DESCRIZIONE	DESCRIPTION	DESCRIPTION	BESCHREIBUNG
1	P4080037VE	1	MANIGLIA SYSTEM 2	SYSTEM 2 LEVER	LEVIER SYSTEM 2	SYSTEM 2 HEBEL
2	P3120100VE	1	STEGOLA	HANDLEBAR	GUIDON	FÜHRUNGSHOLM
3	P1010203	1	VITE	SCREW	VIS	SCHRAUBE
4	P2020080	2	FERMA CAVO	CLIP	CLIP	HALTER
5	P2020142	2	TAPPO	PLUG	BOUCHON	PFROPFEN
6	P5010056	1	CAVO	SYSTEM 2 CABLE	CÂBLE SYSTEM 2	SYSTEM 2 KABEL
7	P3040123	2	BUSSOLA	BUSHING	DOUILLE	BÜCHSE
8	1020013A1	1	RONDELLA	WASHER	RONDELLE	SCHEIBE
9	1050003A1	1	DADO	NUT	ÉCROU	MUTTER
10	P2020374	1	SCATOLA ACCELERATORE	THROTTLE HOUSING	BOÎTE DE GAZ	GASGEHÄUSE
11	P4010059	2	MOLLA	SPRING	RESSORT	FEDER
12	P2020108	1	NOTTOLINO	BOLT	BOULON	STIFT
13	P00065099	1	LEVA ACCELERATORE	THROTTLE LEVER	LEVIER DE COMMANDE	GASHEBEL
14	1050003A1	2	DADO	NUT	ÉCROU	MUTTER
15	P01068343	1	SUPPORTO A RICCIOLO	STARTER HOLDER	SUPPORT	HALTER
16	1050002A1	1	DADO	NUT	ÉCROU	MUTTER
17	P5020065	1	CAVO ACCELERATORE	THROTTLE CABLE	CÂBLE DE GAZ	GASKABEL
18	1010002A1	1	VITE	SCREW	VIS	SCHRAUBE
19	P1010102	2	VITE	SCREW	VIS	SCHRAUBE
20	P2020375	1	SCATOLA ACCELERATORE	THROTTLE HOUSING	BOÎTE DE GAZ	GASGEHÄUSE
21	P5140552	1	DECALCO ACCELER.	DECAL	MARQUAGE	AUFKLEBER
22	P3060052	1	SCATOLA ACC. COMPL.	THROTTLE HOUSING ASS.Y	BOÎTE DE GAS COMPL.	GASGEHÄUSE KOMP.

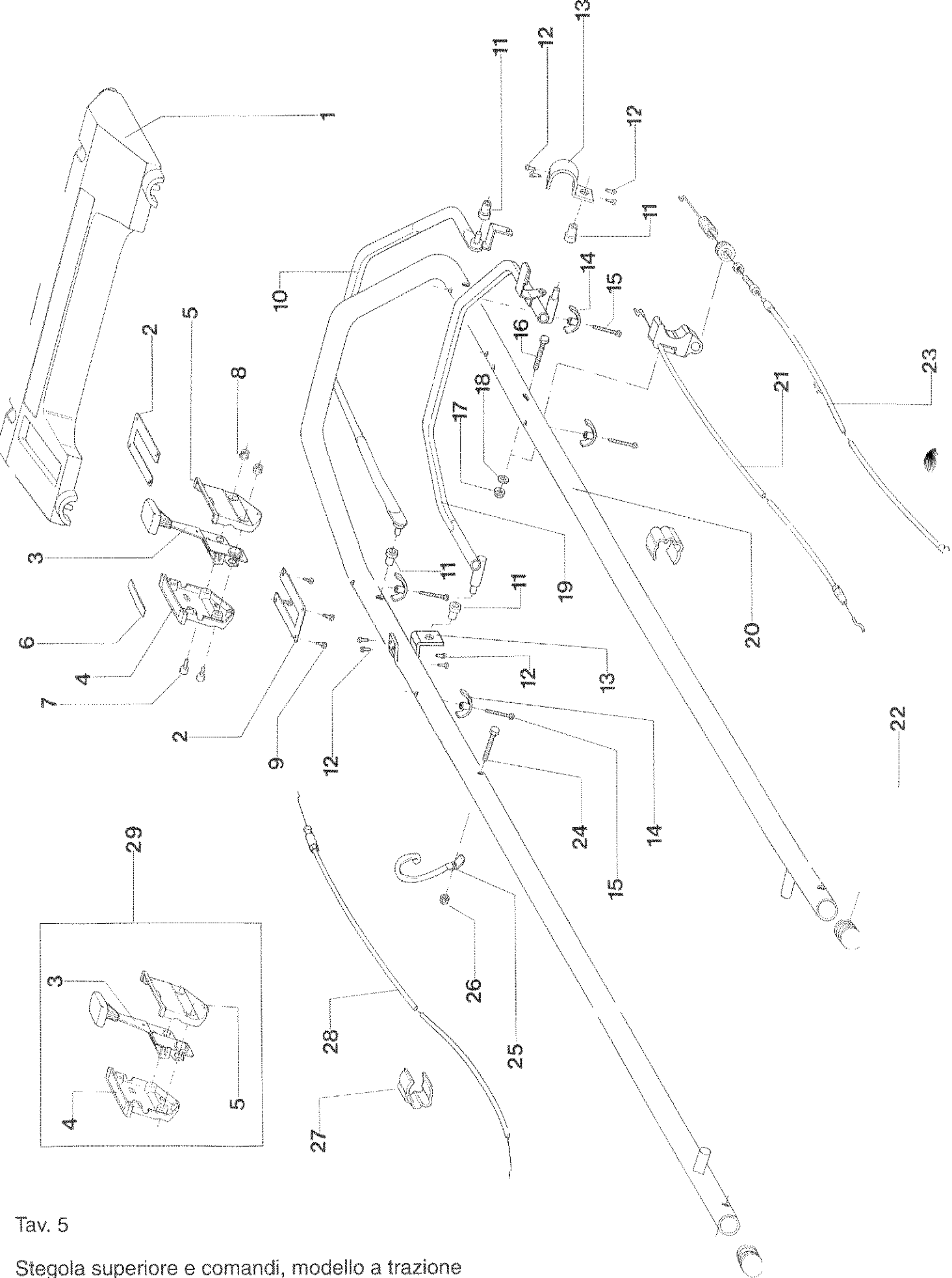

Tav. 5

Stegola superiore e comandi, modello a trazione
 Upper handle and controls, self-propelled model
 Guidon supérieur et éléments de commande, modèle tracté
 Lenkeroberteil und Bedienungselemente, Modell mit Radantrieb

REF. N°	PART. N°	QTY	DESCRIZIONE	DESCRIPTION	DESCRIPTION	BESCHREIBUNG
1	P2020367		PANNELLO DI CONTROL.	CONTROL PANEL	PANNEAU DE CONTRÔLE	SCHALTTAFEL
2	P4010217ZT	2	SOSTEGNO	SUPPORT	SUPPORT	HALTER
3	P3090006	1	LEVA ACCELERATORE	THROTTLE LEVER	LEVIER DE GAZ	GASHEBEL
4	P2020366	1	SEMISCATOLA COM. DX	HALF HOUSING, R.H.	SEMI-BOÎTE DROITE	HALBGEHÄUSE, R.
5	P2020365		SEMISCATOLA COM. SX	HALF HOUSING, L.H.	SEMI-BOÎTE GAUCHE	HALBGEHÄUSE, L.
6	P5140547	1	DECALCO	DECAL	MARQUAGE	AUFKLEBER
7	P1010207	2	VITE	SCREW	VIS	SCHRAUBE
8	1050002A1	2	DADO	NUT	ECROU	MUTTER
9	P1010205	4	VITE	SCREW	VIS	SCHRAUBE
10	P4080033VE	1	MANIGLIA TRAZIONE	TRACTION LEVER	LEVIER DE TRACTION	ANTRIEBSHEBEL
11	P3040123	4	BUSSOLA	BUSHING	DOUILLE	BÜCHSE
12	P1020106	8	RIVETTO	RIVET	RIVET	NIET
13	P4010222ZN	2	SUPPORTO	SUPPORT	SUPPORT	HALTER
14	P2020369	4	CAVALLOTTO	RETAINER	ARRÊT	HALTER
15	P1010204	4	VITE	SCREW	VIS	SCHRAUBE
16	P1010203		VITE	SCREW	VIS	SCHRAUBE
17	1050003A1	1	DADO	NUT	ECROU	MUTTER
18	1020013A1	1	RONDELLA	WASHER	RONDELLE	SCHEIBE
19	P4080034VE	1	MANIGLIA SYSTEM 2	SYSTEM 2 LEVER	LEVIER SYSTEM 2	SYSTEM 2 HEBEL
20	P3120093VE	1	STEGOLA	HANDLEBAR	GUIDON	FÜHRUNGSHOLM
21	P5010052	1	CAVO SYSTEM 2	SYSTEM 2 CABLE	CÂBLE SYSTEM 2	SYSTEM 2 KABEL
21	P5010065	1	CAVO SYSTEM 2 (4742F)	SYSTEM 2 CABLE (4742F)	CÂBLE SYSTEM 2 (4742F)	SYSTEM 2 KABEL (4742F)
22	P2020142	2	TAPPO	PLUG	BOUCHON	PFPÖFFEN
23	P5010058	1	CAVO TRAZIONE	TRACTION CABLE	CÂBLE DE TRACTION	ANTRIEBSKABEL
24	1010002A1	1	VITE	SCREW	VIS	SCHRAUBE
25	P01068343	1	SUPPORTO A RICCILO	STARTER HOLDER	SUPPORT	HALTER
26	1050002A1	1	DADO	NUT	ECROU	MUTTER
27	P2020080	2	FERMA CAVO	CLIP	CLIP	HALTER
28	P5020065	1	CAVO ACCELERATORE	THROTTLE CABLE	CÂBLE DE GAZ	GASKABEL
28	P5020072	1	CAVO ACCEL. (4742F)	THROTTLE CABLE (4742F)	CÂBLE DE GAZ (4742F)	GASKABEL (4742F)
29	P3080001		SCATOLA ACC. COMPL.	THROTTLE HOUSING ASS.Y	BOÎTE DE GAZ COMP.	GASGEHÄUSE KOMP.

Stegola superiore e comandi, modello a trazione, Electric Start
Upper handle and controls, self-propelled model, Electric Start
Guidon supérieur et éléments de commande, modèle tracté, Electric Start
Lenkeroberteil und Bedienungselemente, Modell mit Radantrieb, Electric Start

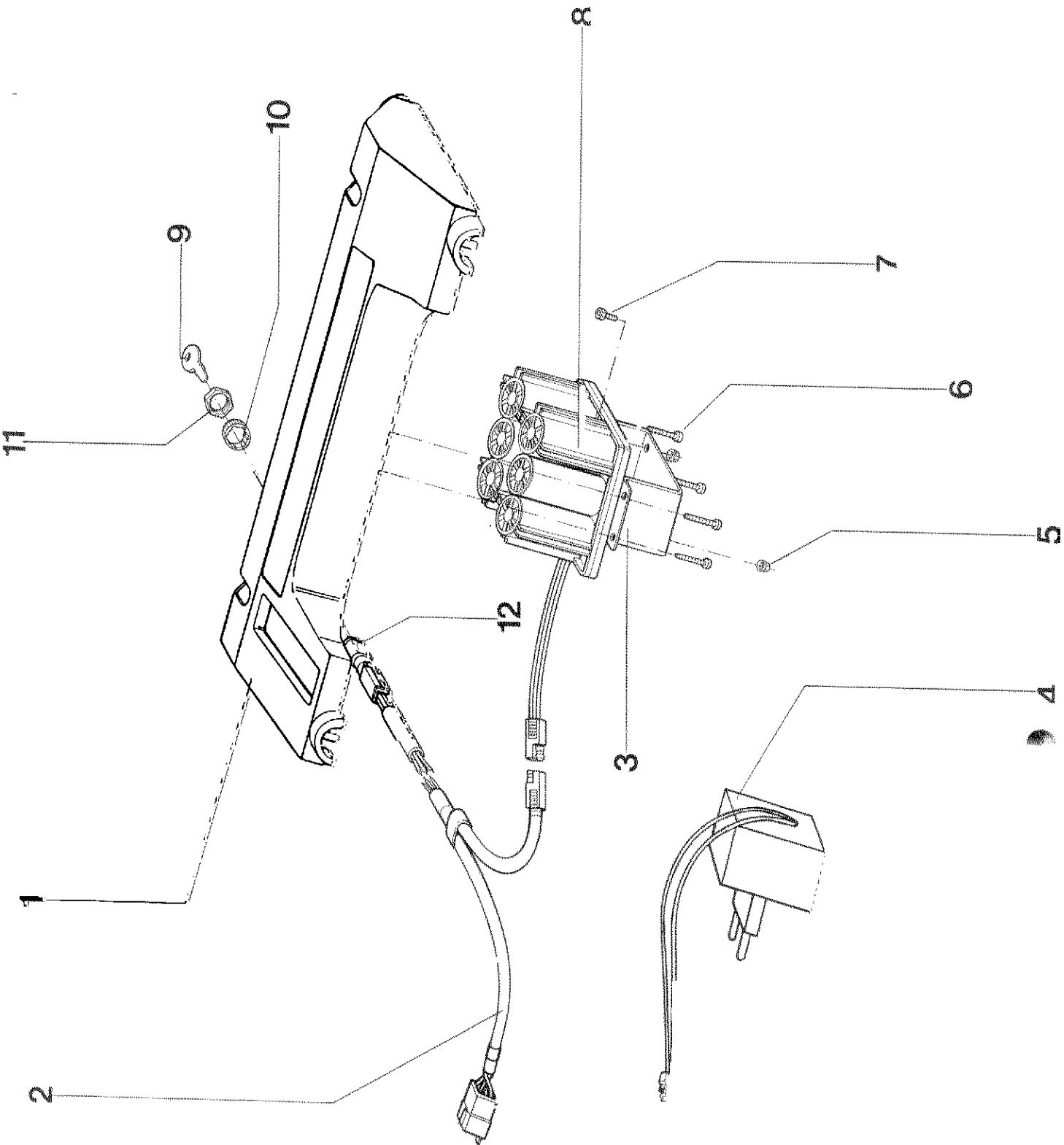

REF. N°	PART. N°	QTY	DESCRIZIONE	DESCRIPTION	DESCRIPTION	BESCHREIBUNG
1	P2020367	1	PANNELLO DI CONTROL.	CONTROL PANEL	PANNEAU DE CONTRÔLE	SCHALTTAFEL
2	P5030018	1	CAVO ELETTRICO	WIRE	CÂBLE ÉLECTRIQUE	KABEL
3	P4010225ZNT	1	STAFFA	SUPPORT	SUPPORT	HALTER
4	P5030009	1	CARICA BATTERIA	BATTERY CHARGER	CHARGEUR D'ACCUMULAT.	LADEGERÄT
5	1050002A1	2	DADO	NUT	ÉCROU	MUTTER
6	P1010209	4	VITE	SCREW	VIS	SCHRAUBE
7	P1010207	2	VITE	SCREW	VIS	SCHRAUBE
8	P5030008	1	BATTERIA 12V	BATTERY 12V	BATTERIE 12V	BATTERIE 12V
9	P5030011	2	CHIAVE X AVVIAM.	KEY	CLÉ DE CONTACT	SCHLÜSSEL
10		1	VEDI REF. 12	SEE REF. 12	VOIR REF. 12	SIHE REF. 12
11		1	VEDI REF. 12	SEE REF. 12	VOIR REF. 12	SIHE REF. 12
12	P5030010	1	BLOCCHETTO AVV. EL.	KEY SWITCH	INTERRUPTEUR	SCHLÜSSELSCHALTER

Vista generale
Complete machine
Vue d'ensemble
Gesamtansicht

