

# IBEA

**POWER PRODUCTS**

Modello n.	Serie dal n.
IB-4717F	960202
IB-4721F	960357
IB-4727F	961379
IB-4728F	960607
IB-4742F	149

Stampato n° P5090244

**LISTA RICAMBI**

**SPARE PARTS LIST**

**ERSATZTEILLISTE**

**LISTE DES PIECES DE RECHANGE**

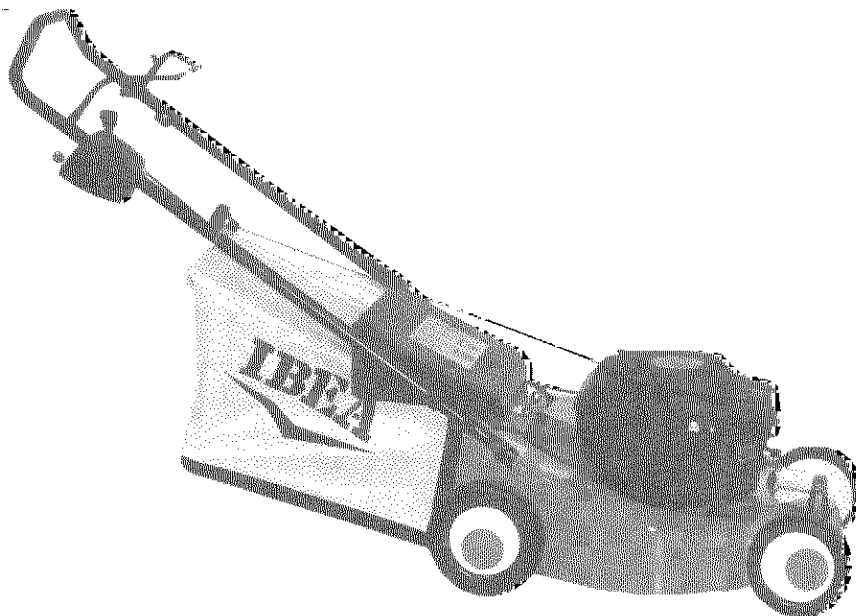

**SERIE 470**

6



8

7



9



10



12

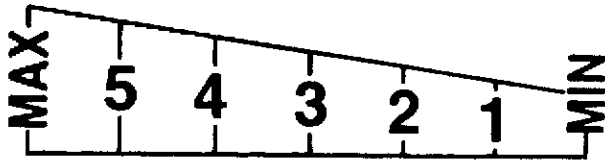

3



14

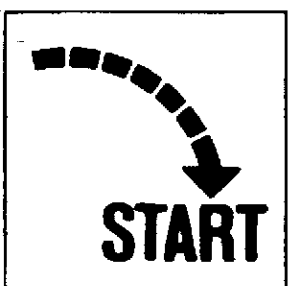

15



16



1E

7



REF. N°	PART. N°	QTY	DESCRIZIONE	DESCRIPTION	DESCRIPTION	BESCHREIBUNG
1		1	MOTORE	ENGINE	MOTEUR	MOTOR
2	P1050011	3	DADO	NUT	ÉCROU	MUTTER
3	1090001A1	1	CHIAVETTA	KEY	CLAVETTE	SCHIBENFEDER
4	P1010071		VITE	SCREW	VIS	SCHRAUBE
5	P1010070	2	VITE	SCREW	VIS	SCHRAUBE
6	P2020051		CARTER COPRICINGHIA	BELT COVER	COUVERCLE	DECKEL
7	1020014A1	2	RONDELLA	WASHER	RONDELLE	SCHIBE
8	2020050A1	2	POMELLO	KNOB	POIGNÉE	MUTTER
9	P1010154	2	VITE	SCREW	VIS	SCHRAUBE
10	P2020165	1	CAPOTTINA	ENGINE COVER	COUVERCLE MOTEUR	MOTORABDECKUNG
11	P1010153	2	VITE	SCREW	VIS	SCHRAUBE
11	1010026A1	2	VITE (SOLO IB-4721F)	SCREW (IB-4721F ONLY)	VIS (SEULEMENT IB-4721F)	SCHRAUBE (NUR IB-4721F)
12	P3020011	1	MOLLA	SPRING	RESSORT	FEDER
13	P2020058	1	PORTELLO	SHIELD	PROTECTION	KLAPPE
14	P3050051VE	1	SUPPORTO	HANDLEBAR SUPPORT	SUPPORT DE GUIDON	HOLMHALTER
15	P1050011	2	DADO	NUT	ÉCROU	MUTTER
16	P1060004	2	FISSATORE	WASHER	RONDELLE	SCHIBE
17	P01027080	1	ASTINA	SHAFT	ARBRE	ACHSE
18	P1010161	1	VITE	SCREW	VIS	SCHRAUBE
19	1020014A1	1	RONDELLA	WASHER	RONDELLE	SCHIBE
20	P2020053	1	CARTER	COVER	COUVERCLE	DECKEL
21	P4080016	2	SUPPORTO ASSALE	AXLE SUPPORT	SUPPORT ESSIEU	HALTER
22	1060002A1	2	ANELLO	NUT	ÉCROU	MUTTER
23	P4010215VE	1	ASTA	ROD	TIGE	STANGE
24	3040010A1	2	BULLONE	BOLT	BOULON	STIFT
25	P1010074	4	VITE	SCREW	VIS	SCHRAUBE
26	1020014A1	3	RONDELLA	WASHER	RONDELLE	SCHIBE
27	P1010098	1	VITE (B&S)	SCREW (B&S)	VIS (B&S)	SCHRAUBE (B&S)
28	P1010097	2	VITE (B&S)	SCREW (B&S)	VIS (B&S)	SCHRAUBE (B&S)
28	P1010135	3	VITE (TECNA)	SCREW (TECNA)	VIS (TECNA)	SCHRAUBE (TECNA)
29	P4090005VER	1	SCOCCA	MOWERDECK	CHÂSSIS	GEHAUSE
30	P1030005	1	BUSSOLA	BUSHING	DOUILLE	BÜCHSE
31	1020010A1	1	RONDELLA	WASHER	RONDELLE	SCHIBE
32	P1060017	1	COPPIGLIA	CIRCLIP	SEEGER	SEEGER
33	P2020055	1	CHIOCCIOLA	NUT	ÉCROU	MUTTER
34	1020007A1	1	RONDELLA	WASHER	RONDELLE	SCHIBE
35	P1010018	1	VITE	SCREW	VIS	SCHRAUBE
36	P3060087		MANIGLIA ALZARUOTA	HEIGHT ADJ. LEVER	LEVIER RÉG. HAUT. DE COUPE	HEBEL FÜR SCHNITTHÖHENVERSTEL
37	P3020030		MOLLA	SPRING	RESSORT	FEDER
38	P1020093		RONDELLA	SPACER	EPAISSEUR	SCHIBE
39	P00030380		ASSALE ANTERIORE	FRONT AXLE	ESSIEU AVANT	VORDERACHSE
40	P4080015	2	SUPPORT ASSALE	AXLE SUPPORT	SUPPORT ESSIEU	HALTER
41	P1010074	4	VITE	SCREW	VIS	SCHRAUBE
42	P3040102	1	BUSSOLA LAMA. A TRAZ	BLADE BUSHING, SELF-PROP.	DOUILLE DE LAME., TRACTÉ	MESSERBÜCHSE, MOD. MIT RADAN.
42	P3040254		BUSSOLA LAMA. A SPIN	BLADE BUSHING, PUSH MOD.	DOUILLE DE LAME, POUSSÉ	MESSERBÜCHSE, HANDGEST. MOD
43	P4050018		LAMA TOSAERBA	BLADE	LAME	MESSER
44	1110002A1	1	MOLLA	SPRING	RESSORT	FEDER
45	P1010050	1	VITE LAMA	BLADE SCREW	VIS DE COUPEAU	MESSERSCHRAUBE
46	P1020067	1	RONDELLA	WASHER	RONDELLE	SCHIBE
47	P1020050	2	RONDELLA	SPRING WASHER	RONDELLE ÉLASTIQUE	FEDERSCHIBE
48	P2020088	2	DISTANZIALE	SPACER	RONDELLE	DISTANZBÜCHSE
49	P2020377	2	COPRIRUOTA	WHEEL COVER	COUVERCLE DE ROUE	RADABDECKUNG
50	P3030013	4	CUSCINETTO	BEARING	PALIER	LAGER
51	P2020079	2	CERCHIO	RIM	FRETTE	FELGE
51	P2020378	2	CERCHIONE	HUB	JANTE	FELGE
52	P2020078	2	COPERTONE	TYRE	PNEU	REIFEN
53	1020007A1	2	RONDELLA	WASHER	RONDELLE	SCHIBE
54	1010018A1	2	VITE	SCREW	VIS	SCHRAUBE
55	P2080002	2	RUOTA	WHEEL ASS.Y	ROUE COMPL.	RAD KOMP.
56	P2020062	2	COPRIMOZZO	COVER	COUVERCLE	DECKEL
57		2	VEDI TAV. 3	SEE TAV. 3	VOIR TAV. 3	SIEHE TAV. 3
58	P1010125	1	VITE	SCREW	VIS	SCHRAUBE
59	P3050052VE	1	SUPPORTO	HANDLEBAR SUPPORT	SUPPORT DE GUIDON	HOLMHALTER
60	P3020014	1	MOLLA	SPRING	RESSORT	FEDER
61	P5050002	1	CAVO	CABLE	CÂBLE	KABEL
62	P2020148	1	DEFLETTORE	DEFLECTOR	DÉFLECTEUR	DEFLEKTOR
63	P2020104	1	SCIVOLO ERBA	GRASS CHUTE	DÉFLECTEUR À HERBE	DEFLEKTOR
64	P00011280	1	TELAIO CESTELLO	BAG FRAME	MONTURE	GESTELL
65	P3160032		SACCO	GRASS BAG	SAC DE RAMASSAGE	GRASFANGSACK

Assale posteriore, modello a spinta (IB-4721F)  
Rear axle, push model (IB-4721F)  
Essieux arrière, modèle à pousser (IB-4721F)  
Hinterachse, handgestoßen Modell (IB-4721F)

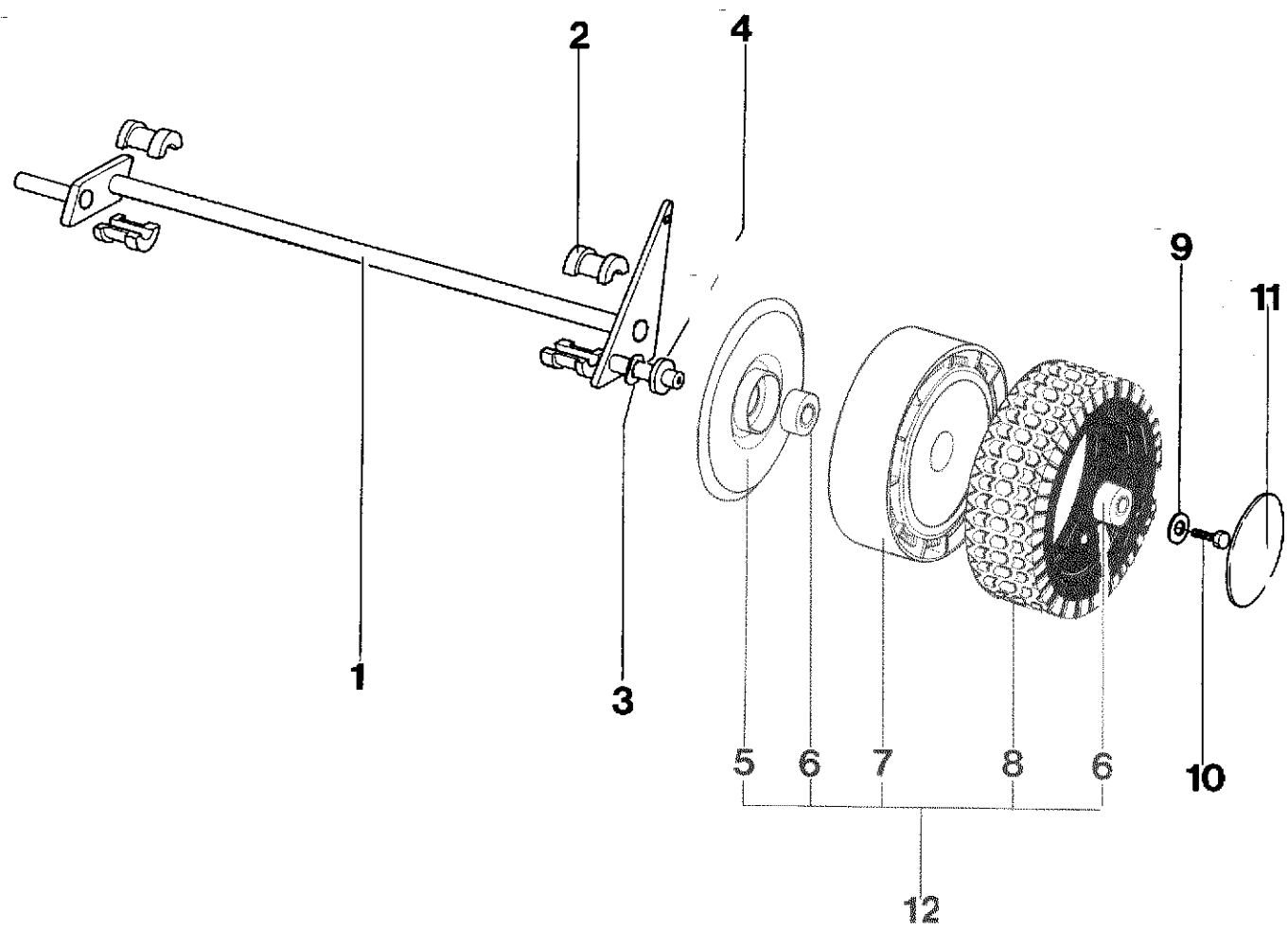

REF. N°	PART. N°	QTY	DESCRIZIONE	DESCRIPTION	DESCRIPTION	BESCHREIBUNG
1	P3060041ZT	1	ASSALE POST.	REAR AXLE SHAFT	ESSIEU ARRIÈRE	HINTRACHSE
2	P2020056	4	SEMIBUSSOLA	HALF BUSHING	SEMI DOUILLE	GETEILTE BÜCHSE
3	P1020050	2	RONDELLA	SPRING WASHER	RONDELLE ÉLASTIQUE	FEDERSCHEIBE
4	P2020088	2	DISTANZIALE	SPACER	RONDELLE	DISTANZBÜCHSE
5	P2020128	2	COPRIRUOTA	WHEEL COVER	PROTECTION	ABDECKUNG
6	P3030013	4	CUSCINETTO	BEARING	PALIER	LAGER
7	P2020082	2	CERCHIO	FRONT HUB	JANTE ANT.	FELGE
8	P2020083	2	COPERTONE	TYRE	PNEU	REIFEN
9	1020007A1	2	RONDELLA	WASHER	RONDELLE	SCHEIBE
10	1010018A1	2	VITE	SCREW	VIS	SCHRAUBE
11	P1020050	2	RONDELLA	SPRING WASHER	RONDELLE ÉLASTIQUE	FEDERSCHEIBE
12	P00015176	2	RUOTA COMPLETA	WHEEL ASS.Y	ROUE COMPL.	RAD KOMP.

Assale posteriore e trasmissione, modello a trazione (IB-4727F, IB-4728F, IB-4742F)  
 Rear axle and gear box, self-propelled model (IB-4727F, IB-4728F, IB-4742F)  
 Essieux arrière et transmission, modèle tracté (IB-4727F, IB-4728F, IB-4742F)  
 Hinterachse und Getriebe, Modell mit Radantrieb (IB-4727F, IB-4728F, IB-4742F)

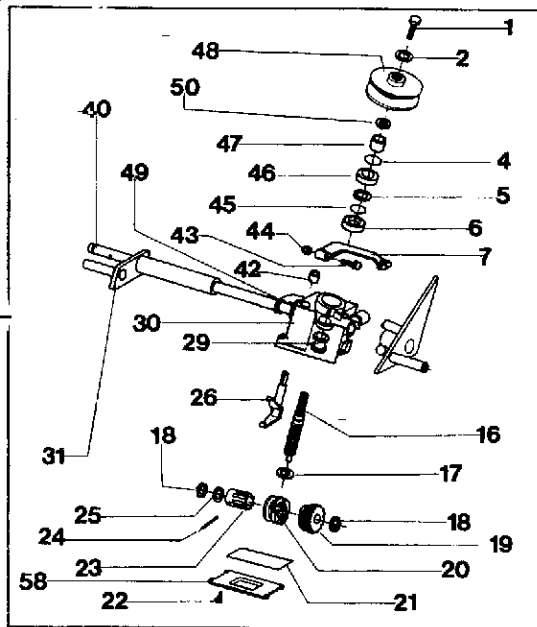
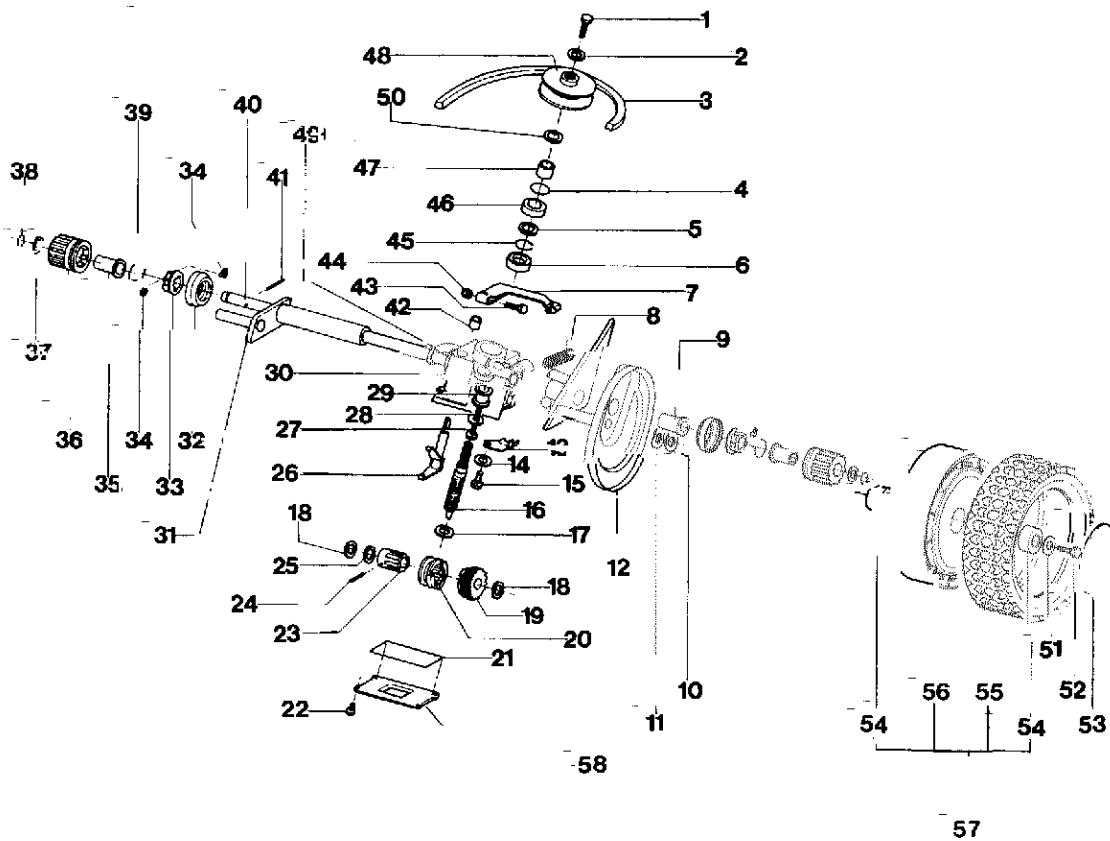

REF. N°	PART. N°	QTY	DESCRIZIONE	DESCRIPTION	DESCRIPTION	BESCHREIBUNG
1	1010018A1		VITE	SCREW	VIS	SCHRAUBE
2	1020007A1		RONDELLA	WASHER	RONDELLE	SCHEIBE
3	P3010027		CINGHIA	BELT	COURROIRE	RIEMEN
4	P3170013		O-RING	SPACER	DOUILLE	ABSTANDSSTÜCK
5	P1020051		RONDELLA	WASHER	RONDELLE	SCHEIBE
6	P3030010		CUSCINETTO	BEARING	PALIER	LAGER
7	P4070011		LEVA TRAZIONE	LEVER	LEVIER	HEBEL
8	P3020010		MOLLA	SPRING	RESSORT	FEDER
9	P2020070	2	BOCCOLA	BUSHING	DOUILLE	BÜCHSE
10	P2020088	2	DISTANZIALE	SPACER	RONDELLE	DISTANZBÜCHSE
11	P1020050	2	RONDELLA	SPRING WASHER	RONDELLE ÉLASTIQUE	FEDERSCHEIBE
12	P4030011	2	COPRIRUOTA	WHEEL COVER	PROTECTION	ABDECKUNG
13	P4030010	1	COPERCHIETTO	COVER	COUVERCLE	DECKEL
14	P1020055	1	RONDELLA	WASHER	RONDELLE	SCHEIBE
15	P1010076	1	VITE	SCREW	VIS	SCHRAUBE
16	P3040042	1	VITE SENZA FINE	WORM GEAR	VIS SANS FIN	SCHNECKE
17	P1020053	1	RONDELLA	SPACER	DOUILLE	ABSTANDSSTÜCK
18	1020020A1	2	RONDELLA	WASHER	RONDELLE	SCHEIBE
19	P00038199	1	RUOTA ELICOIDALE	WORM WHEEL	ROUE POUR VIS S. FIN	SCHNECKENRAD
20	P00038099	1	INNESTO	SELECTOR COLLAR	MANCHON	SCHALTBÜCHSE
21	P3170014	1	O-RING	O-RING	JOINT TORIQUE	GUMMIRING
22	P1010076	1	VITE	SCREW	VIS	SCHRAUBE
23	P3050030	1	BUSSOLA	BUSHING	DOUILLE CANNELÉE	KEILHÜLSE
24	P1080007	1	SPINA	PIN	GOUPILLE	STIFT
25	P1020051	1	RONDELLA	WASHER	RONDELLE	SCHEIBE
26	P3040041	1	FORCELLA	FORK	FOURCHE	GABEL
27	1010018A1	1	VITE	SCREW	VIS	SCHRAUBE
28	P1020054	1	RONDELLA	WASHER	RONDELLE	SCHEIBE
29	P2040010	1	ANTIVIBRANTE	RUBBER TUBE	TUBE DE PROTECTION	SCHUTZHÜLLE
30	P00039199	1	SCATOLA RIDUTTORE	GEARBOX HOUSING	BOÎTE DE VITESSE	GETRIEBE
31	P3060040ZT	1	ASSALE POST.	REAR AXLE SHAFT	ESSIEU ARRIÈRE	HINTERACHSE
32	P2020060	2	COPRIPIGNONE	CAGE	CAGE	KÄFIG
33	P2100001	2	CAMME	CAMME DRIVER	CLIQUETTE DE CAMME	MITNEHMER
34	P2110001	4	SALTERELLO	KEY	CLAVETTE	SCHEIBENFEDER
35	P2020059	2	BUSSOLA	BUSHING	DOUILLE	BÜCHSE
36	P3050031	2	RUOTA DENTATA	PINION	PIGNON	RITZEL
37	1020020A1	2	RONDELLA	WASHER	RONDELLE	SCHEIBE
38	1070001A1	2	SEEGER	CIRCLIP	SEEGER	SEEGER
39	P3020012	1	MOLLA	SPRING	RESSORT	FEDER
40	P3040047	1	ALBERO TRAZIONE	TRACTION SHAFT	ARBRE DE TRACTION	ANTRIEBSWELLE
41	P1080004	1	SPINA	PIN	GOUPILLE	STIFT
42	P3170012	1	ANELLO DI TENUTA	OIL SEAL	JOINT D'ARBRE	WELLENDICHTRING
43	P1010075	1	VITE	SCREW	VIS	SCHRAUBE
44	1050003A1	1	DADO	NUT	ÉCROU	MUTTER
45	P1070004	1	SEEGER	CIRCLIP	SEEGER	SEEGER
46	P3170010	1	ANELLO DI TENUTA	OIL SEAL	JOINT D'ARBRE	WELLENDICHTRING
47	P3040049	1	BUSSOLA	BUSHING	DOUILLE	BÜCHSE
48	P3040244	1	PULEGGIA	PULLEY	POULIE	RIEMENSCHLEIBE
49	P3170011	1	ANELLO DI TENUTA	OIL SEAL	JOINT D'ARBRE	WELLENDICHTRING
50	P1020104	2	SPESSORE	WASHER	RONDELLE	SCHEIBE
51	1020007A1	2	RONDELLA	WASHER	RONDELLE	SCHEIBE
52	1010018A1	2	VITE	SCREW	VIS	SCHRAUBE
53	P2020062	4	COPRIMOZZO	COVER	COUVERCLE	DECKEL
54	P3030013	2	CUSCINETTO	BEARING	PALIER	LAGER
55	P2020083	2	COPERTONE	TYRE	PNEU	REIFEN
56	P2020084	2	CERCHIO	REAR HUB	FRETTE ARRIÈRE	HINTERFELGE
57	P00015276	1	RUOTA	REAR WHEEL	ROUE ARRIÈRE	HINTERRAD
58	P4110001	1	COPERCHIO	COVER	COUVERCLE	DECKEL
59	P2090001		SCATOLA RIDUTT. COMPL.	GEAR BOX ASS.Y	TRANSMISSION COMPL.	FAHRGETRIEBE KOMP.

Assale posteriore e trasmissione, modello a trazione vario speed (IB-4717F)

Rear axle and gear box, self-propelled vario speed model (IB-4717F)

Essieux arrière et transmission, modèle tracté vario speed (IB-4717F)

Hinterachse und Getriebe, vario speed Modell mit Radantrieb (IB-4717F)

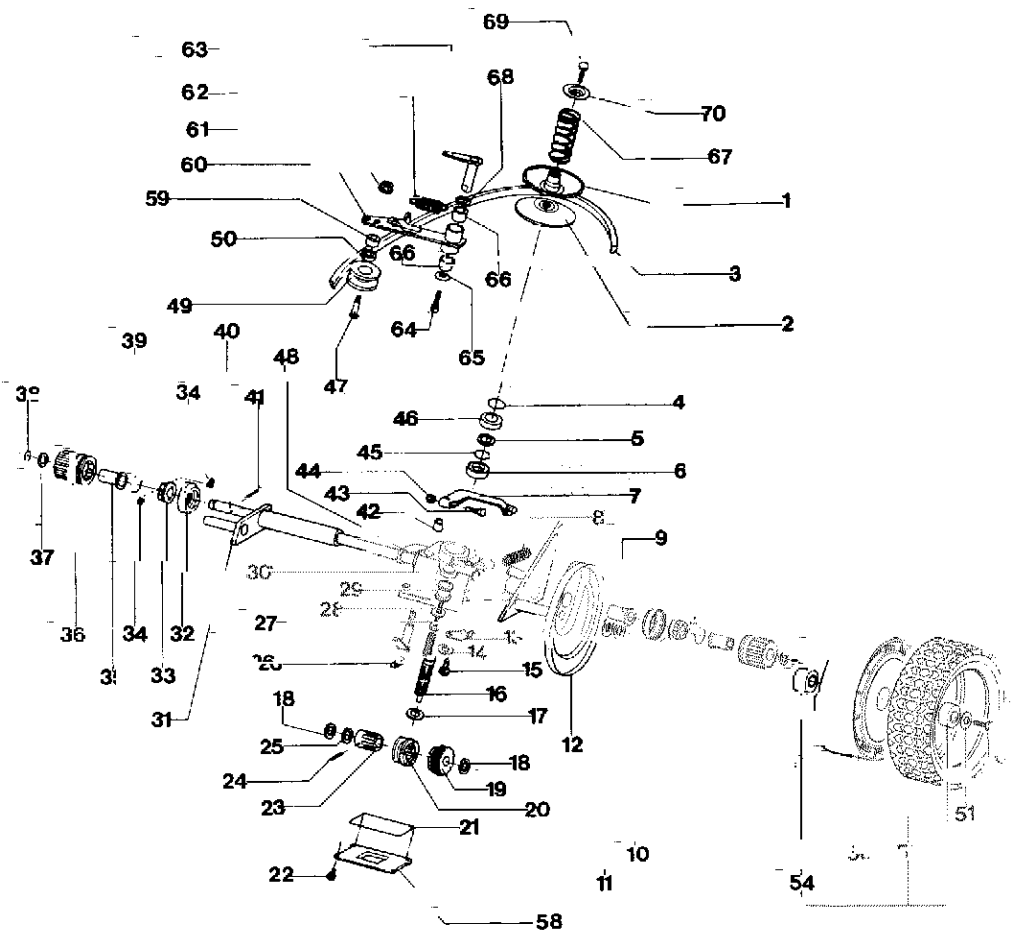

57

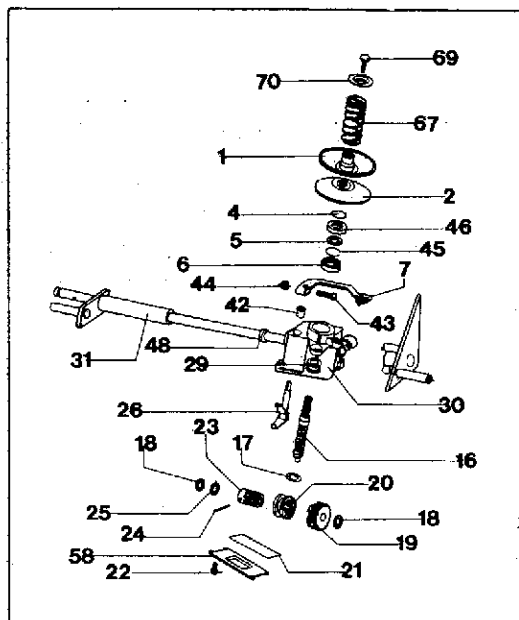

71



REF. N°	PART. N°	QTY	DESCRIZIONE	DESCRIPTION	DESCRIPTION	BESCHREIBUNG
1	P3040050		PULEGGIA SUPERIORE	UPPER PULLEY	POULIE SUPÉRIEUR	OBERE RIEMENSCHLEIBE
2	P3040051		PULEGGIA	PULLEY	POULIE	RIEMENSCHLEIBE
3	P3010011		CINGHIA	BELT	COURROIRE	RIEMEN
4	P3170013		O-RING	SPACER	DOUILLE	ABSTANDSSTÜCK
5	P1020051		RONDELLA	WASHER	RONDELLE	SCHLEIBE
6	P3030010		CUSCINETTO	BEARING	PALIER	LAGER
7	P4070011		LEVA TRAZIONE	LEVER	LEVIER	HEBEL
8	P3020010		MOLLA	SPRING	RESSORT	FEDER
9	P2020070	2	BOCCOLA	BUSHING	DOUILLE	BÜCHSE
10	P2020088	2	DISTANZIALE	SPACER	RONDELLE	DISTANZBÜCHSE
11	P1020050	2	RONDELLA	SPRING WASHER	RONDELLE ÉLASTIQUE	FEDERSCHLEIBE
12	P4030011	2	COPRIRUOTA	WHEEL COVER	PROTECTION	ABDECKUNG
13	P4030010	1	COPERCHIETTO	COVER	COUVERCLE	DECKEL
14	P1020055		RONDELLA	WASHER	RONDELLE	SCHLEIBE
15	P1010076		VITE	SCREW	VIS	SCHRAUBE
16	P3040043		VITE SENZA FINE	WORM GEAR	VIS SANS FIN	SCHNECKE
17	P1020053		RONDELLA	SPACER	DOUILLE	ABSTANDSSTÜCK
18	1020020A1	2	RONDELLA	WASHER	RONDELLE	SCHLEIBE
19	P00038199	1	RUOTA ELICOIDALE	WORM WHEEL	ROUE POUR VIS S. FIN	SCHNECKENRAD
20	P00038099	1	INNESTO	SELECTOR COLLAR	MANCHON	SCHALTBÜCHSE
21	P3170014		O-RING	O-RING	JOINT TORIQUE	GUMMIRING
22	P1010076	4	VITE	SCREW	VIS	SCHRAUBE
23	P3050030	1	BUSSOLA GUIDA	BUSHING	DOUILLE CANNELÉE	KEILHÜLSE
24	P1080007	1	SPINA	PIN	GOUPILLE	STIFT
25	P1020051		RONDELLA	WASHER	RONDELLE	SCHLEIBE
26	P3040041		FORCELLA	FORK	FOURCHE	GABEL
27	1010018A1	1	VITE	SCREW	VIS	SCHRAUBE
28	P1020054	1	RONDELLA	WASHER	RONDELLE	SCHLEIBE
29	P2040010	1	ANTIVIBRANTE	RUBBER TUBE	TUBE DE PROTECTION	SCHUTZHÜLLE
30	P00039199	1	SCATOLA RIDUTTORE	GEARBOX HOUSING	BOÎTE DE VITESSE	GETRIEBE
31	P3060040ZT	1	ASSALE POST.	REAR AXLE SHAFT	ESSIEU ARRIÈRE	HINTERACHSE
32	P2020060	2	COPRIPIGNONE	CAGE	CAGE	KÄFIG
33	P2100001	2	CAMME CRICCHETTO	CAMME DRIVER	CLIQUETTE DE CAMME	MITNEHMER
34	P2110001	4	SALTERELLO	KEY	CLAVETTE	SCHLEIBENFEDER
35	P2020059	2	BUSSOLA	BUSHING	DOUILLE	BÜCHSE
36	P3050031	2	RUOTA DENTATA	PINION	PIGNON	RITZEL
37	1020020A1	2	RONDELLA	WASHER	RONDELLE	SCHLEIBE
38	1070001A1	2	SEEGER	CIRCLIP	SEEGER	SEEGER
39	P3020012	2	MOLLA	SPRING	RESSORT	FEDER
40	P3040047	1	ALBERO TRAZIONE	TRACTION SHAFT	ARBRE DE TRACTION	ANTRIEBSWELLE
41	P1080004	2	SPINA	PIN	GOUPILLE	STIFT
42	P3170012	1	ANELLO DI TENUTA	OIL SEAL	JOINT D'ARBRE	WELLENDICHRING
43	P1010075	1	VITE	SCREW	VIS	SCHRAUBE
44	1050003A1	1	DADO	NUT	ÉCROU	MUTTER
45	P1070004		SEEGER	CIRCLIP	SEEGER	SEEGER
46	P3170010	1	ANELLO DI TENUTA	OIL SEAL	JOINT D'ARBRE	WELLENDICHRING
47	P3040068	1	PERNO	PIN	GOUPILLE	STIFT
48	P3170011	2	ANELLO DI TENUTA	OIL SEAL	JOINT D'ARBRE	WELLENDICHRING
49	P3040063		PULEGGIA	PULLEY	POULIE	RIEMENSCHLEIBE
50	P3030014		CUSCINETTO	BEARING	PALIER	LAGER
51	1020007A1	2	RONDELLA	WASHER	RONDELLE	SCHLEIBE
52	1010018A1	2	VITE	SCREW	VIS	SCHRAUBE
53	P2020062	2	COPRIMOZZO	COVER	COUVERCLE	DECKEL
54	P3030013	4	CUSCINETTO	BEARING	PALIER	LAGER
55	P2020083	2	COPERTONE	TYRE	PNEU	REIFEN
56	P2020207	2	CERCHIO POSTERIORE	REAR WHEEL HUB	JANTE POST.	FELGE
57	P00015276	2	RUOTA POST. COMPL.	WHEEL ASS.Y	ROUE COMPL.	RAD KOMPL.
58	P4110001	1	COPERCHIO	COVER	COUVERCLE	DECKEL
59	P3040064		DISTANZIALE	SPACER	ENTRETOISE	DISTANZBÜCHSE
60	P4010040		TENDICINGHIA	BELT TENSIONER	TENDEUR DE COURROIRE	RIEMENSPANNER
61	P1050011		DADO	NUT	ÉCROU	MUTTER
62	P3020033ZT		MOLLA	SPRING	RESSORT	FEDER
63	P4010041		PERNO	PIN	GOUPILLE	STIFT
64	P1010074		VITE	SCREW	VIS	SCHRAUBE
65	1020020A1	2	RONDELLA	WASHER	RONDELLE	SCHLEIBE
66	1030002A1	2	BUSSOLA	BUSHING	DOUILLE	BÜCHSE
67	P3020032	1	MOLLA	SPRING	RESSORT	FEDER
68	1020020A1	2	RONDELLA	WASHER	RONDELLE	SCHLEIBE
69	P1010066	1	VITE	SCREW	VIS	SCHRAUBE
70	P4010044	1	RONDELLA	WASHER	RONDELLE	SCHLEIBE
71	P2090003		SCATOLA VAR. COMPL.	GEARBOX ASS.Y	RÉDUCTEUR COMPL.	FAHRGETRIEBE KOMP.

Stegola superiore e comandi, modello a spinta (IB-4721F)  
 Upper handle and controls, self-propelled model (IB-4721F)  
 Guidon supérieur et éléments de commande, modèle tracté (IB-4721F)  
 Lenkeroberteil und Bedienungselemente, Modell mit Radantrieb (IB-4721F)

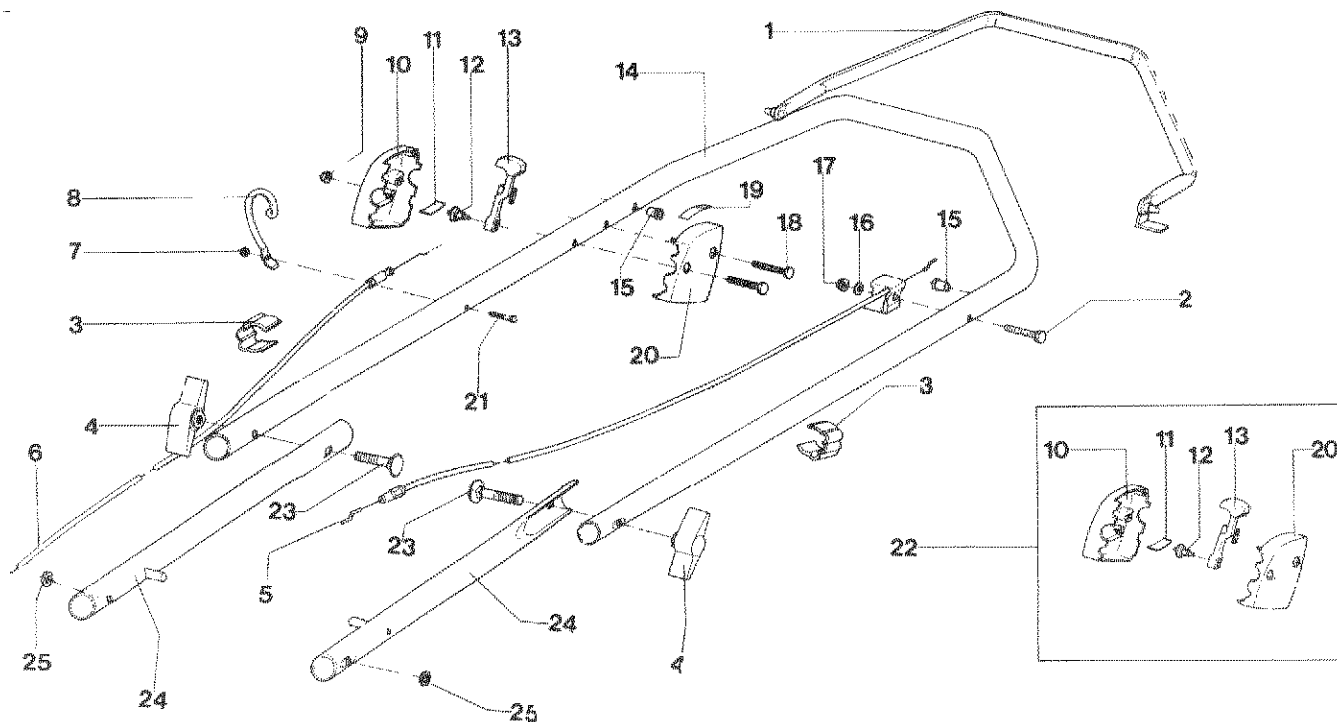

REF. N°	PART. N°	QTY	DESCRIZIONE	DESCRIPTION	DESCRIPTION	BESCHREIBUNG
1	P4080038VE	1	MANIGLIA SYSTEM 2	SYSTEM 2 LEVER	LEVIER SYSTEM 2	SYSTEM 2 HEBEL
2	P1010203	1	VITE	SCREW	VIS	SCHRAUBE
3	P2020080	2	FERMA CAVO	CLIP	CLIP	HALTER
4	2020060A1	2	DADO A GALLETTO	WING NUT	ÉCROU DE FIXATION	BEFESTIGUNGSMUTTER
5	P5010076	2	CAVO SYSTEM 2	SYSTEM 2 CABLE	CÂBLE SYSTEM 2	SYSTEM 2 KABEL
6	P5020038	1	CAVO ACCELERATORE	THROTTLE CABLE	CÂBLE DE GAZ	GASKABEL
7	1050002A1	2	DADO	NUT	ÉCROU	MUTTER
8	P01068343	1	SUPPORTO A RICCILO	STARTER HOLDER	SUPPORT	HALTER
9	1050003A1	1	DADO	NUT	ÉCROU	MUTTER
10	P2020106	1	SCATOLA ACC. DX	R.H. THROTTLE HOUSING	BOÎTE DE GAZ DROITE	GASGEHÄUSE R.
11	P4010059	2	MOLLA	SPRING	RESSORT	FEDER
12	P2020108	1	NOTTOLINO	BOLT	BOULON	STIFT
13	P00065099	1	LEVA ACCELERATORE	THROTTOLE LEVER	LEVIER DE COMMANDE	GASHEBEL
14	P3120103VE	1	STEGOLA SUPERIORE	UPPER HANDLEBAR	GUIDON SUPÉRIEUR	OBERE FÜHRUNGSHOLM
15	P2020153	2	BUSSOLA	BUSHING	DOUILLE	BÜCHSE
16	1020013A1	1	RONDELLA	WASHER	RONDELLE	SCHEIBE
17	1050003A1	1	DADO	NUT	ÉCROU	MUTTER
18	P1010102	2	VITE	SCREW	VIS	SCHRAUBE
19	P5140552	1	DECALCO ACCELER.	DECAL	MARQUAGE	AUFKLEBER
20	P2020107	1	SCATOLA ACC. SX	L.H. THROTTLE HOUSING	BOÎTE DE GAZ GAUCHE	GASGEHÄUSE L.
21	1010002A1	1	VITE	SCREW	VIS	SCHRAUBE
22	P00035099	1	SCATOLA ACC. COMPL.	THROTTLE HOUSING ASS.Y	BOÎTE DE GAS COMPL.	GASGEHÄUSE KOMP.
23	1010026A1	2	VITE	SCREW	VIS	SCHRAUBE
24	P3120122VE	2	STEGOLA INFERIORE	LOWER HANDLEBAR	GUIDON INFÉRIEUR	HUNTERE FÜHRUNGSHOLM
25	1020014A1	2	RONDELLA	WASHER	RONDELLE	SCHEIBE

Stegola superiore e comandi, modello a trazione (IB-4727F, IB-4728F, IB-4742F)  
Upper handle and controls, self-propelled model (IB-4727F, IB-4728F, IB-4742F)  
Guidon supérieur et éléments de commande, modèle tracté (IB-4727F, IB-4728F, IB-4742F)  
Lenkeroberteil und Bedienungselemente, Modell mit Radantrieb (IB-4727F, IB-4728F, IB-4742F)

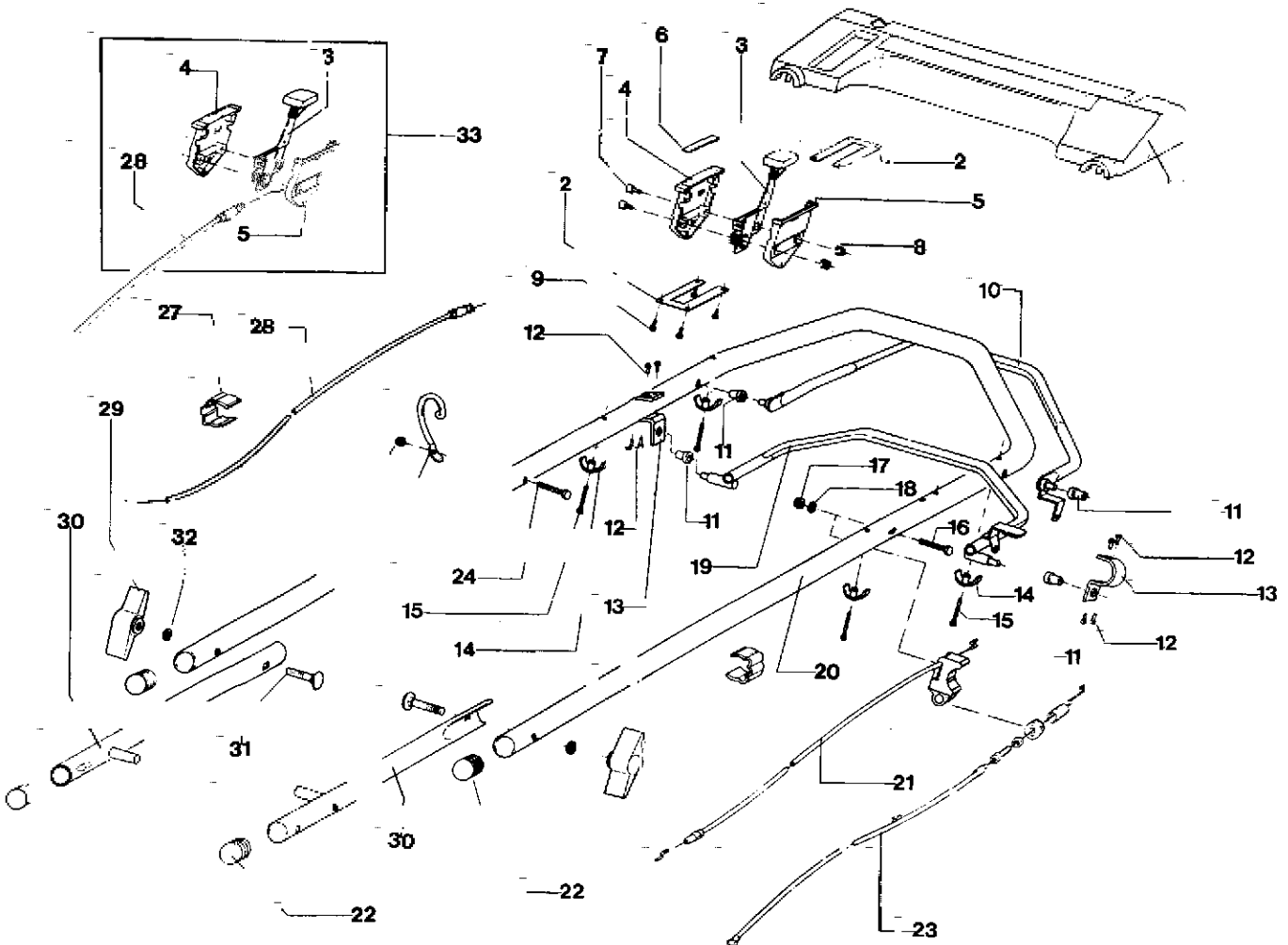

REF. N°	PART. N°	QTY	DESCRIZIONE	DESCRIPTION	DESCRIPTION	BESCHREIBUNG
1	P2020367	1	PANNELLO DI CONTROL.	CONTROL PANEL	PANNEAU DE CONTRÔLE	SCHALTTAFEL
2	P4010217ZT	2	SOSTEGNO	SUPPORT	SUPPORT	HALTER
3	P3090006	1	LEVA ACCELERATORE	THROTTLE LEVER	LEVIER DE GAZ	GASHEBEL
4	P2020366	1	SEMISCATOLA COM. DX	HALF HOUSING, R.H.	SEMI-BOÎTE DROITE	HALBGEHÄUSE, R.
5	P2020365	1	SEMISCATOLA COM. SX	HALF HOUSING, L.H.	SEMI-BOÎTE GAUCHE	HALBGEHÄUSE, L.
6	P5140547	1	DECALCO	DECAL	MARQUAGE	AUFKLEBER
7	P1010207	2	VITE	SCREW	VIS	SCHRAUBE
8	1050002A1	2	DADO	NUT	ÉCROU	MUTTER
9	P1010205	4	VITE	SCREW	VIS	SCHRAUBE
10	P4080033VE	1	MANIGLIA TRAZIONE	TRACTION LEVER	LEVIER DE TRACTION	ANTRIEBSHEBEL
11	P3040123	4	BUSSOLA	BUSHING	DOUILLE	BÜCHSE
12	P1020106	8	RIVETTO	RIVET	RIVET	NIET
13	P4010222ZN	2	SUPPORTO	SUPPORT	SUPPORT	HALTER
14	P2020369	4	CAVALLOTTO	RETAINER	ARRÊT	HALTER
15	P1010204	4	VITE	SCREW	VIS	SCHRAUBE
16	P1010203	1	VITE	SCREW	VIS	SCHRAUBE
17	1050003A1	1	DADO	NUT	ÉCROU	MUTTER
18	1020013A1	1	RONDELLA	WASHER	RONDELLE	SCHEIBE
19	P4080034VE	1	MANIGLIA SYSTEM 2	SYSTEM 2 LEVER	LEVIER SYSTEM 2	SYSTEM 2 HEBEL
20	P3120116VE	1	STEGOLA	HANDLEBAR	GUIDON	FÜHRUNGSHOLM
21	P5010052	1	CAVO SYSTEM 2	SYSTEM 2 CABLE	CÂBLE SYSTEM 2	SYSTEM 2 KABEL
21	P5010065	1	CAVO SYSTEM 2 (4742F)	SYSTEM 2 CABLE (4742F)	CÂBLE SYSTEM 2 (4742F)	SYSTEM 2 KABEL (4742F)
22	P2020142	2	TAPPO	PLUG	BOUCHON	PFROPFEN
23	P5010058	1	CAVO TRAZIONE	TRACTION CABLE	CÂBLE DE TRACTION	ANTRIEBSKABEL
24	1010002A1	1	VITE	SCREW	VIS	SCHRAUBE
25	P01068343	1	SUPPORTO A RICCILO	STARTER HOLDER	SUPPORT	HALTER
26	1050002A1	1	DADO	NUT	ÉCROU	MUTTER
27	P2020080	2	FERMA CAVO	CLIP	CLIP	HALTER
28	P5020065	1	CAVO ACCELERATORE	THROTTLE CABLE	CÂBLE DE GAZ	GASKABEL
28	P5020072	1	CAVO ACCEL. (4742F)	THROTTLE CABLE (4742F)	CÂBLE DE GAZ (4742F)	GASKABEL (4742F)
29	2020050A1	2	GALLETTO	WING NUT	ÉCROU DE FIXATION	BEFESTIGUNGSMUTTER
30	P3120114VE	2	STEGOLA INFERIORE	LOWER HANDLEBAR	GUIDON INFÉRIEUR	HOLMUNTERTEIL
31	P1010153	2	VITE	SCREW	VIS	SCHRAUBE
32	1020014A1	2	RONDELLA	WASHER	RONDELLE	SCHEIBE
33	P3080001	1	SCATOLA ACC. COMPL.	THROTTLE HOUSING ASS.Y	BOÎTE DE GAZ COMP.	GASGEHÄUSE KOMP.

Stegola superiore e comandi, modello a trazione vario speed (IB-4717F)  
Upper handle and controls, self-propelled vario speed model (IB-4717F)  
Guidon supérieur et éléments de commande, modèle tracté vario speed (IB-4717F)  
Lenkeroberteil und Bedienungselemente, vario speed Modell mit Radantrieb (IB-4717F)

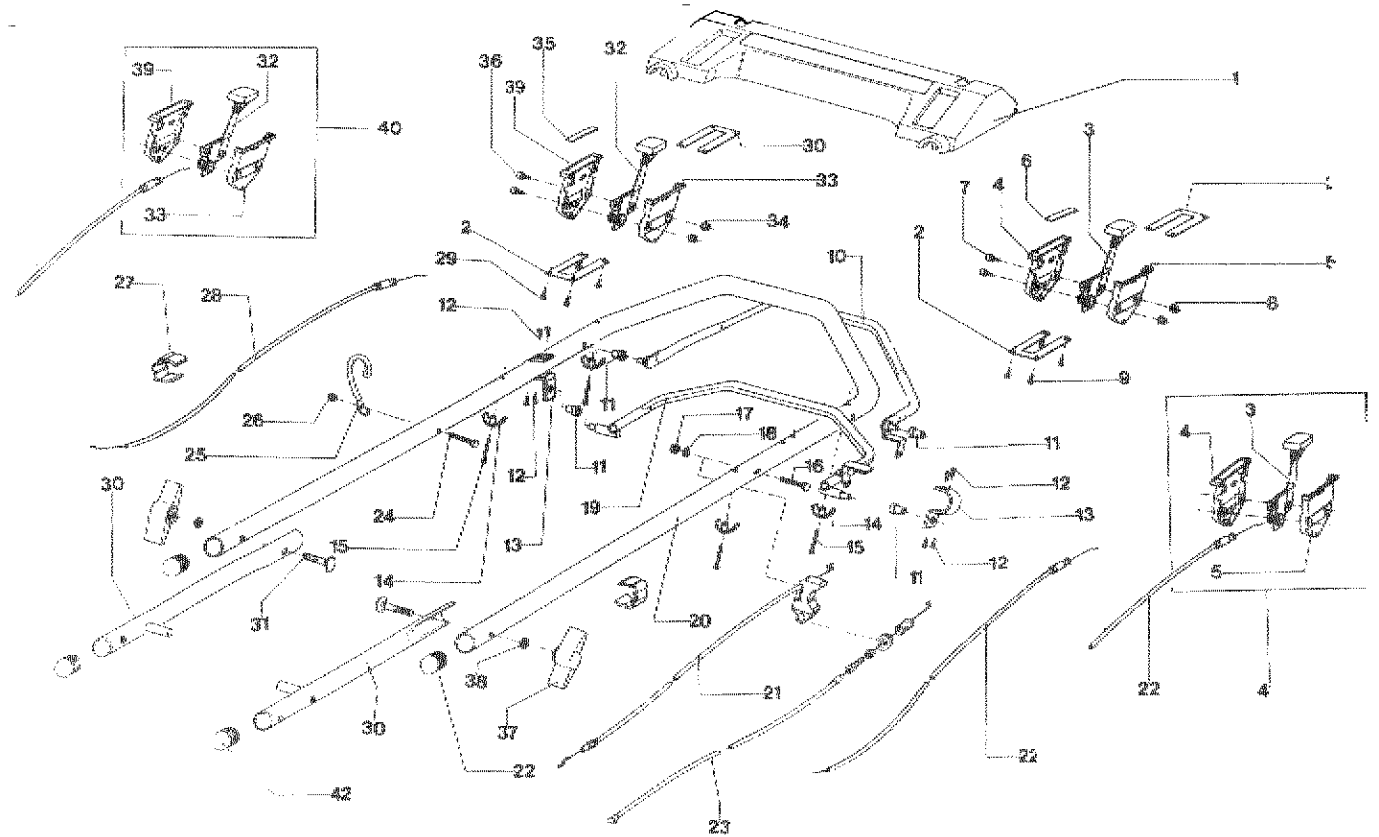

REF. N°	PART. N°	QTY	DESCRIZIONE	DESCRIPTION	DESCRIPTION	BESCHREIBUNG
1	P2020368	1	PANNELLO DI CONTROL.	CONTROL PANEL	PANNEAU DE CONTRÔLE	SCHALITAFEL
2	P4010217ZT	2	SOSTEGNO	SUPPORT	SUPPORT	HALTER
3	P3090008	1	LEVA VARIATORE	VARIABLE SPEED LEVER	LEVIER VARIATION VITESSE	VARIO GASHEBEL
4	P2020366	1	SEMISCATOLA COM. DX	HALF HOUSING, R.H.	SEMI-BOÎTE DROITE	HALBGEHÄUSE, R.
5	P2020365	1	SEMISCATOLA COM. SX	HALF HOUSING, L.H.	SEMI-BOÎTE GAUCHE	HALBGEHÄUSE, L.
6	P5140548	1	DECALCO	DECAL	MARQUAGE	AUFKLEBER
7	P1010207	2	VITE	SCREW	VIS	SCHRAUBE
8	1050002A1	2	DADO	NUT	ÉCROU	MUTTER
9	P1010205	4	VITE	SCREW	VIS	SCHRAUBE
10	P4080033VE	1	MANIGLIA TRAZIONE	TRACTION LEVER	LEVIER DE TRACTION	ANTRIEBSHEBEL
11	P3040123	4	BUSSOLA	BUSHING	DOUILLE	BÜCHSE
12	P1020106	8	RIVETTO	RIVET	RIVET	NIET
13	P4010222ZN	2	SUPPORTO	SUPPORT	SUPPORT	HALTER
14	P2020369	4	CAVALLOTTO	RETAINER	ARRÊT	HALTER
15	P1010204	4	VITE	SCREW	VIS	SCHRAUBE
16	P1010203	1	VITE	SCREW	VIS	SCHRAUBE
17	1050003A1	1	DADO	NUT	ÉCROU	MUTTER
18	1020013A1	1	RONDELLA	WASHER	RONDELLE	SCHEIBE
19	P4080034VE	1	MANIGLIA SYSTEM 2	SYSTEM 2 LEVER	LEVIER SYSTEM 2	SYSTEM 2 HEBEL
20	P3120116VE	1	STEGOLA SUPERIORE	UPPER HANDLEBAR	GUIDON SUPÉRIEUR	OBERE FÜHRUNGSHOLM
21	P5010052	1	CAVO SYSTEM 2	SYSTEM 2 CABLE	CÂBLE SYSTEM 2	SYSTEM 2 KABEL
22	P5010055	1	CAVO VARIATORE	VARIABLE SPEED CABLE	CÂBLE VARIATION VITESSE	VARIO KABEL
23	P5010058	1	CAVO TRAZIONE	TRACTION CABLE	CÂBLE DE TRACTION	ANTRIEBSKABEL
24	1010002A1	1	VITE	SCREW	VIS	SCHRAUBE
25	P01068343	1	SUPPORTO A RICCIOLIO	STARTER HOLDER	SUPPORT	HALTER
26	1050002A1	1	DADO	NUT	ÉCROU	MUTTER
27	P2020080	2	FERMA CAVO	CLIP	CLIP	HALTER
28	P5020065	1	CAVO ACCELERATORE	THROTTLE CABLE	CÂBLE DE GAZ	GASKABEL
29	P1010205	4	VITE	SCREW	VIS	SCHRAUBE
30	P3120114VE	2	STEGOLA INFERIORE	LOWER HANDLEBAR	GUIDON INFÉRIEUR	HUNTERE FÜHRUNGSHOLM
31	P1010153	2	VITE	SCREW	VIS	SCHRAUBE
32	P3090006	1	LEVA ACCELERATORE	THROTTLE LEVER	LEVIER DE GAZ	GASHEBEL
33	P2020365	1	SCATOLA ACC. SX	L.H. THROTTLE HOUSING	BOÎTE DE GAZ GAUCHE	GASGEHÄUSE L
34	1050002A1	2	DADO	NUT	ÉCROU	MUTTER
35	P5140547	1	DECALCO	DECAL	AUTOCOLLANT	AUFKLEBER
36	P1010207	2	VITE	SCREW	VIS	SCHRAUBE
37	2020050A1	2	DADO A GALLETTO	WING NUT	ÉCROU DE FIXATION	BEFESTIGUNGSMUTTER
38	1020014A1	2	RONDELLA	WASHER	RONDELLE	SCHEIBE
39	P2020366	1	SCATOLA ACC. DX	R.H. THROTTLE HOUSING	BOÎTE DE GAZ DROITE	GASGEHÄUSE R.
40	P3080003	1	SCATOLA VARIO COMPL.	VARIO SPEED HOUSING ASS.Y	BOÎTE DE VITESSE COMPL.	GEHÄUSE KOMP. (VARIO SPEED)
41	P3080001	1	SCATOLA ACC. COMPL.	THROTTLE HOUSING ASS.Y	BOÎTE DE GAZ COMPL.	GASGEHÄUSE KOMP.
42	P2020142	2	TAPPO	PLUG	BOUCHON	PFROPFEN

Avviamento elettrico (IB-4728F)  
Electric start (IB-4728F)  
Démarrage électrique (IB-4728F)  
Elektrostarter (IB-4728F)

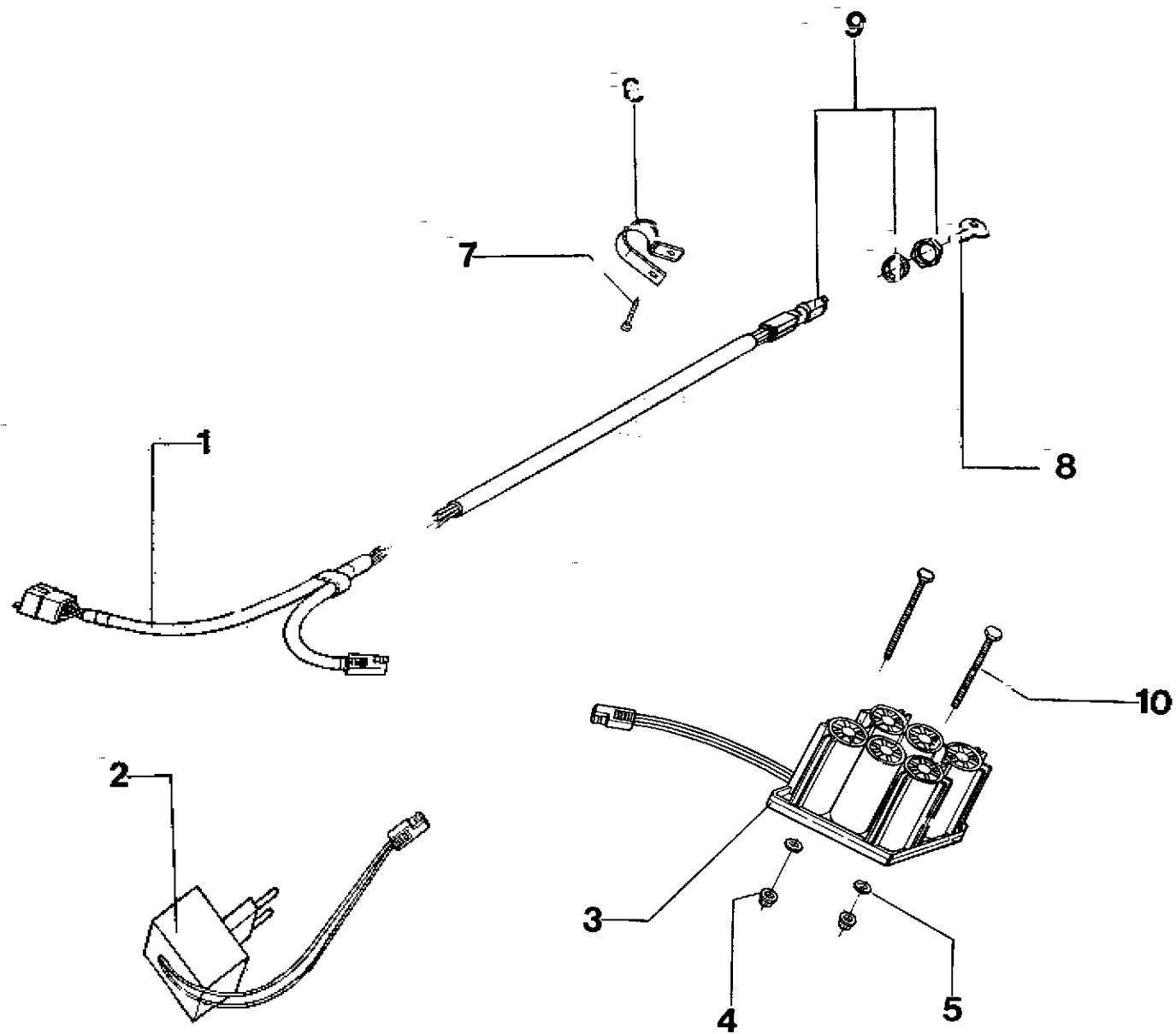



REF. N°	PART. N°	QTY	DESCRIZIONE	DESCRIPTION	DESCRIPTION	BESCHREIBUNG
1	P5030021	1	CAVO ELETTRICO	WIRE	CÂBLE ÉLECTRIQUE	KABEL
2	P5030009	1	CARICA BATTERIA	BATTERY CHARGER	CHARGEUR D'ACCUMULAT.	LADEGERÄT
3	P5030008	1	BATTERIA 12V	BATTERY 12V	BATTERIE 12V	BATTERIE 12V
4	1050002A1	2	DADO	NUT	ÉCROU	MUTTER
5	P1020055	2	RONDELLA	WASHER	RONDELL E	SCHEIBE
6	P5040005	1	FASCETTA	CABLE RETAINER	CLIP	HALTER
7	P1010209	3	VITE	SCREW	VIS	SCHRAUBE
8	P5030011	2	CHIAVE AVVIAM.	IGNITION KEY	CLÉ DE CONTACT	SCHLÜSSEL
9	P5030010	1	BLOCCHETTO AVV. EL.	KEY SWITCH	INTERRUPTEUR	SCHLÜSSELSCHALTER
10	P1010077	2	VITE	SCREW	VIS	SCHRAUBE

REF. N°	PART. N°	QTY	DESCRIZIONE	DESCRIPTION	DESCRIPTION	BESCHREIBUNG
1	P5140532		DECALCO	DECAL	AUTOCOLLANT	AUFKLEBER
2	P5140334		DECALCO	DECAL	AUTOCOLLANT	AUFKLEBER
3	P5140596		DECALCO	DECAL	AUTOCOLLANT	AUFKLEBER
4	P5140337		DECALCO	DECAL	AUTOCOLLANT	AUFKLEBER
5	P5140545		DECALCO	DECAL	AUTOCOLLANT	AUFKLEBER
6	P5140549		DECALCO	DECAL	AUTOCOLLANT	AUFKLEBER
7	P5140531		DECALCO	DECAL	AUTOCOLLANT	AUFKLEBER
8	P5140547		DECALCO	DECAL	AUTOCOLLANT	AUFKLEBER
9	P5140534		DECALCO	DECAL	AUTOCOLLANT	AUFKLEBER
10	P5140645		DECALCO	DECAL	AUTOCOLLANT	AUFKLEBER
11	P2020138		DECALCO	DECAL	AUTOCOLLANT	AUFKLEBER
12	P5140652		DECALCO	DECAL	AUTOCOLLANT	AUFKLEBER
13	P5140101		DECALCO	DECAL	AUTOCOLLANT	AUFKLEBER
14	P5140110		DECALCO	DECAL	AUTOCOLLANT	AUFKLEBER
15	P5140109		DECALCO	DECAL	AUTOCOLLANT	AUFKLEBER
16	P5140631		DECALCO	DECAL	AL TOCCIA	AUFKLEBER
17	P5140555		DECALCO	DECAL	AL TOCCIA	AUFKLEBER
18	P5140548		DECALCO	DECAL	AL TOCCIA	AUFKLEBER
*	P5110008		CHIAVE TUBO	KEY	CLIF	SCHLÜSSEL
*	P5090222 I/E		MANUALE ISTRUZIONI	INSTRUCTION MANUAL	MODE D'EMPLOI	BEDIENUNGSANLEITUNG

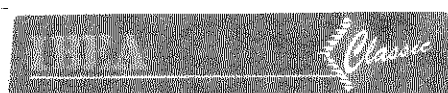

2

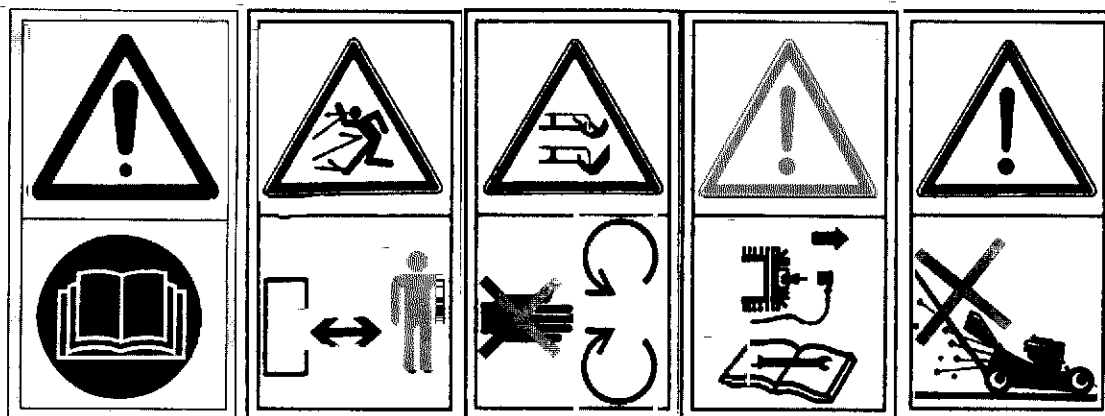

3



4

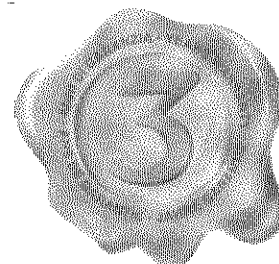

5

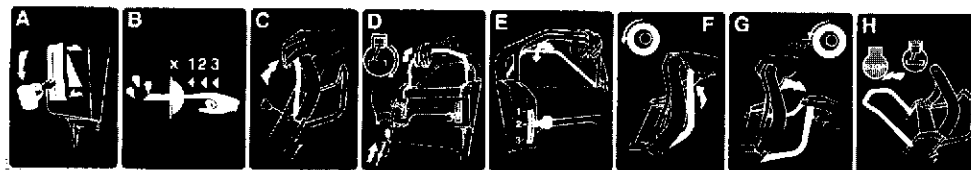

Vista generale  
Complete machine  
Vue d'ensemble  
Gesamtansicht

