

Reihennummer	Artikelnummer	Menge	Description
1	SA35597	1	RIEMENSCHLEIBE
2	SA15776	1	STELLSCHRAUBE M6X16
3	SA36523	1	KEILRIEMEN
4	SA16053	2	SPANNROLLE
5	SA29725	1	HALTER *
6	SA15413	2	MUTTER (A) M8
7	SA15233	2	FEDERRING (A) A8
8	SA15229	1	UNTERLEGSCHEIBE A5,3
9	SA29854	1	SCHRAUBE * M5X12
10	SA36541	1	ZUGFEDER
11	SA11998	1	SICHERUNGSMUTTER (A) M8
12	SA15213	1	UNTERLEGSCHEIBE (A) A8,4
13	SA34925	1	ARM
14	SA17726	1	BUECHSE
15	SA15207	1	UNTERLEGSCHEIBE (A) A15
16	SA15365	1	SECHSKANTSCHRAUBE M8X35
17	SA30451	1	RIEMENSCHLEIBE ASSY
18	SA15202	1	UNTERLEGSCHEIBE (A) 6,4
19	SA19260	1	SCHRAUBE * M6X60
20	SA36495	1	RAHMEN ASSY (INCL KEYS SA29724, SA36655)
21	SA36495	2	RAHMEN (SUB FOR SA36655)
22	SA29724	2	FEDERKLEMME
23	SA36494	1	GRASFANGBEHAELTER (A) WERDEN NUR NOCH IN PACKMENGEN GELIEFERT

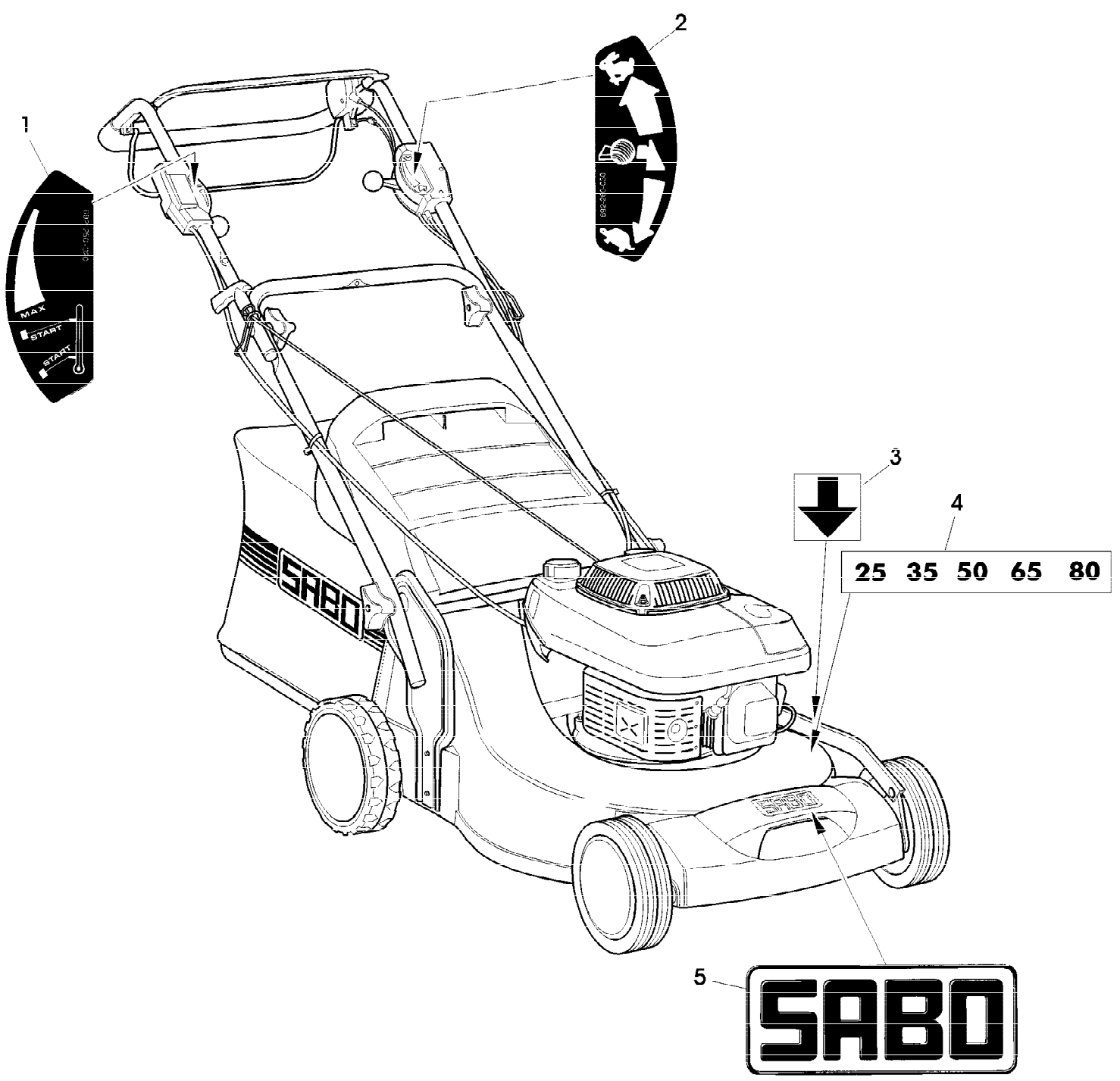

---

Reihennummer	Artikelnummer	Menge	Description
1	SA34135	1	AUFKLEBER
2	SA33217	1	AUFKLEBER
3	SA13820	1	AUFKLEBER
4	SA36672	1	AUFKLEBER
5	SA36391	1	AUFKLEBER (SUB FOR SA36482)

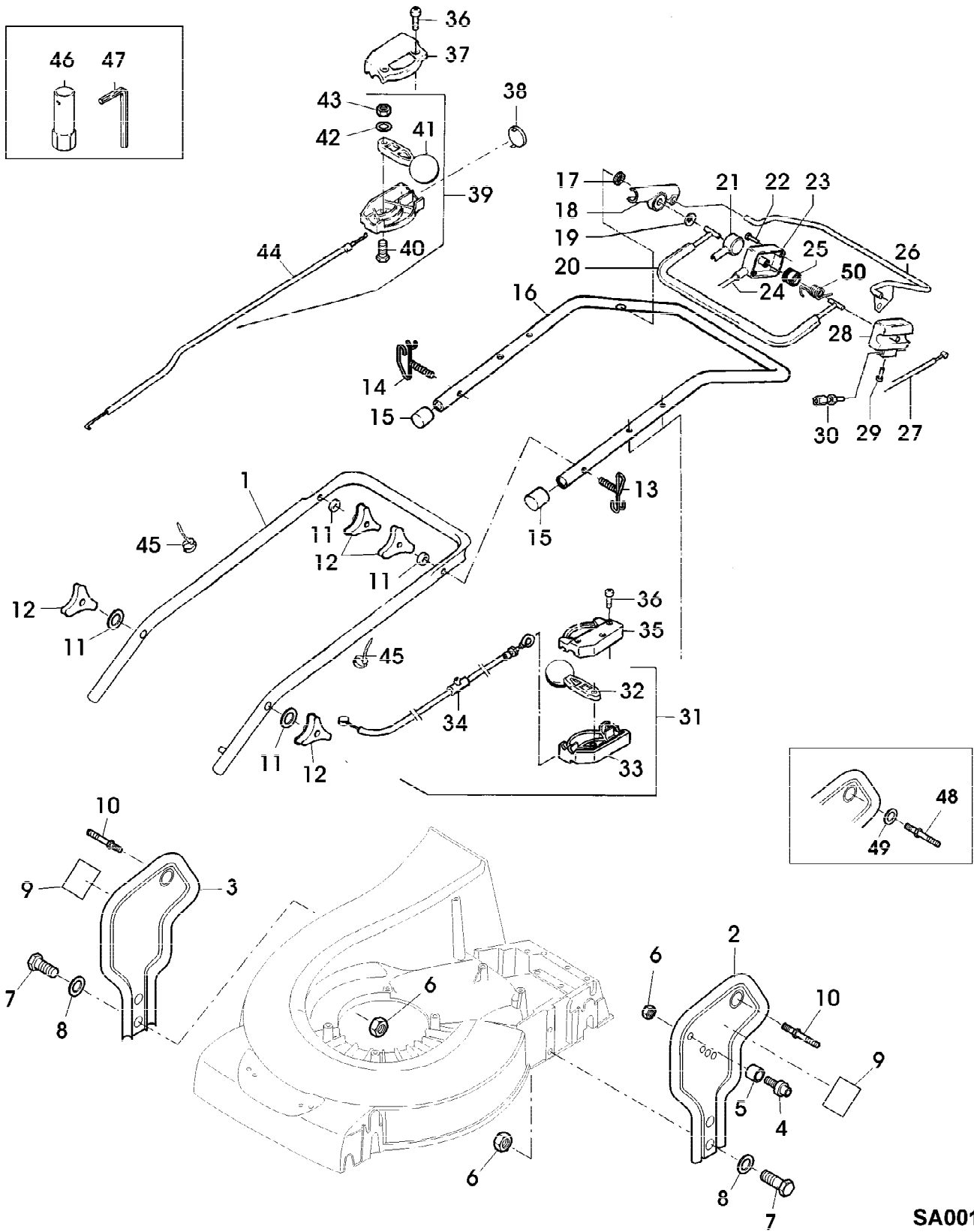

Reihennummer	Artikelnummer	Menge	Description
1	SA36505	1	FUEHRUNG LOW
2	SA36507	1	HALTER * LH
3	SA36506	1	HALTER * RH
4	SA15569	1	SCHRAUBE * M8X25
5	SA35927	1	DISTANZSTUECK
6	SA11998	5	SICHERUNGSMUTTER (A) M8
7	SA15334	4	SECHSKANTSCHRAUBE M8X30
8	SA35420	4	SCHEIBE 8,4
9	SA36668	2	SCHEUERSCHUTZ
10	SA36663	2	BOLZEN (ORD SA36986, SA15203) [-002675]
11	SA30444	4	SCHEIBE
12	SA29799	4	MUTTER 8MM
13	SA35200	1	FUEHRUNG 8MM
14	SA35437	1	FUEHRUNG
15	SA34255	2	STOPFEN (A)
16	SA36522	1	LENKSTANGE UP
17	SA34247	1	RING
18	SA34662	1	LAGER RH
19	SA34089	1	SCHEIBE
20	SA34013	1	BUEGEL (B)
21	SA33951	1	ABDECKUNG RH
22	SA31423	2	SCHRAUBE * KB 35X20
23	SA33952	1	GEHAEUSE *
24	SA36645	1	SEILZUG (B)
25	SA33955	1	ROLLE
26	SA36665	1	BUEGEL (C)
27	SA36652	1	SEILZUG (C)
28	SA34831	1	GEHAEUSE *
29	SA33975	2	SCHRAUBE * KB 40X35
30	SA34098	1	STELLSCHRAUBE
31	SA36543	1	STEUERUNG ASSY, LOW
32	SA34001	1	HEBEL
33	SA33209	1	GEHAEUSE * LOW
34	SA36543	1	STEUERUNG (SUB FOR SA36545)
35	SA33208	1	GEHAEUSE * UP
36	SA16268	5	SCHRAUBE * 4,2X32
37	SA31188	1	GEHAEUSE * UP
38	SA31709	1	STOPFEN
39	SA36650	1	STEUERUNG ASSY, LOW
40	SA15325	1	SECHSKANTSCHRAUBE M6X30
41	SA12768	1	HEBEL
42	SA15202	1	UNTERLEGSCHEIBE 6,4
43	SA11244	1	SICHERUNGSMUTTER (A) M6
44	SA36650	1	STEUERUNG (SUB FOR SA36649)
45	SA15273	5	KABELBINDER 151MM
46	SA35231	1	SCHLUESSEL
47	SA18332	1	MAUL-RINGSCHLUESSEL 5/16
48	SA36986	2	BOLZEN [002676-]
49	SA15203	2	UNTERLEGSCHEIBE A 8,4 [002676-]
50	SA34624	1	FEDER [002676-]

(A) WERDEN NUR NOCH IN PACKMENGEN  
 GELIEFERT

---

Preisnummer	Artikelnummer	Menge	Description
			(B) FUER MOTORBREMSE
			(C) FUER FAHRANTRIEB

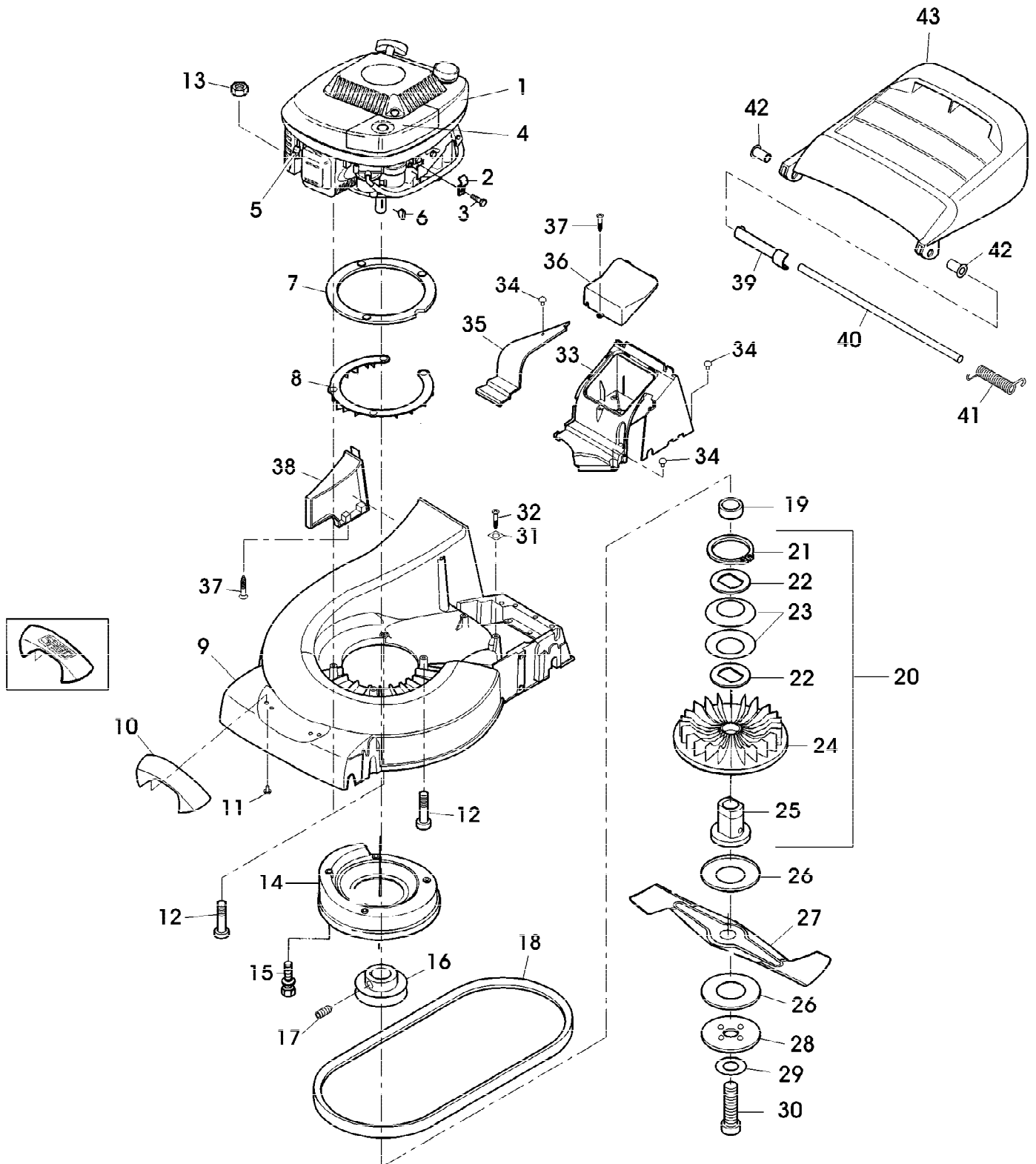



## GEHAEUSE, MOTOR, LUEFTER, MESSERBALKEN, AUSWURF

Reihennummer	Artikelnummer	Menge	Description
1	SA35227	1	BENZINMOTOR KAWASAKI FC150 V MODEL GS67 SUB FOR MODEL ES67
2	SA26799	1	KLEMME
3	SA26798	1	SCHRAUBE *
4	SA35945	1	LUFTFILTEREINSATZ PAPER
	SA35944	1	VORFILTER
5	SA32641	1	ZUENDKERZE
6	SA15967	2	KEIL * 4X6,5
7	SA36239	1	RING
8	SA36670	1	SCHUTZ
9	SA36686	1	MAEHGEHAEUSE
10	SA36405	1	GRIFF * (INCL KEY SA36391)
11	SA35503	2	SCHRAUBE * CM 60X20
12	SA15573	3	SCHRAUBE * M8X50
13	SA11998	3	SICHERUNGSMUTTER (A) M8
14	SA36683	1	LUEFTERHAUBE
15	SA29854	4	SCHRAUBE * M5X12
16	SA35597	1	RIEMENSCHLEIFE
17	SA15776	1	STELLSCHRAUBE M6X16
18	SA36523	1	KEILRIEMEN
19	SA12788	1	DISTANZSTUECK
20	SA36486	1	LUEFTER ASSY
21	SA15739	1	SPRENGRING 31X1,5
22	SA11896	2	UNTERLEGSCHLEIFE
23	SA15179	2	TELLERFEDER (A)
24	SA36487	1	LUEFTERFLUEGEL
25	SA36498	1	FLANSCH
26	SA35386	2	BELAG (A)
27	SA17208	1	MESSER
28	SA35385	1	SCHLEIFE
29	SA34499	1	SCHLEIFE
30	SA17490	1	SCHRAUBE * UNF 3/8X63,5
31	SA34589	1	LASCHE
32	SA17604	1	SCHRAUBE * (A) M5X9
33	SA36475	1	SCHUTZ
34	SA34452	4	SCHRAUBE * 6,0X14
35	SA36570	1	DECKEL
36	SA36481	1	DECKEL
37	SA34487	3	SCHRAUBE * K 60X14
38	SA36476	1	ABDECKUNG
39	SA36662	1	BLENDE
40	SA36512	1	ACHSE
41	SA36572	1	DREHFEDER
42	SA36569	2	LAGER
43	SA36516	1	PRALLSCHUTZ (A) WERDEN NUR NOCH IN PACKMENGEN GELIEFERT

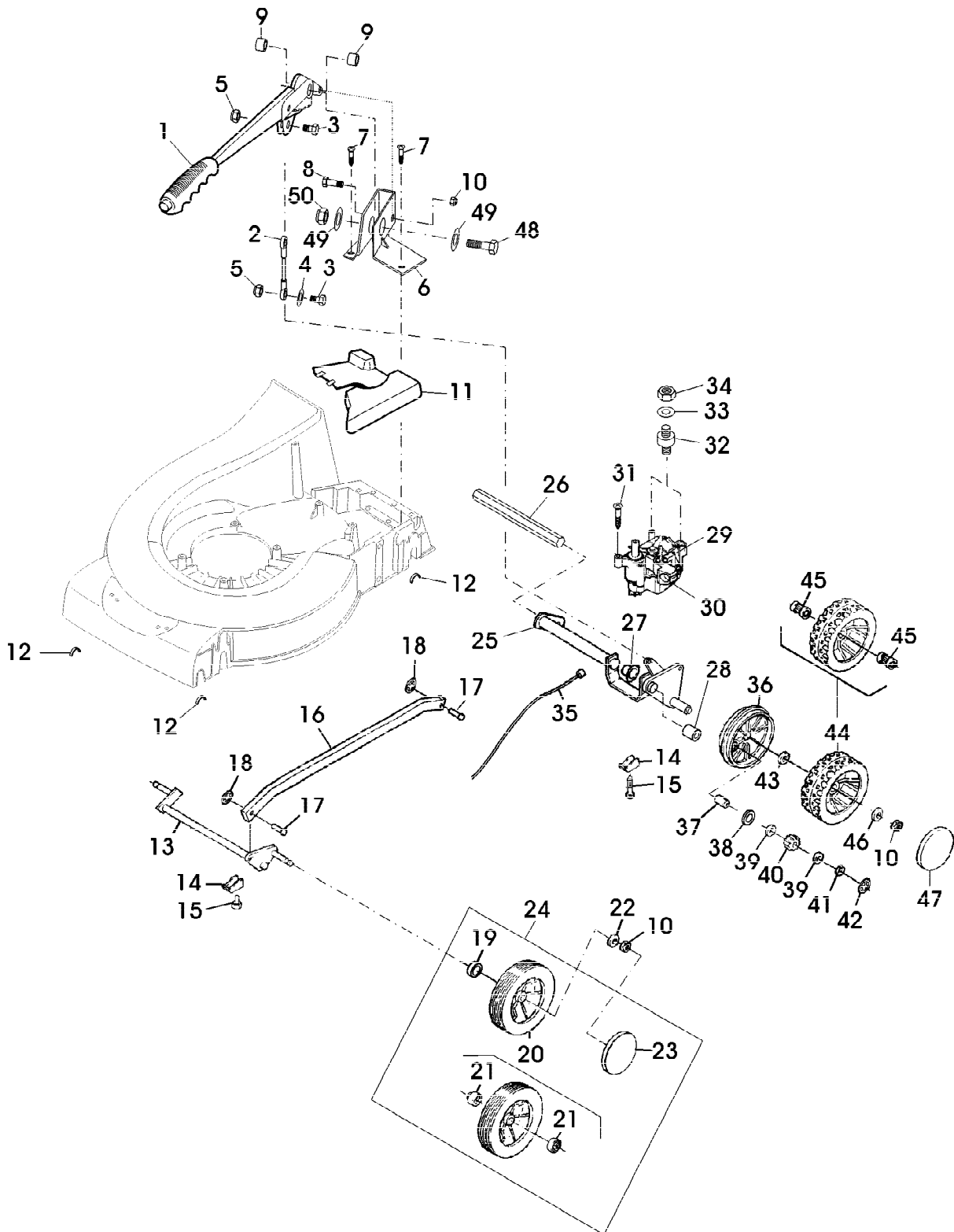

Reihennummer	Artikelnummer	Menge	Description
1	SA36499	1	HANDHEBEL ASSY INCL KEYS 48, 49, 50
2	SA36474	1	VERBINDUNGSSTANGE
3	SA15324	2	SECHSKANTSCHRAUBE M6X25
4	SA15202	1	UNTERLEGSCHIEBE 6,4
5	SA11244	2	SICHERUNGSMUTTER M6
6	SA36479	1	KONSOLE
7	SA34452	3	SCHRAUBE * DUO TAPTITE 6,0X14 CM
8	SA15365	1	SECHSKANTSCHRAUBE (A) M8X35
9	M112486	2	DISTANZSTUECK
10	SA11998	5	SICHERUNGSMUTTER (A) M8
11	SA36661	1	SCHUTZ (B)
12	SA31711	4	LAGERSCHALE
13	SA36477	1	VORDERACHSE FRONT
14	SA36261	4	KLEMME
15	SA29854	4	SCHRAUBE * (A) M 5X12
16	SA36484	1	VERBINDUNGSSTANGE
17	SA35588	2	BOLZEN
18	SA35589	2	FEDERKLEMME 8 SXN 59
19	SA35229	2	SCHEIBE
20	SA34392	2	RAD KPL. MIT BEREIFUNG (ORD SA35403) FRONT 180MM
21	SA33229	4	KUGELLAGER
22	SA15213	2	UNTERLEGSCHIEBE (A) A 8,4
23	SA36555	2	DECKEL FRONT
24	SA35403	2	RAD ASSY, FRONT 180MM
25	SA36478	1	HINTERACHSE REAR
26	SA36497	1	ANTRIEBSWELLE
27	SA34285	1	LAGER
28	SA31201	2	BUECHSE
29	SA34286	1	GETRIEBE
30	SA34279	1	FUEHRUNG
31	SA31264	1	SCHRAUBE * M5X16
32	SA36571	2	SCHWINGUNGSDAEMPFER
33	SA15232	2	FEDERRING A6
34	SA15412	2	MUTTER M6
35	SA36652	1	SEILZUG
36	SA36496	2	SCHUTZ
37	SA34284	2	MITNEHMER
38	SA13911	2	FEDERSCHIEBE (A)
39	SA13912	4	SCHEIBE (A)
40	SA34504	1	RITZEL LH
	SA34503	1	RITZEL RH
41	SA15864	2	SPRENGRING 14X1MM
42	SA34282	2	FEDERMUTTER 8
43	SA13926	1	SCHEIBE
44	SA36509	2	RAD KPL. MIT BEREIFUNG REAR 200MM
45	SA36659	4	NADELLAGER HK1616
46	SA16494	2	SCHEIBE
47	SA36508	2	DECKEL REAR
48	SA36697	1	STIFT
49	SA15207	2	UNTERLEGSCHIEBE A15
50	SA15694	1	SICHERUNGSMUTTER M10

---

Preisnummer	Artikelnummer	Menge	Description
			(A) WERDEN NUR NOCH IN PACKMENGEN GELIEFERT
			(B) VOR MONTAGE ENTLANG MARKIERUNG TRENNEN