

Ref #	Part #	<input checked="" type="checkbox"/> Description	<input checked="" type="checkbox"/> Qty	<input checked="" type="checkbox"/> Context Note	<input checked="" type="checkbox"/> Foot Note	<input checked="" type="checkbox"/> UOM
1	1502011E540MA Add to pick list	Frame, Motor Box				
2	15X143MA Add to pick list	Nut				
3	583459MA Add to pick list	Assembly, Bearing and Retainer				
4	580251MA Add to pick list	Retainer, Bearing				
5	43846MA Add to pick list	Bearing				
6	302628MA Add to pick list	Bolt				
7	338965MA Add to pick list	Pulley, Auger				
8	26X263MA Add to pick list	Screw				
9	762277MA Add to pick list	Cover, Left Belt				
10	1501927MA Add to pick list	Assembly, Auger Housing				
11	312300MA Add to pick list	Nut				
12	71067MA Add to pick list	Washer				
13	579052MA Add to pick list	Bolt				
14	55323MA Add to pick list	Blade, Scraper				
15	327072MA Add to pick list	Auger Assembly				
16	580969MA Add to pick list	Washer				
17	762278MA Add to pick list	Cover, Right				
18	12342MA Add to pick list	Screw				
19	302628MA Add to pick list	Screw				
20	577707MA Add to pick list	Rivet				

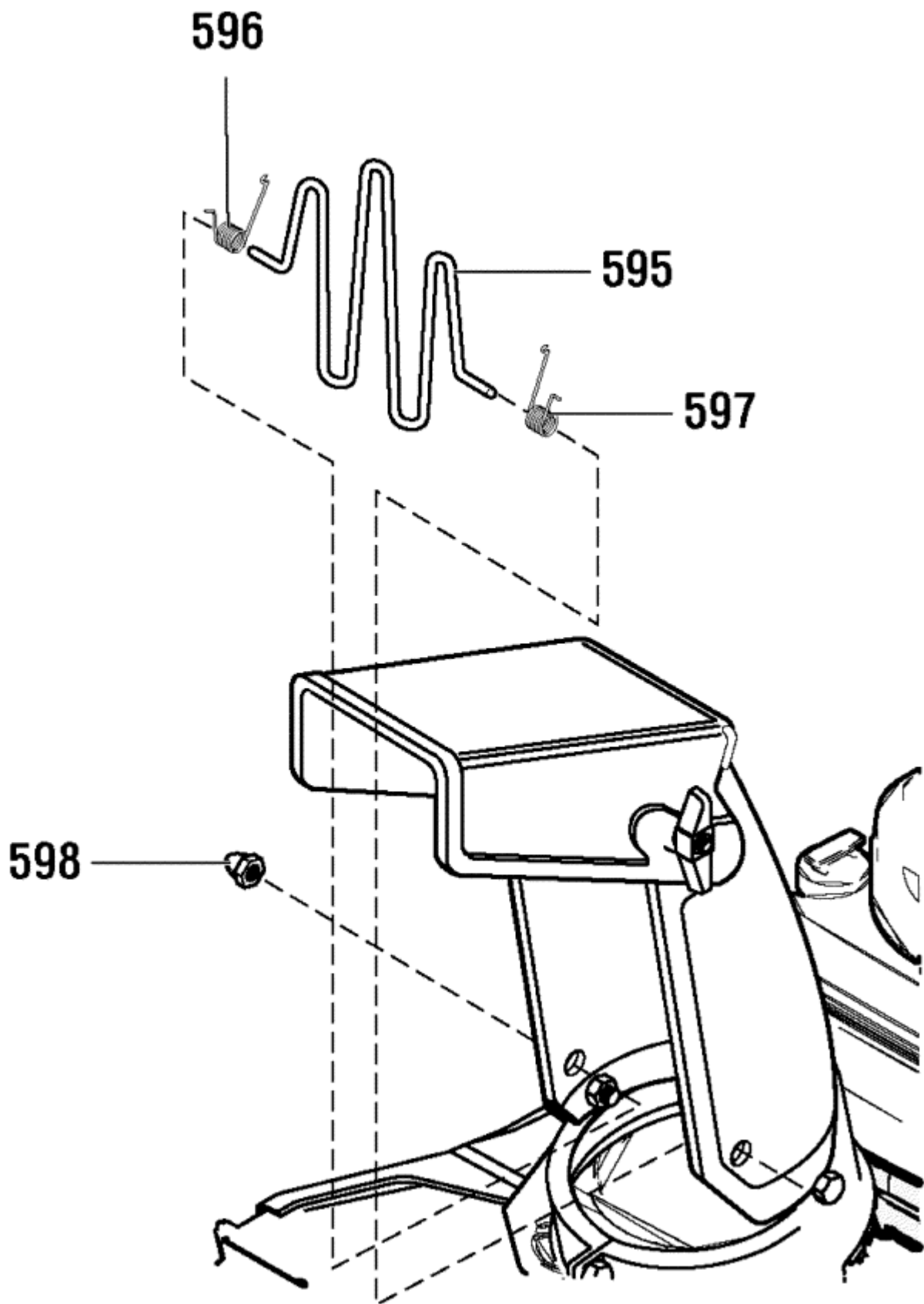

595	311206MA Add to pick list	GUARD, WIRE CHUTE				
596	51776MA Add to pick list	SPRING, TORSION				
597	51777MA Add to pick list	SPRING, TORSION				
598	49106MA Add to pick list	NUT, ACORN				

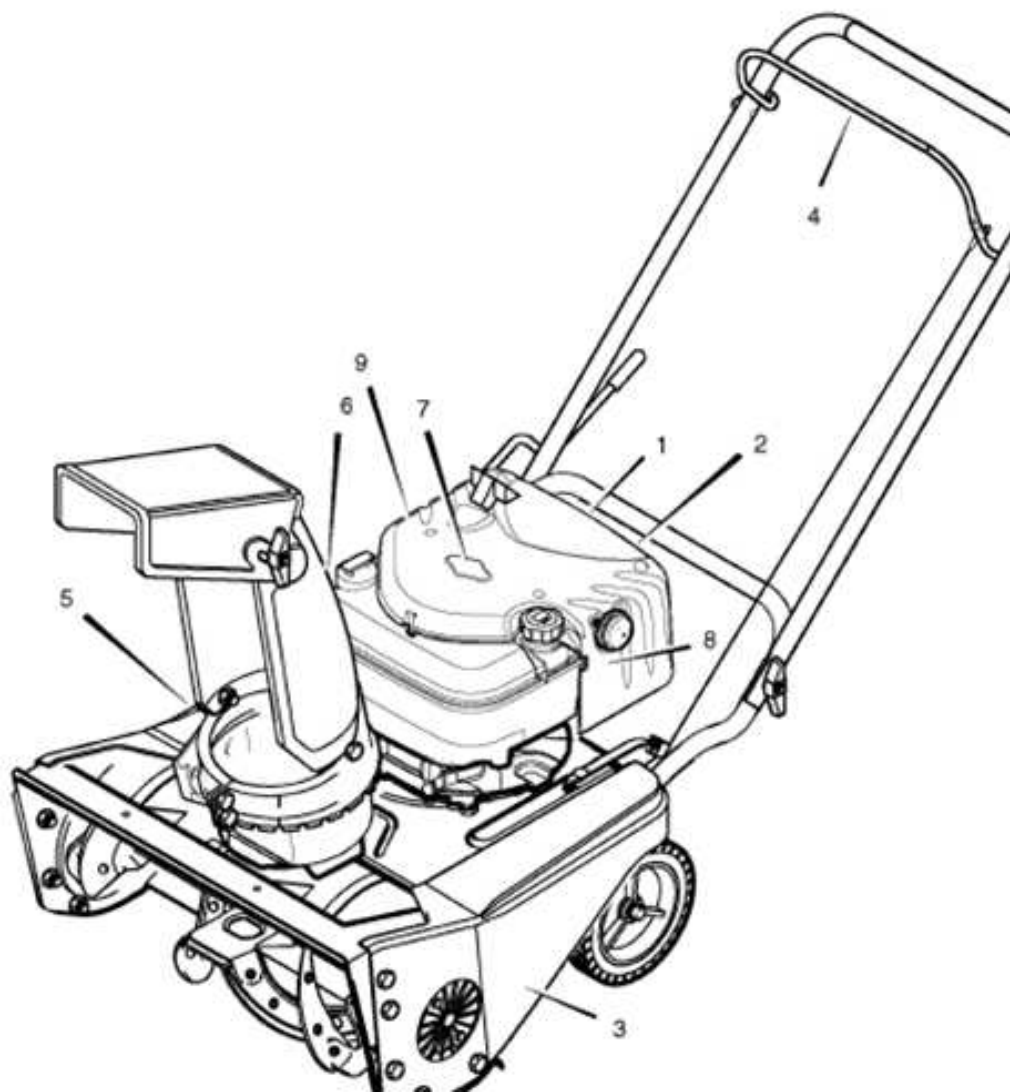

Ref #	Part #	<input checked="" type="checkbox"/> Description	<input checked="" type="checkbox"/> Qty	<input checked="" type="checkbox"/> Context Note	<input checked="" type="checkbox"/> Foot Note	<input checked="" type="checkbox"/> UOM
1	1741371MA Add to pick list	Decal, Murray Ultra 650/21 4hp / 21"				
2	48X5955MA Add to pick list	Decal, Choke				
3	48X304MA Add to pick list	Decal, Belt Instruction (inside cover)				
4	48X5998MA Add to pick list	Decal, Auger Control Lever				
5	48X5995MA Add to pick list	Decal, Danger Auger (Foot)				
6	48X5994MA Add to pick list	Decal, Danger Chute (Hand)				
7	48X5533MA Add to pick list	Decal, Briggs & Stratton				
8	48X5996MA Add to pick list	Decal, Primer Bulb				
9	48X5999MA Add to pick list	Decal, Hot Surface				

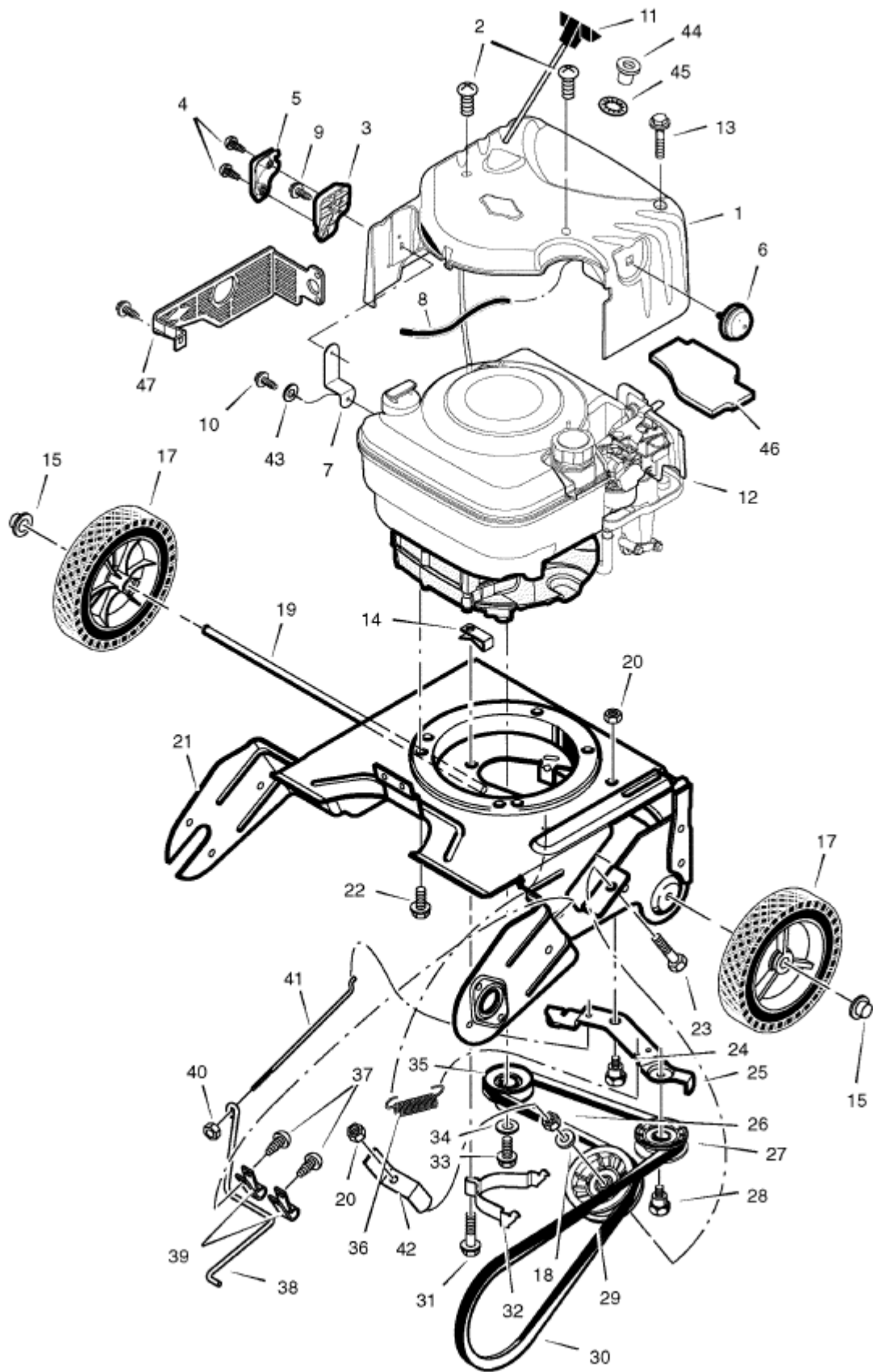

Supercessions	Ref #	Part #	Description	Qty	Context Note	Foot Note	UOM
	1	1501812MA Add to pick list	Cover, Top				
	2	26X316MA Add to pick list	Screw				
	3	1501814MA Add to pick list	Base, Chute Rod				
	4	26X292MA Add to pick list	Screw				
	5	1501815MA Add to pick list	Cover, Chute Rod				
	6	790221 Add to pick list	Primerbulb, Red				
	7	1501813MA Add to pick list	Bracket, Engine Chute				
	8	1259MA Add to pick list	Hose				
	9	780212MA Add to pick list	Screw				
	10	578408MA Add to pick list	Screw				
	11	1501724MA Add to pick list	Handle, Starter				
	12	----- Add to pick list	Engine		(1205020354E1)		
	13	01X215MA Add to pick list	Bolt				
	14	578109MA Add to pick list	Retainer				
	15	711627MA Add to pick list	Nut, Push Cap				
	17	760713MA Add to pick list	Wheel & Tire				
	18	71072MA Add to pick list	Washer				
	19	762280MA Add to pick list	Axle				
	20	71111MA Add to pick list	Nut				
	21	1502011E540MA Add to pick list	Frame, Motor Box				
	22	47792MA Add to pick list	Bolt				
	23	71007MA Add to pick list	Bolt				
	24	009X48MA Add to pick list	Bolt, Shoulder				
	25	762254MA Add to pick list	Bracket, Idler Arm				
	26	71044MA Add to pick list	Nut				
	27	762257MA Add to pick list	Pulley, V--Belt				

	28	762258MA Add to pick list	Bolt, Shoulder				
	29	762256MA Add to pick list	Pulley, Flat Idler				
	30	37X131MA Add to pick list	Belt				
	31	315312MA Add to pick list	Screw				
	32	762267MA Add to pick list	Guide, Belt				
	33	910828MA Add to pick list	Screw				
	34	71060MA Add to pick list	Washer				
	35	762255MA Add to pick list	Pulley				
	36	165X143MA Add to pick list	Spring				
	37	26X263MA Add to pick list	Screw				
	38	762288MA Add to pick list	Arm, Brake				
	39	762285MA Add to pick list	Clamp				
	40	312300MA Add to pick list	Nut				
	41	762287MA Add to pick list	Rod, Adjustment				
	42	762380MA Add to pick list	Guide, Belt				
	43	018X35MA Add to pick list	Lockwasher				
	44	1501919MA Add to pick list	Guide, Rope				
	45	028X84MA Add to pick list	Spring Grip Washer				
	46	1501920MA Add to pick list	Seal, Foam				
	47	1502130MA Add to pick list	Guard, Muffler				
	--	1740265 Add to pick list	Book, Instruction				

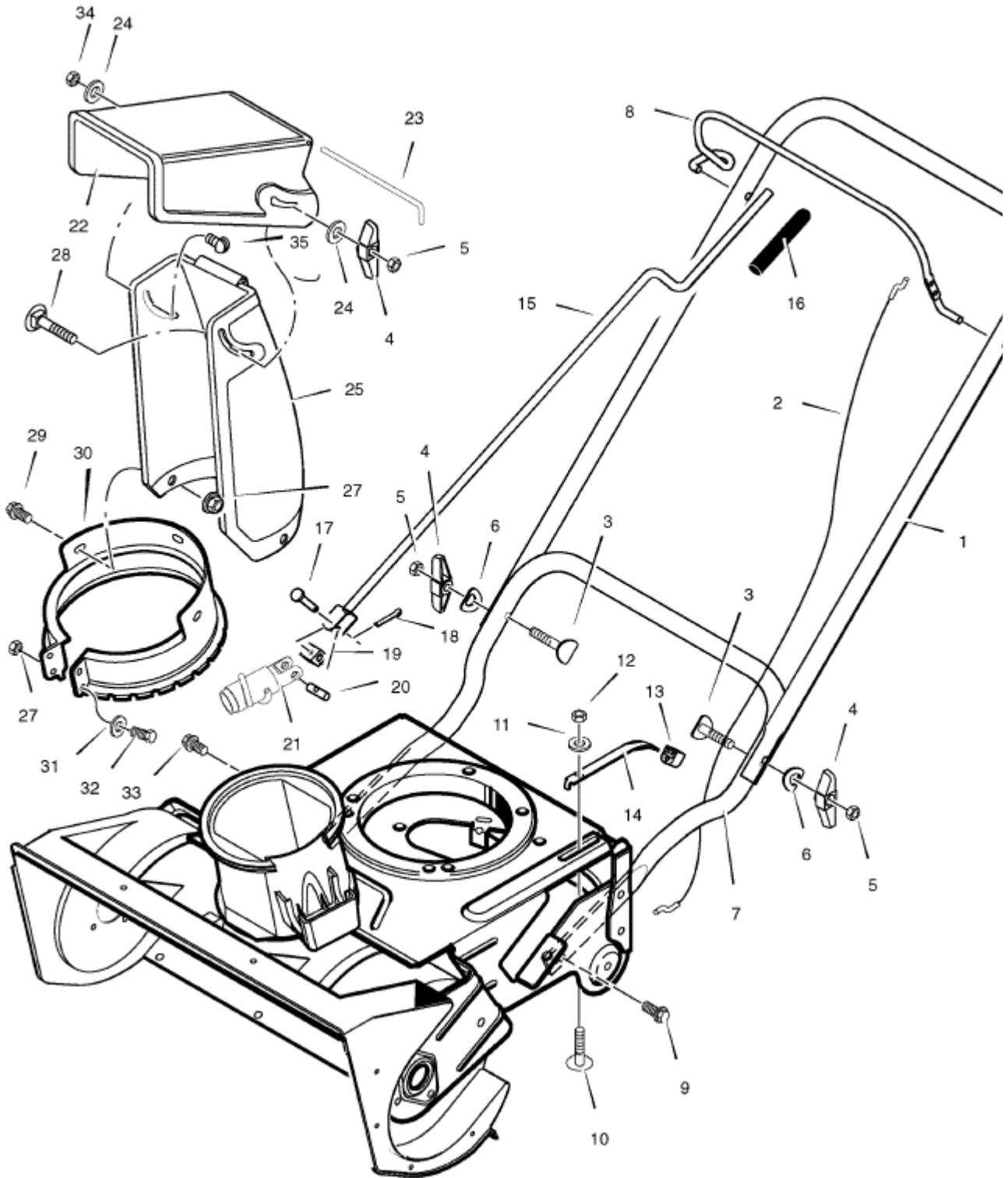

Supercessions	Ref #	Part #	<input checked="" type="checkbox"/> Description	<input checked="" type="checkbox"/> Qty	<input checked="" type="checkbox"/> Context Note	<input checked="" type="checkbox"/> Foot Note	<input checked="" type="checkbox"/> UOM
	1	762252E701MA Add to pick list	Handle, Upper				
	2	762259MA Add to pick list	Cable, Auger Drive				
	3	337584MA Add to pick list	Bolt				
↷	4	57171MA Add to pick list	Knob				
	5	71037MA Add to pick list	Nut				
	6	311936MA Add to pick list	Washer				
	7	762250E701MA Add to pick list	Handle, Lower				
	8	762251E701MA Add to pick list	Lever, Auger Drive				
↷	9	25X021MA Add to pick list	Screw				
	10	340715MA Add to pick list	Bolt				
	11	712123MA Add to pick list	Washer				
	12	780029MA Add to pick list	Nut				
	13	762281MA Add to pick list	Bushing, Tensioner				
	14	762282MA Add to pick list	Bracket, Cable Tensioner				
	15	762362MA Add to pick list	Rod, Crank				
	16	762289MA Add to pick list	Grip, Crank Rod				
↷	17	578309MA Add to pick list	Pin, Clevis				
↷	18	579493MA Add to pick list	Pin, Cotter				
	19	578063MA Add to pick list	Block, Universal Pivot				
↷	20	578060MA Add to pick list	Pin				
	21	585196MA Add to pick list	Gear, Worm				
	22	325847MA Add to pick list	Deflector				
	23	308931MA Add to pick list	Pin, Pivot				
↷	24	71071MA Add to pick list	Washer				
	25	334234MA Add to pick list	Chute, Discharge				
	27	15X143MA Add to pick list	Nut				

	28	302843MA Add to pick list	Bolt				
	29	313686MA Add to pick list	Bolt				
	30	1501846MA Add to pick list	Ring, Chute				
	31	71067MA Add to pick list	Washer				
	32	302628MA Add to pick list	Bolt				
	33	25X021MA Add to pick list	Bolt				
	34	71391MA Add to pick list	Locknut				
	35	578088MA Add to pick list	Bolt				