

NOTE: ALWAYS USE ORIGINAL EQUIPMENT PARTS. Use of service/replacement parts other than original equipment parts may void your warranty.

ALL UNNUMBERED ITEMS ARE INTERCHANGEABLE WITH OPPOSITE SIDE

344695A

# FRONT CHASSIS ASSEMBLY

KEY NO.	PART NO.	DESCRIPTION	QTY
1	95432-821	BRACKET, HOOD RH	1
2	95433-821	BRACKET, HOOD LH	1
3	711606	SCREW, 5/16-18X.75	4
4	94907	DASH	1
5	711762	SCREW, 1/4-14X.75	2
6	95195-821	HEAT SHIELD GUARD	1
7	712480	WASHER, FLAT .375X.87 INSULATE	2
8	302628	SCREW, 1/4-20X .75 HHC	2
9	71067	WASHER, FLAT .286X .63X.065	4
10	73826	NUT, 1/4-20 REGHEXCTRLK	2
11	341569-860	ASSEMBLY, LOWER CONSOLE	1
11-1	95425	TOWER, LOWER DASH	1
11-2	95426	SUPPORT, STEERING	1
11-3	710264	SCREW, 1/4-20X .50	4
11-4	95406	ROD, DASH BRACE	1
11-5	710264	SCREW, 1/4-20X .50	2
12	711606	SCREW, 5/16-18X.75	4
15	95270-860	PANEL, ACCESS	1
16	711629	SCREW, 10-24X.5	2
17	328278	HOOD	1
18	302670	LENS, HEADLAMP	1
19	308492	FOIL, LENS	1
21	301452	FOIL, HEAT REFLECTOR	6
22	711856	PIN, CLEVIS	2
23	711682	PIN, HAIR	2
24	6711	WASHER, PLASTIC .315X.75X.064	4
25	95404	BUSHING, STEERING SHAFT	1
	712467	OPERATOR'S MANUAL (NOT SHOWN)	

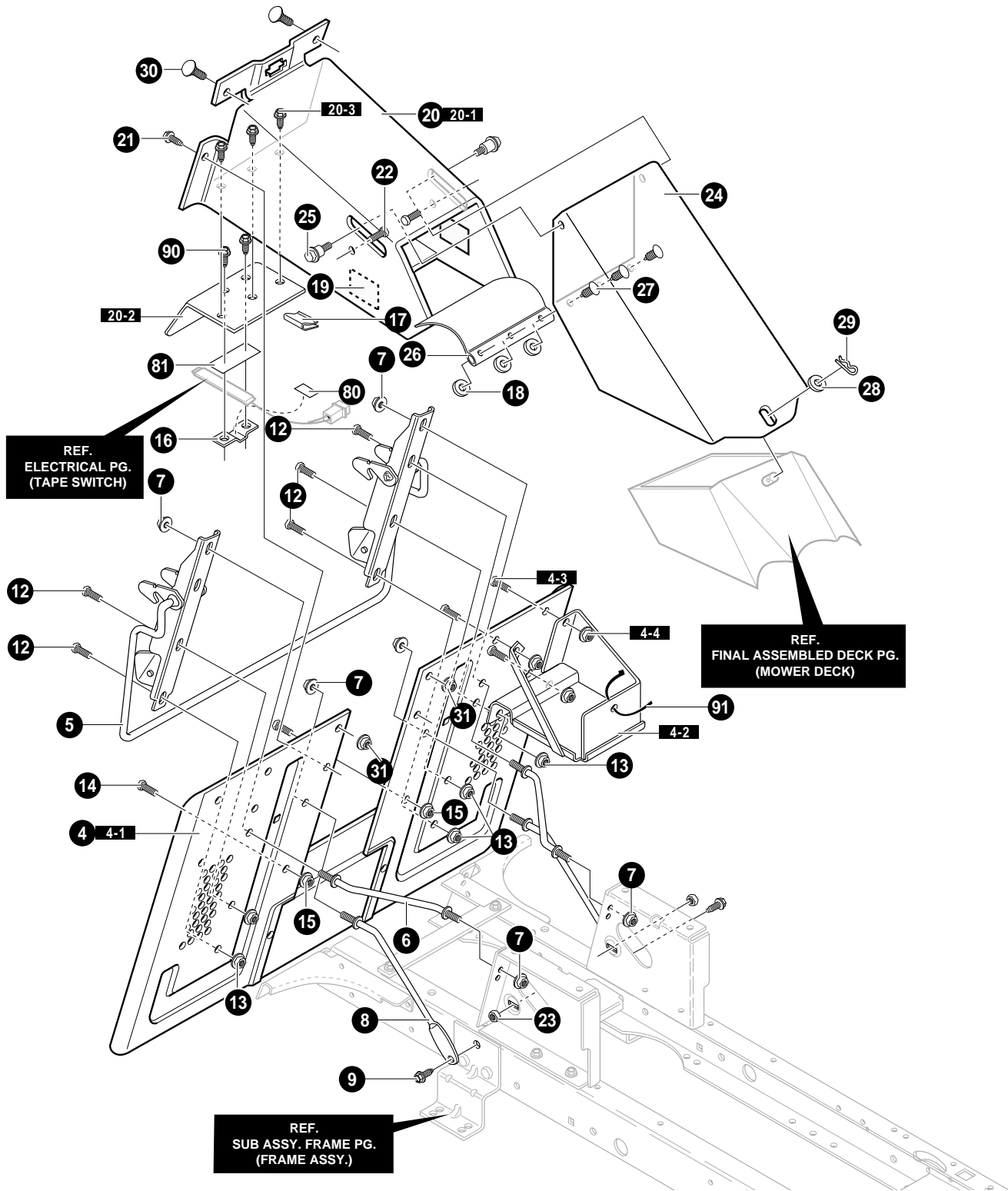

NOTE: ALWAYS USE ORIGINAL EQUIPMENT PARTS. Use of service/replacement parts other than original equipment parts may void your warranty.

ALL UNNUMBERED ITEMS ARE INTERCHANGEABLE WITH OPPOSITE SIDE

## REAR CHASSIS ASSEMBLY

KEY NO.	PART NO.	DESCRIPTION	QTY
4	343678-821	ASSY, BACK PLATE/BATTERY	1
4-1	95162	ASM. BACKPLATE FLAT	1
4-2	94563	BATTERY TRAY ASM.	1
4-3	180073	SCREW, 5/16-18X.50 HHC	3
4-4	45174	NUT, 5/16-18 HEXWDFLLK WHIZ	3
5	95359-821	WELDMENT-LATCH LEVER	1
6	690097	ROD, BRACE	2
7	711906	NUT, 3/8-16 HWDFL WHIZ-LOCK	5
8	94231	ROD, BRACE	2
9	711606	SCREW, 5/16-18X.75 HHWATAP	2
12	711907	SCREW 5/16-18X.75 HXWDFL	5
13	710026	NUT, 5/16-18 HEXWDFLLK WHIZ	5
14	711606	SCREW 5/16-18X.75 HHWATAP	2
15	710026	NUT, 5/16-18 HEXWDFLLK WHIZ	2
16	690245	BRACKET, FLEX SWITCH MOUNTING	1
17	55939	WIRE CLIP, ADHESIVE	1
18	711666	FLATWASHER, .250X.56X.047	3
19	318197	PAD, ADHESIVE 1.00X1.50X.12	2
20	690102-821	ASM., T/A SHIELD & UPPER CHUTE	1
20-1	94350	CHUTE WELD ASM. UPPER	1
20-2	95367	SHIELD, TRANSAXLE	1
20-3	711642	SCREW, 1/4-20X.63 HHWATAP	4
21	711606	SCREW, 5/16-18X.75 HHC	4
22	711688	BOLT, 5/16-18X.75 CARR	2
23	710026	NUT, 5/16-18 HEXWDFLLK WHIZ	2
24	94296-821	MIDDLE CHUTE ASSY	1
25	710440	BOLT, HSSH (9X57)	2
26	94264	FLAP, CHUTE	1
27	309235	FASTENER, RATCHET	3
28	711617	FLATWASHER	1
29	711682	PIN, HAIR .38DIAX1.64LG	1
30	711688	BOLT, 5/16-18X.75 CARR.	2
31	710026	NUT, 5/16-18 HXWDFLLK WHIZ	2
80	712009	TAPE, DOUBLE SIDED FOAM 3/4" WD	0.560 IN.
81	712009	TAPE, DOUBLE SIDED FOAM 3/4" WD	3 IN.
90	711642	SCREW, 1/4-20X.63 HHWATAP	2
91	57444	CABLE TIE	1

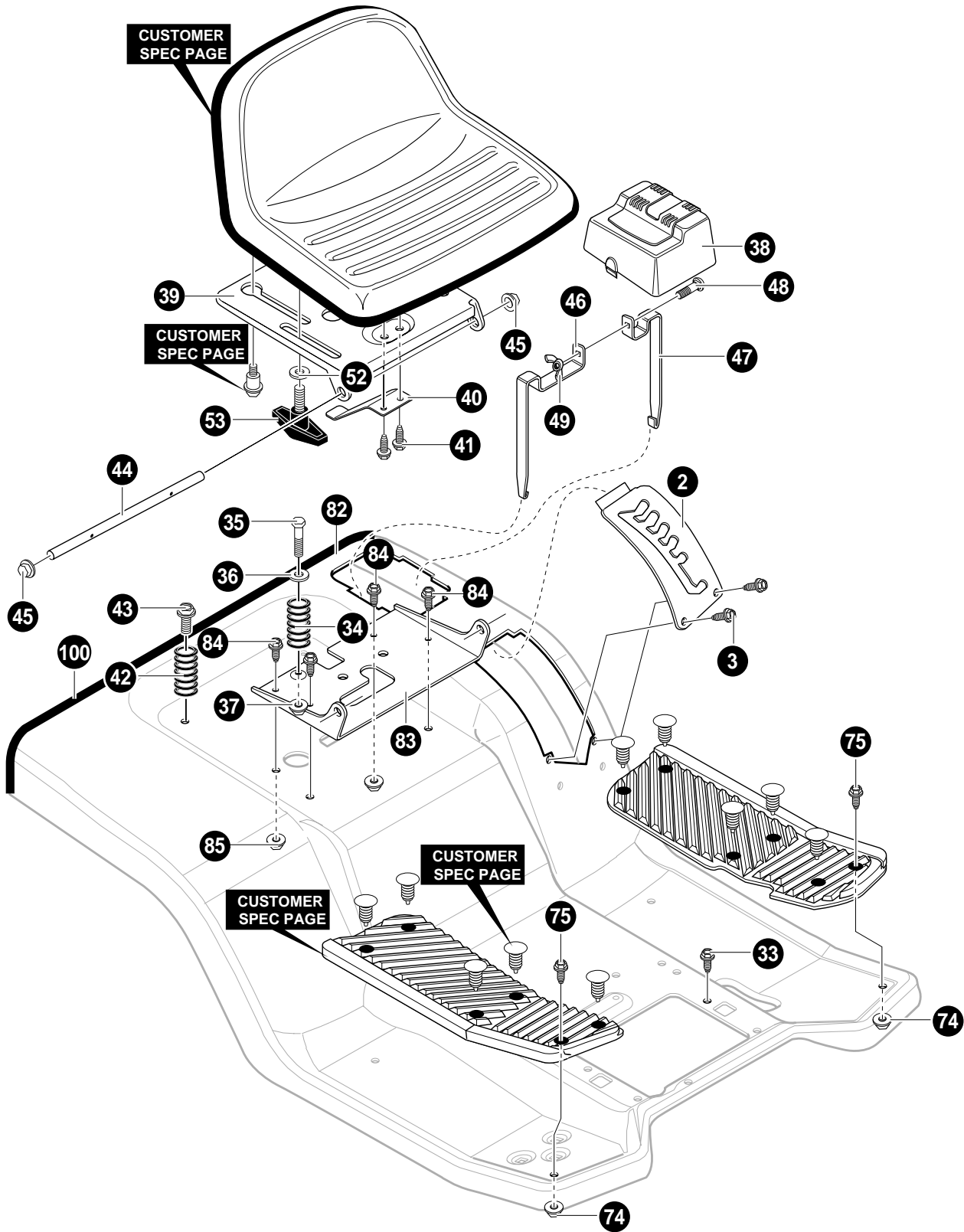

NOTE: ALWAYS USE ORIGINAL EQUIPMENT PARTS.  
Use of service/replacement parts other than original  
equipment parts may void your warranty.

ALL UNNUMBERED  
ITEMS ARE INTERCHANGEABLE  
WITH OPPOSITE SIDE

344862A

# REAR CHASSIS ASSEMBLY

KEY NO.	PART NO.	DESCRIPTION	QTY
2	95190-821	PLATE, LIFT DETENT	1
3	711741	SCREW, #12X.50 PHPNHTAP	2
33	711606	SCREW, 5/16-18X.75HHWATAP	1
34	710136	SPRING, COMPRESSION 4.57LGX1.17	1
35	711610	BOLT, SHOULDER 1/4-20	1
36	95293	ZINC WASHER CUP	1
37	302635	NUT, 1/4-20 CNTRLK	1
38	94200	COVER, BATTERY	1
39	94154-860	SUPPORT, SEAT	1
40	94057	SPRING-LEAF	1
41	711592	SCREW, 1/4-20X.50 WAHHTAP	2
42	710109	SPRING, COMPRESSION 2.43LG 164X30	2
43	711606	SCREW, 5/16-18X.75 HHWATAP	4
44	95294	ZINC HINGE SEAT PIVOT	1
45	711627	NUT, PUSH CAP .375	2
46	95393-821	BATTERY, BRACKET L.H.	1
47	95394-821	BATTERY, BRACKET R.H.	1
48	711680	BOLT, 1/4-20X.63 CARR.	1
49	711636	NUT, WING 1/4-20 14X79	1
52	711644	WASHER, FLAT .344X.62X.06	2
53	711747	BOLT, WING 5/16-18X.50	2
74	710026	NUT, 5/16-18 HEXWDFLLK WHIZ	2
75	711891	BOLT, 5/16-18X.7A5 CARR.	2
82	94204-860	ASM., SEAT DECK GEAR DRIVE	1
83	94153-860	BRACKET, PIVOT SEAT	1
84	711606	SCREW, 5/16-18X.75 HHWATAP	4
85	711634	NUT, 5/16-18 WDFLLK	2
100	779024	TRIM	26.8 IN.

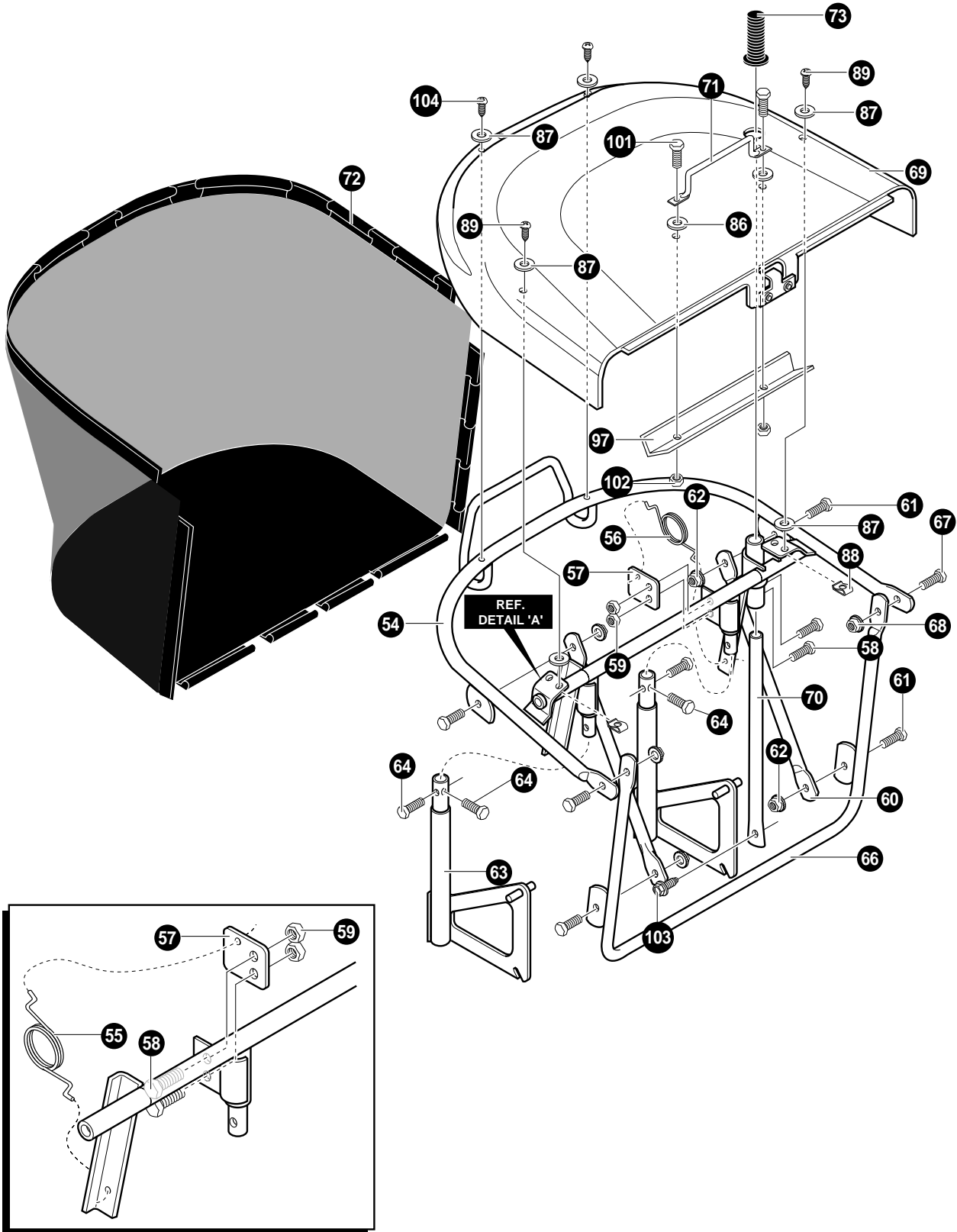

DETAIL 'A'

NOTE: ALWAYS USE ORIGINAL EQUIPMENT PARTS.  
Use of service/replacement parts other than original  
equipment parts may void your warranty.

ALL UNNUMBERED  
ITEMS ARE INTERCHANGEABLE  
WITH OPPOSITE SIDE

# REAR CHASSIS ASSEMBLY

KEY NO.	PART NO.	DESCRIPTION	QTY
54	690044-821	ASM. WELD UPPER FRAME	1
55	690003	SPRING, TORSION RH	1
56	690004	SPRING, TORSION LH	1
57	95339-821	BRACKET, SPRING COLLECTOR	2
58	313686	SCREW, 1/4-20X.50 HHC	4
59	73826	NUT, 1/4-20 REGHEXCTRLK	4
60	94850-821	BRACE, FRAME COLLECTOR	2
61	711909	SCREW, 1/4-20X.62 HHC	4
62	711632	NUT, 1/4-20HEXNYL	4
63	95343-821	WELD ASM., SUPPORT COLLECTOR	2
64	711653	SCREW, 5/16-18X1.50	4
66	95349-821	WELD ASM., FRONT FRAME COLLECT.	1
67	711909	SCREW, 1/4-20X.62 HHC	2
68	711632	NUT, 1/4-20 HEXNYL	2
69	94908-860	TOP COLLECTOR ASM.	1
70	690019	HANDLE, DUMP COLLECTOR	1
71	94855-821	HANDLE, REBA COLLECTOR	1
72	95389	REBA COLLECTOR BAG	1
73	94854	RUBBER GRIP	1
86	712129	WASHER, .281X1.25X.06	2
87	711921	WASHER, .328X1.06X.062	6
88	578107	NUT, 1/4-20 TINN U	2
89	711674	SCREW, 1/4-20X.63 PHPNHD	2
97	690010-821	BRACE, BAGGER	1
101	712068	SCREW 1/4-20X1.50 PHPNHD	2
102	711632	NUT, 1/4-20 HEXNYL	2
103	711741	SCREW, #12X.50 PHPNHTAP	1
104	711741	SCREW, #12X.50 PHPNHTAP	2



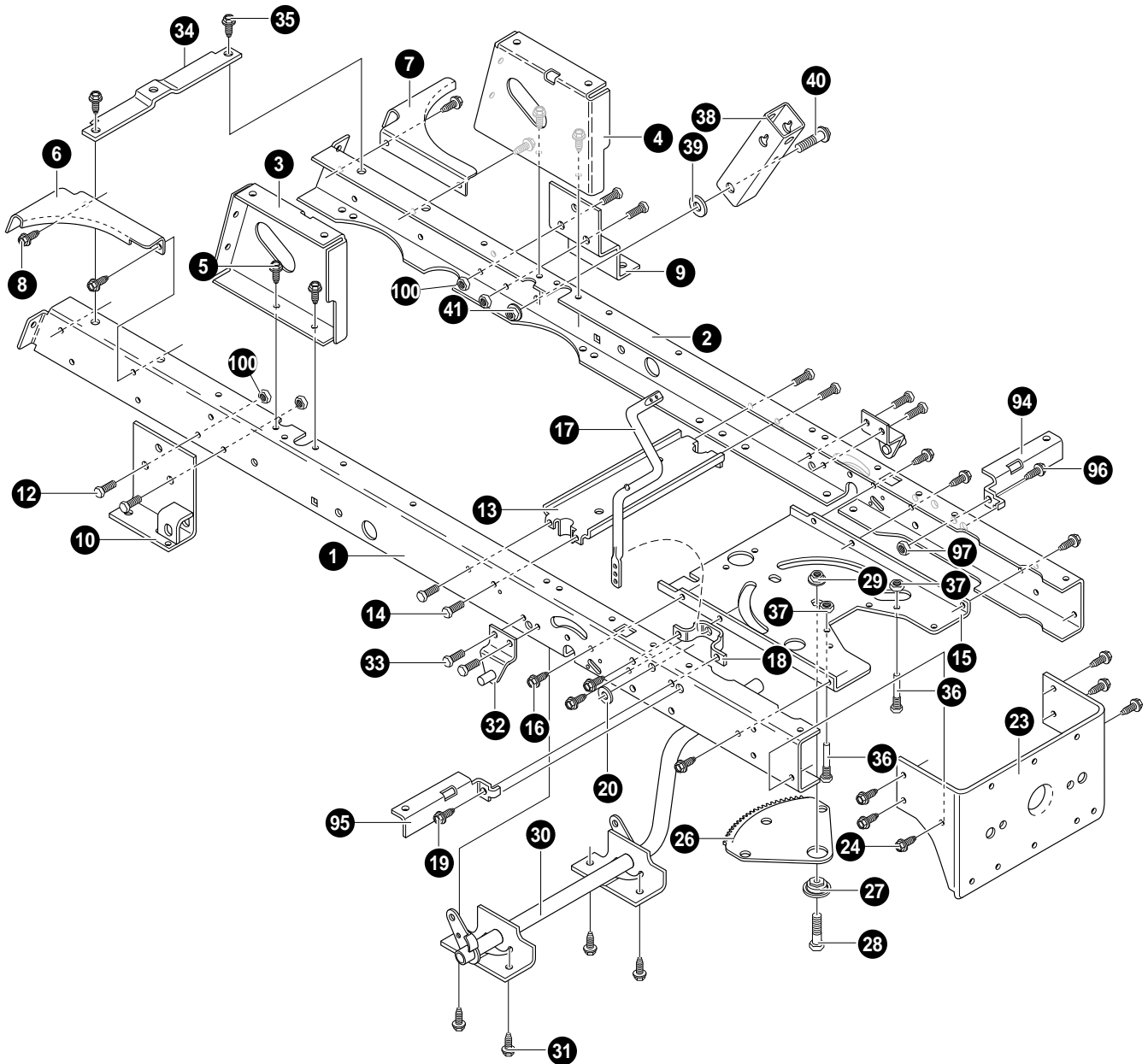

NOTE: ALWAYS USE ORIGINAL EQUIPMENT PARTS.  
Use of service/replacement parts other than original equipment parts may void your warranty.

ALL UNNUMBERED  
ITEMS ARE INTERCHANGEABLE  
WITH OPPOSITE SIDE

# FRAME ASSEMBLY

KEY NO.	PART NO.	DESCRIPTION	QTY
1	94564	FRAME, RAIL RH	1
2	94565	FRAME, RAIL LH	1
3	94634	SUPPORT, SEAT RH	1
4	94633	SUPPORT, SEAT LH	1
5	710079	SCREW 5/16-18X.75 HHWATAP	4
6	94561	BRACE, BACKPLATE RH	1
7	94562	BRACE, BACKPLATE LH	1
8	710079	SCREW 5/16-18X.75 HHWATAP	4
9	94234	BRACKET, TRANSAXLE	1
10	95396	WELD, ASSY SHIFT BRACE LEVER	1
12	710079	SCREW, 5/16-18X.75 HHWATAP	4
13	94237	ASM. IDLER MOUNT, FRONT	1
14	710079	SCREW, 5/16-18X.75 HHWATAP	4
15	690504	PLATE, STEERING	1
16	710079	SCREW, 5/16-18X.75 HHWATAP	6
17	94019	CRANK, PTO	1
18	94005	BRACKET, BELL CRANK	1
19	710079	SCREW, 5/16-18X.75 HHWATAP	2
20	120395	WASHER, FLAT .469X.92X.065	1
23	94013	BRACKET, HANGER REAR	1
24	710079	SCREW, 5/16-18X.75HHWATAP	6
26	94121	GEAR, SECTOR	1
27	94123	BEARING, SECTOR GEAR	1
28	710312	SCREW, 5/16-18X1.00	1
29	710105	NUT, 5/16-18 HEXKEPS 15X113	1
30	94241	ASM., CLUTCH/BRAKE PEDAL	1
31	710079	SCREW, 5/16-18X.75 HHWATAP	4
32	94285	BRACKET, SUSPENSIONASM.	2
33	710079	SCREW, 5/16-18X.75 HHWATAP	4
34	94566	BRACE, RAIL	1
35	710079	SCREW, 5/16-18X.75 HHWATAP	2
36	93349	ZINC SCREW GUIDE	2
37	710204	NUT, 5/16-18 HEXWDFLLK WHIZ	2
38	94015	BRACKET, PIVOT	1
39	845	WASHER, FLAT .390X1.25X.119	1
40	710000	BOLT, .562X1.563 HSH 3/8-16	1
41	710140	NUT, 3/8-16 HWDFLLK MACK 15X84	1
94	690036	BRACKET -SEAT DECK LH	1
95	690035	BRACKET-SEAT DECK RH	1
96	710079	SCREW, 5/16-18X.75 HHWATAP	1
97	710204	NUT, 5/16-18 HEXWDFLLK WHIZ	1
100	710205	NUT, 5/16-18 WDFLLK	4

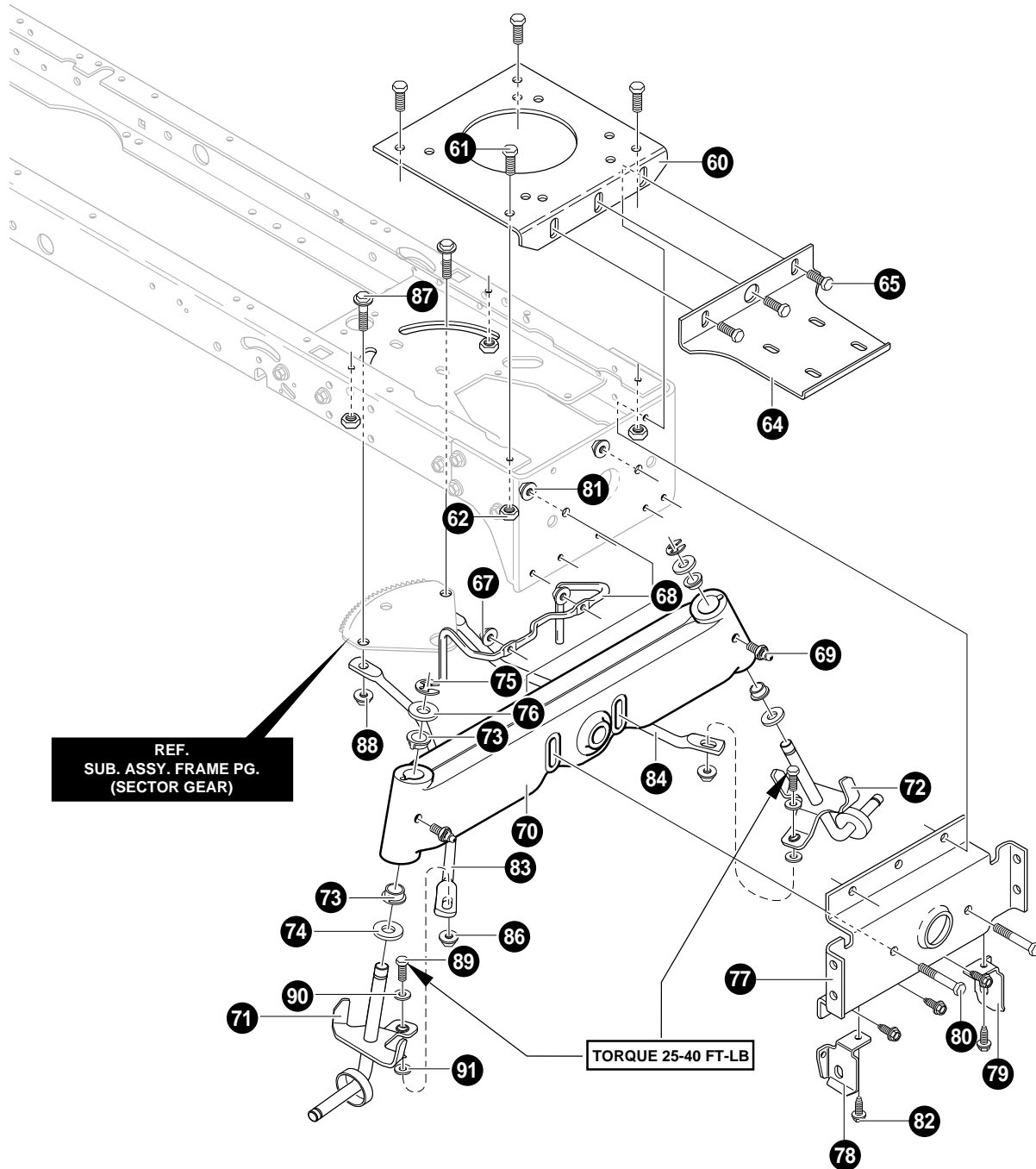

NOTE: ALWAYS USE ORIGINAL EQUIPMENT PARTS.  
Use of service/replacement parts other than original equipment parts may void your warranty.

ALL UNNUMBERED  
ITEMS ARE INTERCHANGEABLE  
WITH OPPOSITE SIDE

343659B

# FRAME ASSEMBLY

KEY NO.	PART NO.	DESCRIPTION	QTY
60	94006	ENGINE PLATE	1
61	710079	SCREW, 5/16-18X.75 HHWATAP	4
62	710205	NUT, 5/16-18 WDFLLK 15X88	4
64	94901	BRACKET, MUFFLER MOUNT	1
65	710079	SCREW, 5/16-18X.75 HHWATAP	3
67	45174	NUT, 5/16-18 HEXWDFLLK WHIZ	2
68	94310	GUIDE-STACK PULLEY BELT	1
69	706	ZERK, GREASE FITTING	2
70	95405	AXLE, CAST MACHINED REBA	1
71	95182	SPINDLE, LONG RH	1
72	95183	SPINDLE, LONG LH	1
73	92527	BEARING, SPINDLE	4
74	710129	WASHER, .766IDX1.62ID	2
75	710103	E-RING .574IDX.050X.750SH 11X3	2
76	710088	WASHER, FLAT .765X1.81X.059	2
77	94007	HANGER, AXLE	1
78	690199	HANGER, DECK RH	1
79	690198	HANGER, DECK LH	1
80	180113	SCREW, 5/16-18X3.00	2
81	710205	NUT, 5/16-18 WDFLLK 15X88	2
82	710079	SCREW, 5/16-18X.75 HHWATAP	5
83	95328	DRAG LINK RH	1
84	95329	DRAG LINK LH	1
86	710140	NUT, 3/8-16 HWDFFLLK MACK 15X84	2
87	710440	SHOULDER BOLT 9X57	2
88	710140	NUT, 3/8-16 HWDFFLLK MACK 15X84	2
89	710082	SCREW, 3/8-16X1.5	2
90	710083	WASHER FLAT .391X1.00X.083	2
91	710142	WASHER FLAT .406X.81X16GA	2

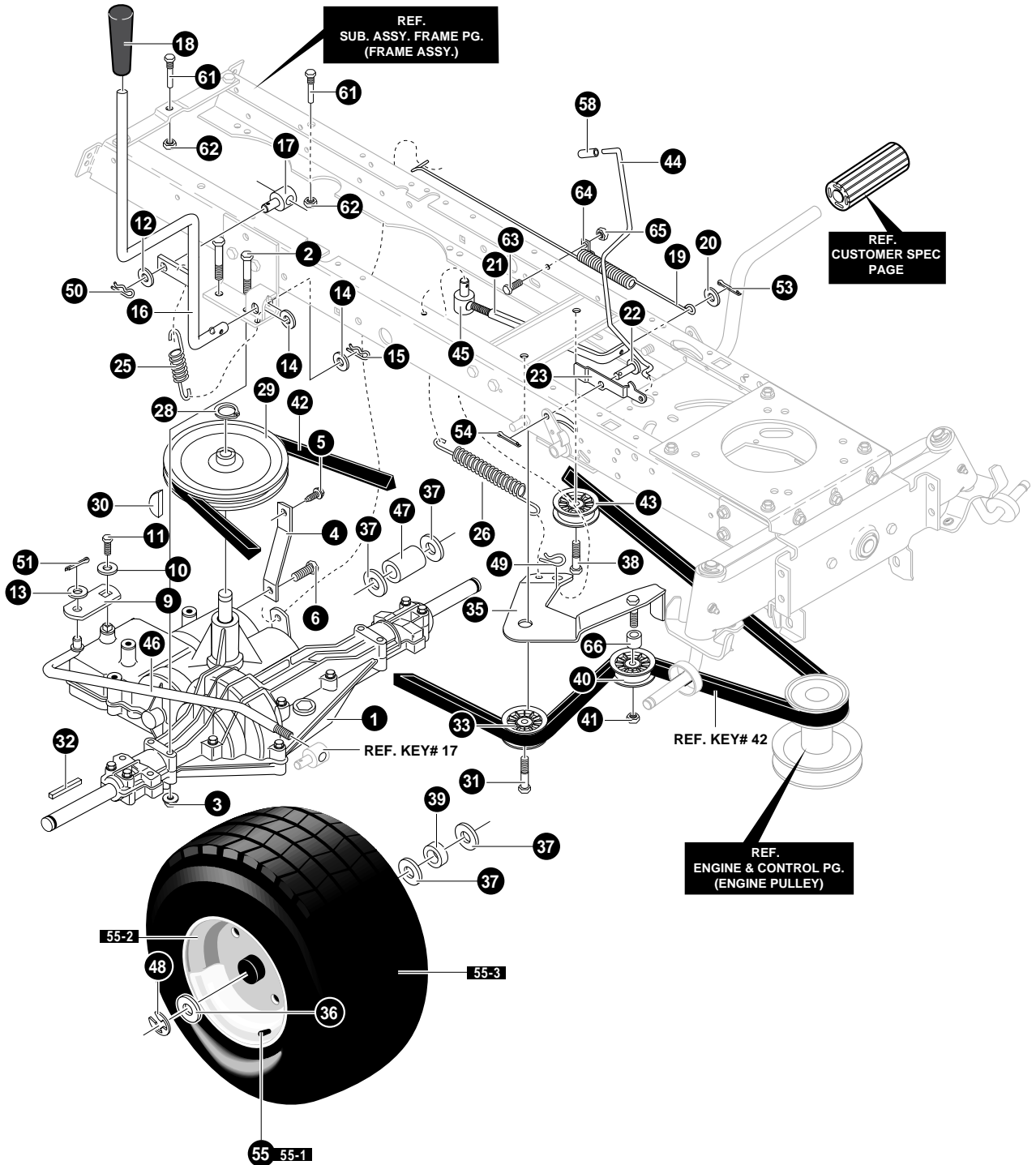

NOTE: ALWAYS USE ORIGINAL EQUIPMENT PARTS. Use of service/replacement parts other than original equipment parts may void your warranty.

ALL UNNUMBERED ITEMS ARE INTERCHANGEABLE WITH OPPOSITE SIDE

# MOTION DRIVE ASSEMBLY

KEY NO.	PART NO.	DESCRIPTION	QTY
1	*	TRANSAXLE MST206-512A	1
2	711669	SCREW, 5/16-18X2.50	4
3	711634	NUT, 5/16-18 WDFLLK	4
4	94620-821	BRACKET,STABILIZER	1
5	711606	SCREW, 5/16-18X.75	1
6	710268	SCREW, 5/16-18X.75 WAHHTAP	1
9	94227	BRACKET,SHIFT	1
10	711895	WASHER,.750X.250 TRANSAXLE	1
11	710345	SCREW,1/4-28X.75	1
12	583409	WASHER, FLAT .391X1.00X.125	1
13	71072	WASHER, FLAT .406X .81X.066	1
14	711894	WASHER, FLAT .515X .88X.064	2
15	711899	PIN, HAIR .53DIA X1.62LG	1
16	690087	SHIFT LEVER	1
17	711591	NUT, ADJ. 3/8-16	1
18	94929	GRIP, LIFT 1/2"	1
19	95424	SPRING, BRAKE	1
20	711921	WASHER, FLAT.328X1.06X.062	1
21	690016	ROD, CLUTCH	1
22	711903	PIN, CLEVIS	1
25	35410	SPRING	1
26	711522	SPRING, TENSION	1
28	710340	RING, RETEX	1
29	94571	PULLEY, 9.0 OD V4L	1
30	50795	KEY, HI-PRO 606	1
31	711905	SCREW, 3/8-16X1.25	1
32	52928	KEY, SQUARE	2
33	95531	PULLEY, IDLER	1
35	94238-821	ASSY, IDLER ARM TRACTION	1
36	711758	WASHER, FLAT .765X1.81X.059	2
37	711904	WASHER, FLAT .755ID	4
38	711905	SCREW, 3/8-16X1.25	1
39	95418	SPACER, WHEEL	1
40	690409	PULLEY, IDLER 2.75 DIA	1
41	711920	NUT, 3/8-16 HWDFLLK	1
42	94608	BELT, V 4L 114.12	1
43	95531	PULLEY, IDLER V4L3.00X.710	1
44	690046	PARK BRAKE CONTROL ROD	1
45	711898	NUT, 5/16-18X3/8 ADJUSTING	1
46	690027	ROD, SHIFT LINK	1
47	95419	SPACER, .87 X 2.25	1
48	710103	E-RING .574IDX.050/.75	2
49	711659	PIN, HAIR .072DIA X1.13LG	1
50	711682	PIN,HAIR.38 DIA X1.64LG	1
51	71081	PIN, COTTER .094 DIA X .75	1
53	71081	PIN, COTTER .094 DIA X .75	1
54	71081	PIN, COTTER .094 DIA X .75	1
55	692511	TIRE & RIM	2
55-1	338512	VALVE STEM	1
55-2	338524	RIM, CARL	1
55-3	338525	TIRE, 20X8X8	1
58	335980	CAP, DUMP VALVE ROD	1
61	20619	SCREW GUIDE	2
62	710026	NUT, 5/16-18 HEXWDFLLK WHIZ	2
63	313686	SCREW, 1/4-20X .50	1
64	711742	RETAINER, WIRE	1
65	780285	NUT, 1/4-20 WDFLWHIZ-LK	1
66	690369	SPACER, 1/2 TO 17MM	1

\* CONTACT YOUR NEAREST TRANSAXLE DEALER FOR PARTS AND SERVICE.

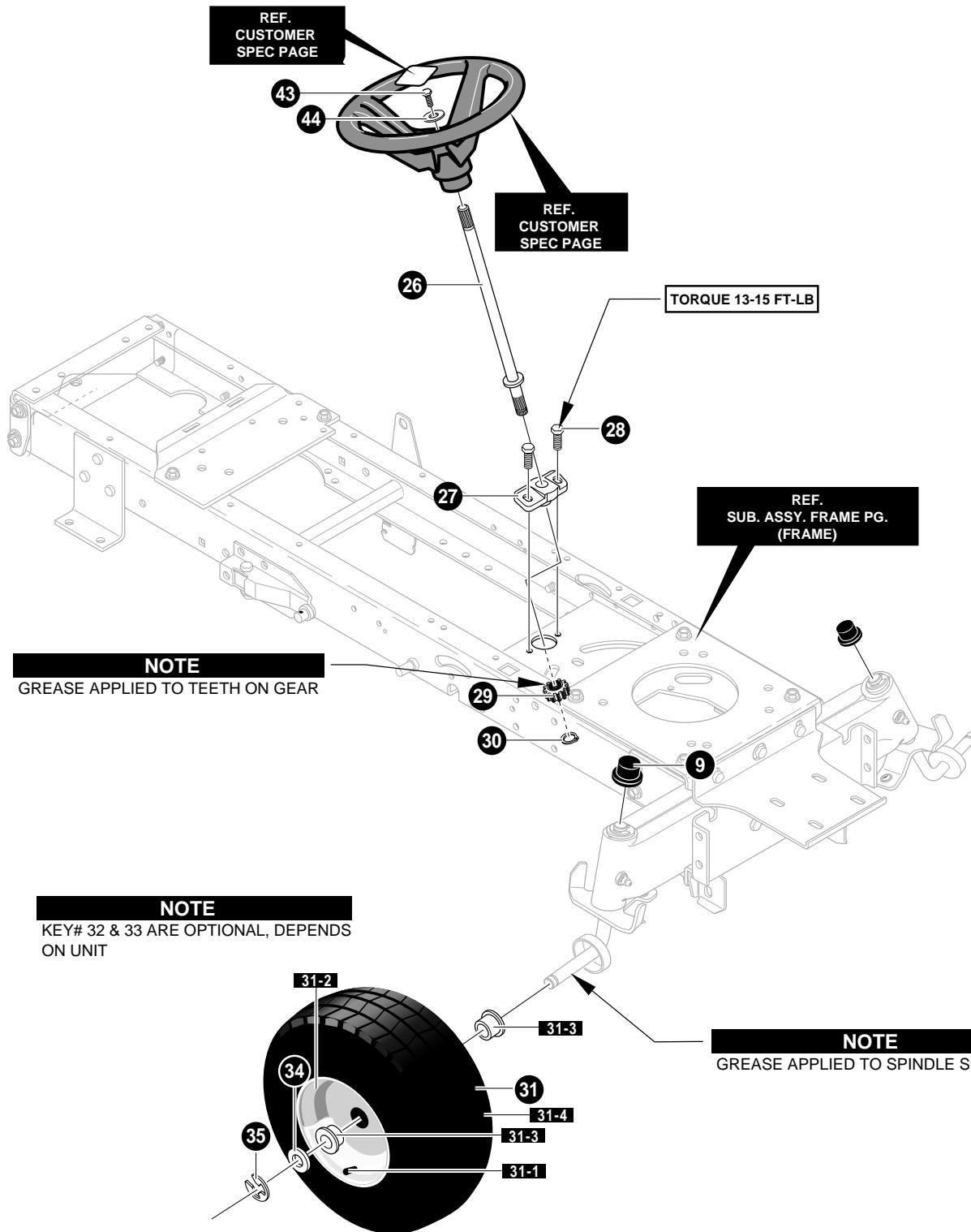

NOTE: ALWAYS USE ORIGINAL EQUIPMENT PARTS. Use of service/replacement parts other than original equipment parts may void your warranty .

ALL UNNUMBERED ITEMS ARE INTERCHANGEABLE WITH OPPOSITE SIDE

344861A

# STEERING ASSEMBLY

KEY NO.	PART NO.	DESCRIPTION	QTY
9	94618	DUST HUB CAP	2
26	94520	SHAFT, STEERING	1
27	94124	BEARING-LOWER	1
28	711606	SCREW, 5/16-18X.75	2
29	94122	GEAR PINNION	1
30	710102	RING, RET E.	1
31	692287	TIRE&RIM, 15X6.0-6	2
31-1	338512	VALVE STEM	1
31-2	338517	RIM	1
31-3	338513	BEARING	1
31-4	338514	TIRE, 15X6X6	1
34	711758	WASHER, FLAT .765X1.81X.059	2
35	710103	E-RING	2
43	711719	SCRW, 1/4-20X.75 HHC	1
44	711663	WASHER, FLAT .281X1.25X.06	1



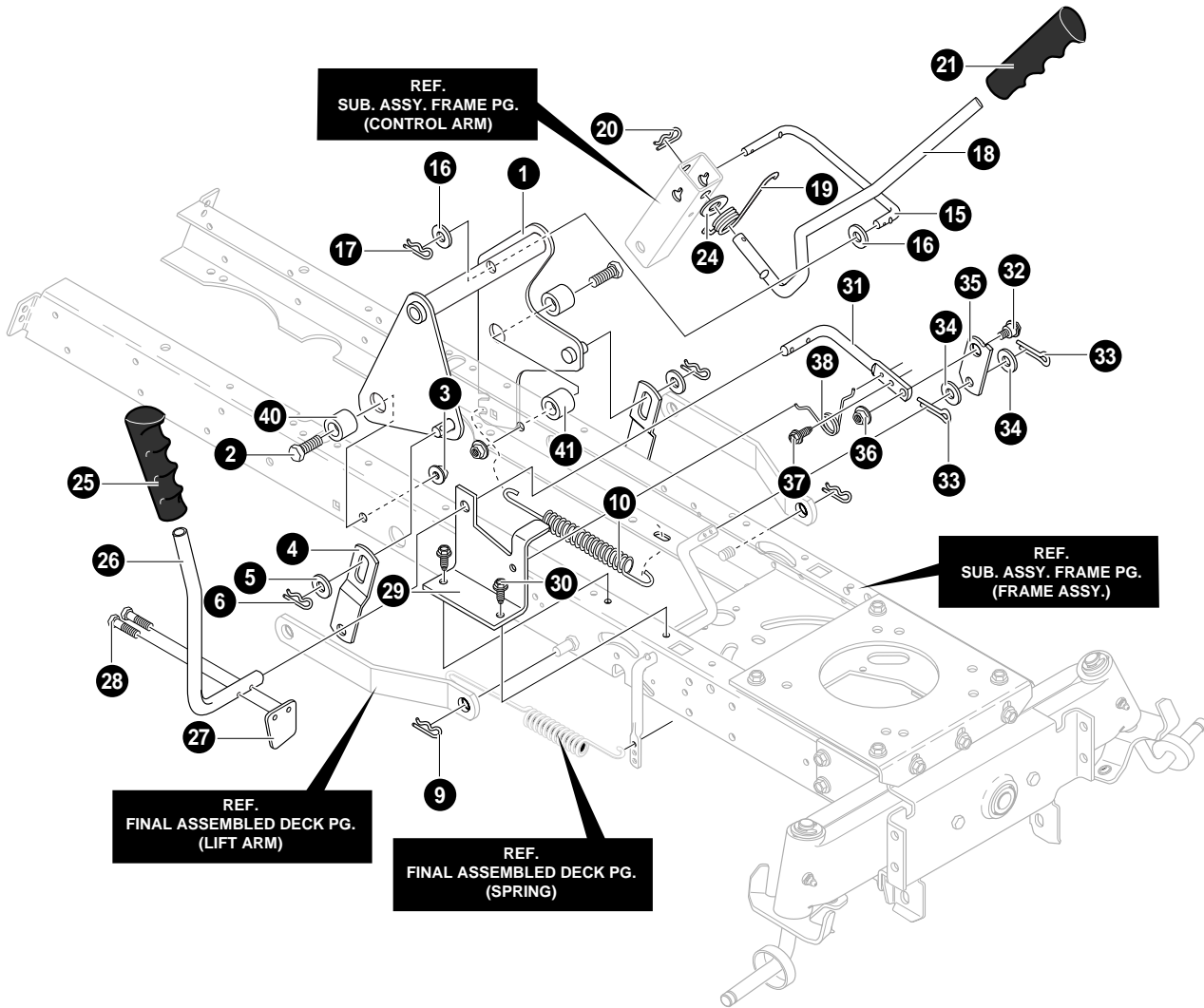

NOTE: ALWAYS USE ORIGINAL EQUIPMENT PARTS.  
 Use of service/replacement parts other than original  
 equipment parts may void your warranty.

ALL UNNUMBERED  
 ITEMS ARE INTERCHANGEABLE  
 WITH OPPOSITE SIDE

344419A

## MOWER SUSPENSION ASSEMBLY

KEY NO.	PART NO.	DESCRIPTION	QTY
1	95233-821	ASSEMBLY, LIFT ARM	1
2	711917	SCREW, 1/2-13X1.50	2
3	711918	NUT, 1/2-13 LOCK	2
4	94262-821	BRACKET, LIFT LINK	2
5	711617	WASHER, FLAT	2
6	711676	PIN, HAIR	2
9	711676	PIN, HAIR	2
10	710235	SPRING, EXTENSION 9.82X1.01 OD	1
15	711981	LINK - LIFT HANDLE	1
16	711617	WASHER, FLAT	2
17	711676	PIN, HAIR	1
18	95296	HANDLE, LIFT	1
19	710111	TORSION SPRING	1
20	711676	PIN, HAIR	1
21	94929	GRIP, LIFT	1
24	711616	WASHER, FLAT .550X1.00X11	1
25	94928	GRIP	1
26	690126	PTO HANDLE	1
27	95284	ZINC PADDLE, SWITCH	1
28	711621	SCREW, THREAD FORM	2
29	94018-821	BRACKET, PTO	1
30	780055	SCREW, 5/16-18X.50	2
31	95283	ZINC LEVER, PTO	1
32	711613	BOLT, .50X.75 HSSH 3/8-16	1
33	711659	PIN, HAIR	2
34	711615	WASHER, FLAT .518X.87X16	2
35	95282	ZINC LINK PTO	1
36	711622	NUT, 3/8-16 HWD FLLK MACK	1
37	711606	SCREW, 5/16-18X.75	1
38	710141	TORSION SPRING	1
40	94309	SPACER	2
41	56150	SPACER, SLEEVE	1

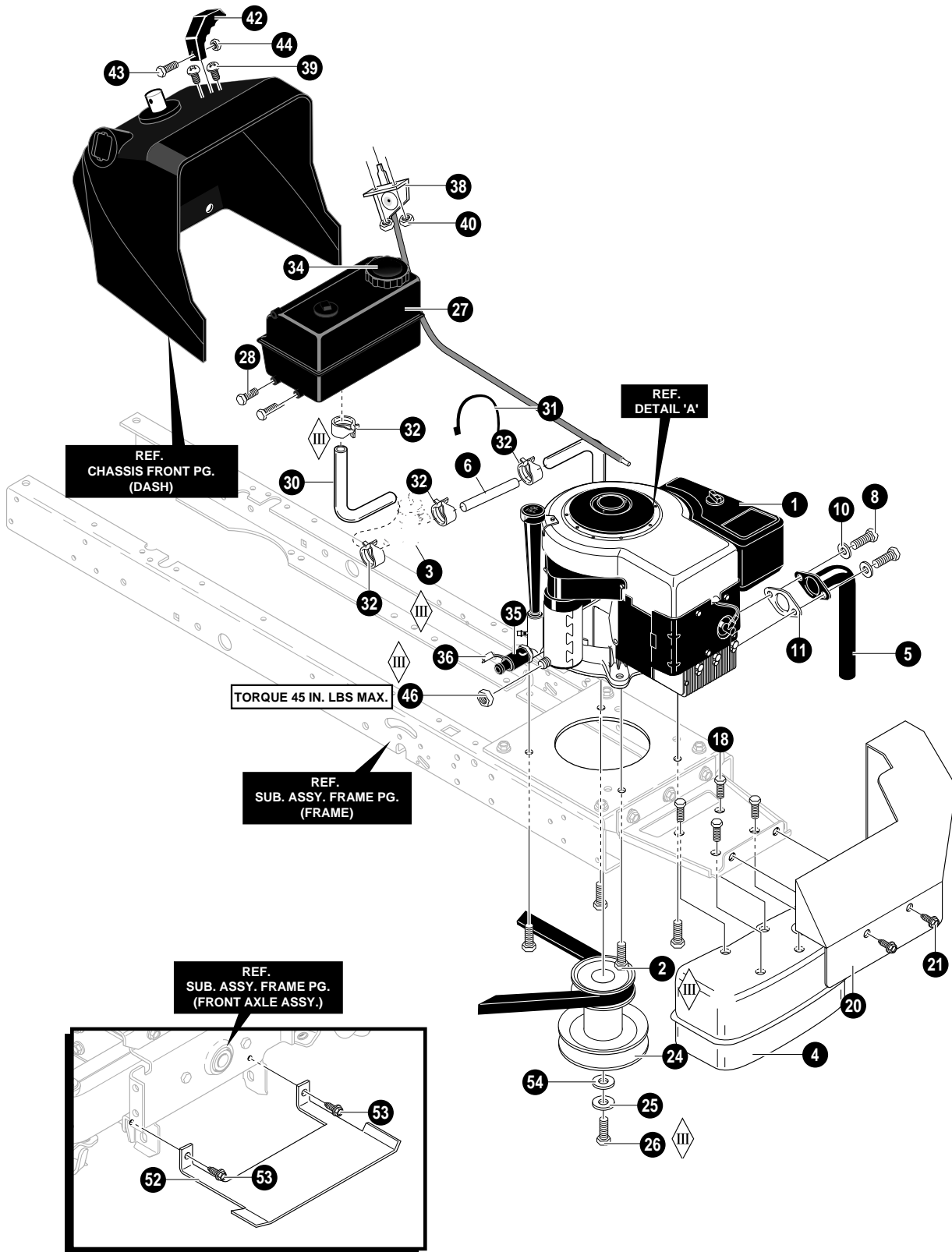

NOTE: ALWAYS USE ORIGINAL EQUIPMENT PARTS. Use of service/replacement parts other than original equipment parts may void your warranty.

ALL UNNUMBERED ITEMS ARE INTERCHANGEABLE WITH OPPOSITE SIDE

344947B

## ENGINE & CONTROL ASSEMBLY

KEY NO.	PART NO.	DESCRIPTION	QTY
1	*	ENGINE, 12.5HP	1
2	710199	SCREW, 3/8-16X1.25	4
3	690494	FUEL SHUT OFF	1
4	94902	MUFFLER	1
5	94900	EXHAUST PIPE	1
6	309306	TUBING	3.250 IN.
8	313676	SCREW, 5/16-18X .75	2
10	313679	WASHER, HVSP TLK	2
11	91309	GASKET, MUFFLER	1
18	711642	SCREW, 1/4-20X .63 HHWATAP	4
20	94904-821	HEAT SHIELD	1
21	711606	SCREW, 5/16-18X.75	2
24	690456	STACK PULLEY ASSY	1
25	120383	WASHER, REGSPTLK	1
26	710248	SCREW, 7/16-20	1
27	309853	TANK, FUEL	1
28	711681	SCREW, 15TPIX .	4
30	48252	TUBING, .25X.50X BULK GAS	8 IN.
31	57444	TIE, CABLE BLACK	1
32	336890	CLAMP,HOSE SCREW TYPE	4
34	12501	CAP,FUEL	1
35	325547	OIL DRAIN VALVE ASSEMBLY	1
36	327422	CAP, OIL DRAIN VALVE	1
38	95370	THROTTLE CONTROL 22"	1
39	711755	SCREW, 10-24X.63	2
40	711754	NUT, #10-24 HXHDNYLK	2
42	94931	KNOB,THROTTLE CONTROL	1
43	711750	SCREW, #8-32X .38	1
44	711748	NUT, #8-32 REGHEX	1
46	711601	NUT, 1/4-20 REGHEXJAM	1
52	95192	SHIELD, ANTI DEHYDRATION DEFLEC	1
53	711606	SCREW, 5/16-18X.75 HHWATAP	2
54	710247	WASHER, FLAT .480X1.00X.25	1

\* SEE ENGINE MANUAL

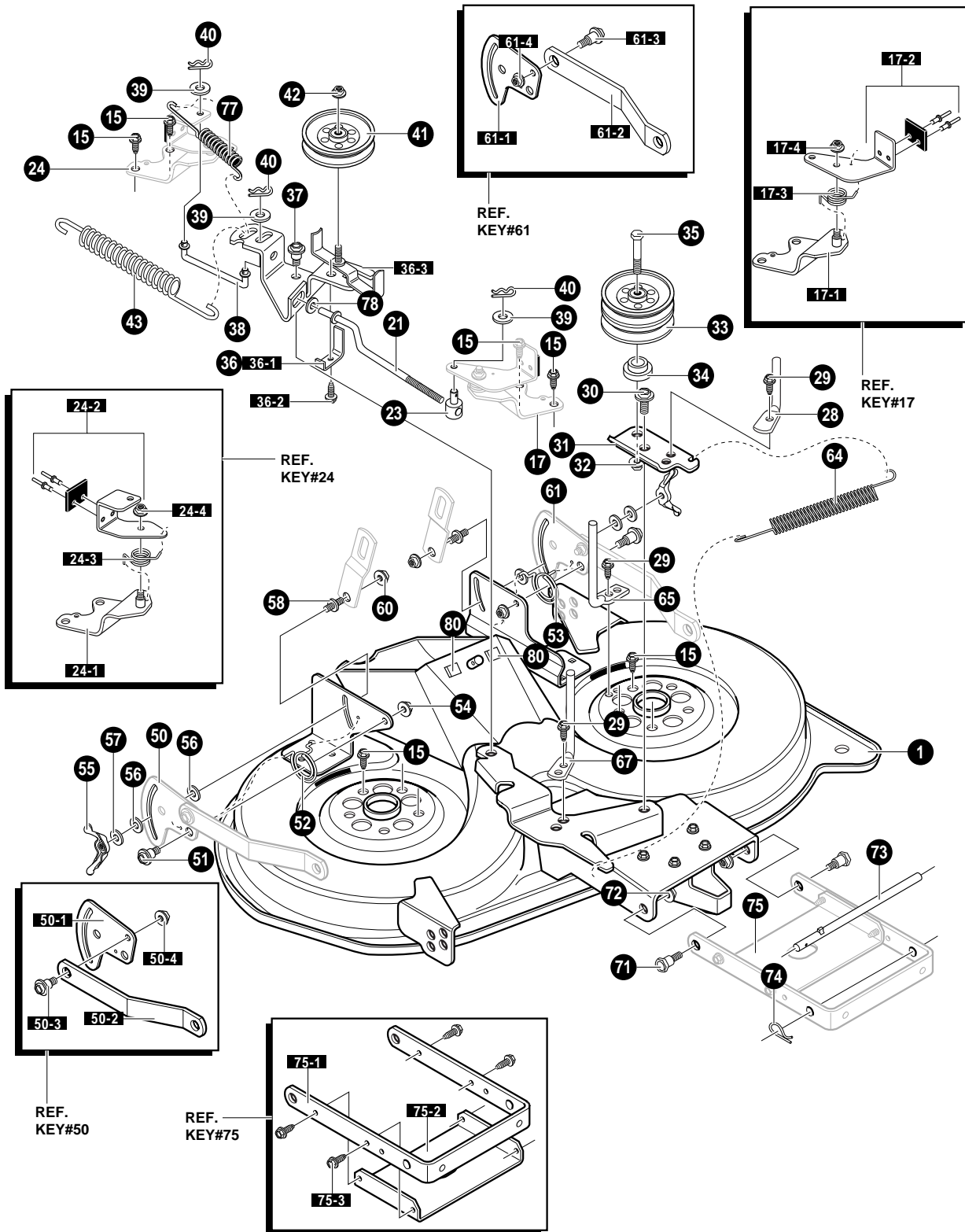

NOTE: ALWAYS USE ORIGINAL EQUIPMENT PARTS. Use of service/replacement parts other than original equipment parts may void your warranty .

ALL UNNUMBERED ITEMS ARE INTERCHANGEABLE WITH OPPOSITE SIDE

# DECK ASSEMBLY

KEY NO.	PART NO.	DESCRIPTION	QTY
1	690109-821	HOUSING, 40" DECK	1
17	94665-821	BRAKE ARM ASSEMBLY LH	1
17-1	94293	BRAKE SUPPORT ASSEMBLY LH	1
17-2	94291	BRAKE ARM ASSEMBLY LH	1
17-3	710110	SPRING, TORSION	1
17-4	710205	NUT, 5/16-18	1
21	690021	LINK, BRAKE LH	1
23	711591	NUT, ADJUST	1
24	94664-821	BRAKE ARM ASSEMBLY RH	1
24-1	94294	BRAKE SUPPORT ASSEMBLY RH	1
24-2	94292	BRAKE ARM ASSEMBLY RH	1
24-3	710077	SPRING, TORSION	1
24-4	710205	NUT, 5/16-18	1
28	711912	GUIDE, BELT	1
29	711914	SCREW,5/16-18 X .50	3
30	711613	BOLT, SHOULDER	1
31	94261-821	ARM, DOUBLE IDLER	1
32	711622	NUT, 3/8-16	1
33	94279	PULLEY, IDLER DOUBLE VEE	1
34	94269	SPACER	1
35	711915	SCREW, 3/8-16X3.00	1
36	94973-821	IDLER ARM ASSY	1
36-1	94312	SPRING - GUIDE BELT	1
36-2	710264	SCREW, 1/4-20X .50	1
36-3	94298	IDLER ARM ASSEMBLY	1
37	711613	BOLT., SHOULDER	1
38	690023	LINK, BRAKE RH	1
39	712480	WASHER, FLAT INSULATE	3
40	711682	PIN, HAIR	3
41	690024	PULLEY, V IDLER 4"	1
42	711622	NUT, 3/8-16	1
43	710234	SPRING, EXTENSION	1
50	690158-821	ASSEMBLY, PLATE, REAR SUS. BRKT. RH	1
50-1	94128	PLATE - SUSPENSION	1
50-2	94055	SUSPENSION BRACKET REAR'	1
50-3	710095	BOLT, SHOULDER	1
50-4	710140	NUT, 3/8-16	1
51	711611	BOLT, SHOULDER	2
52	710112	SPRING, TORSION RH	1
53	710113	SPRING, TORSION LH	1
54	711622	NUT, 3/8-16	2
55	711600	WINGNUT, 5/16-18	2
56	94137	PAD, FRICTION	4
57	711628	WASHER	2
58	711595	PIN, HANGER	2
60	711622	NUT, 3/8-16	2
61	690159-821	ASSEMBLY, PLATE, REAR SUS. BRKT. LH	1
61-1	94128	PLATE - SUSPENSION	1
61-2	94055	SUSPENSION BRACKET, REAR	1
61-3	710095	BOLT, SHOULDER 3/8-16	1
61-4	710140	NUT, 3/8-16	1
64	710233	SPRING, EXTENSION	1
65	711913	GUIDE, BELT	1
67	690030	GUIDE, BELT	1
71	711611	BOLT, SHOULDER	2
72	711622	NUT, 3/8-16	2
73	95295	ROD, HANGER	1
74	711676	PIN, HAIR	1
75	690058-821	ASSEMBLY, BRACKET & STIFFENER	1
75-1	94058	BRACKET, FRONT SUSPENSION	1
75-2	95057	STIFFENER	1
75-3	710079	SCREW, 5/16-18X.75	4
77	710658	SPRING, EXTENSION	1
78	712480	WASHER, FLAT	1
80	318197	PAD, ADHESIVE 1.00X1.50X.12	2

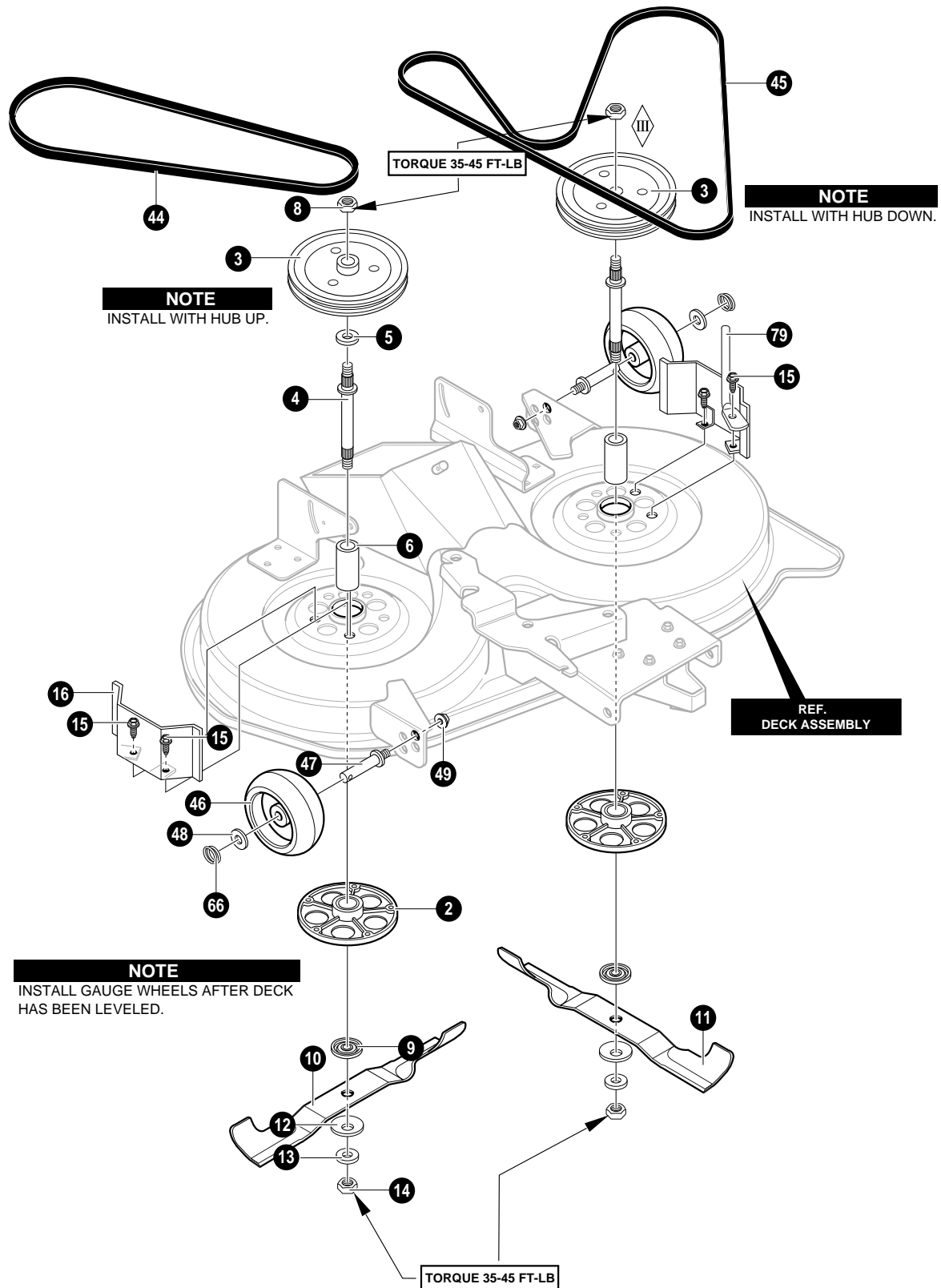

NOTE: ALWAYS USE ORIGINAL EQUIPMENT PARTS. Use of service/replacement parts other than original equipment parts may void your warranty.

ALL UNNUMBERED ITEMS ARE INTERCHANGEABLE WITH OPPOSITE SIDE

344276A

# DECK ASSEMBLY

KEY NO.	PART NO.	DESCRIPTION	QTY
2	94305	ASSEMBLY, JACKSHAFT HOUSING	2
3	690020	PULLEY, DECK	2
4	91922	JACKSHAFT	2
5	710117	WASHER, FLAT	1
6	91903	SPACER, .625X.875X1.91	2
8	711910	NUT, 9/16-18	2
9	94207	ADAPTER, DECK/BLADE 40"	2
10	690499	BLADE, LH REBA HI-LIFT	1
11	690500	BLADE, RH REBA HI-LIFT	1
12	710118	WASHER, BELLVILLE	2
13	710117	WASHER, FLAT	2
14	711910	NUT, 9/16-18	2
15	711911	SCREW, 3/8-16X1.00	10
16	94288-821	COVER PULLEY	2
44	710231	BELT, V 46.5LG	1
45	690071	BELT, DECK	1
46	92683	GAUGE WHEEL	2
47	711746	BOLT, SHOULDER	2
48	711615	WASHER, FLAT	2
49	711622	NUT, 3/8-16	2
66	711764	PIN, CIRCLE	2
79	95280	ROD, BELT GUIDE	1





# ELECTRICAL ASSEMBLY

KEY NO.	PART NO.	DESCRIPTION	QTY
1	95378	WIRE HARNESS	1
2	690054	INDICATOR HARNESS	1
3	95381	REAR HARNESS	1
4	94103	WIRE HARNESS FOR HEADLIGHTS	1
5	52572	BULB, HEADLAMP	2
6	57444	TIE, CABLE BLACK NYLON 5.62L	4
7	55939	WIRE CLIP, ADHESIVE	1
8	94762	SWITCH, IGNITION	1
10	690106	ASSY, SWITCH DOUBLE POLE DELTA	1
10-1	320082	SWITCH, DOUBLE	1
10-2	690074	BOOT, SWITCH	1
11	57769	BULB, INDICATOR	2
12	94136	SWITCH LIMIT	2
13	94613	SOLENOID	1
14	711619	SCREW, 1/4X.50	2
15	711632	NUT, 1/4-20 HEXNYL	2
16	95420	WIRE, GROUND	1
17	711619	SCREW, 1/4X.50	1
18	94159	SWITCH, SEAT	1
19	92739	BATTERY	1
20	711680	BOLT, 1/4-20X.63	2
21	711636	NUT, WING 1/4-20	2
22	335417	BOOT, BATTERY	1
25	711666	WASHER, FLAT	1
27	95330	TAPE SWITCH	1
28	95391	BUZZER, FOR BAG FULL	1
29	711579	WIRE, LEAD SOLENOID TO STARTER	1
39	94348	HARNESS ADAPTER	1
	302031	15 AMP FUSE	

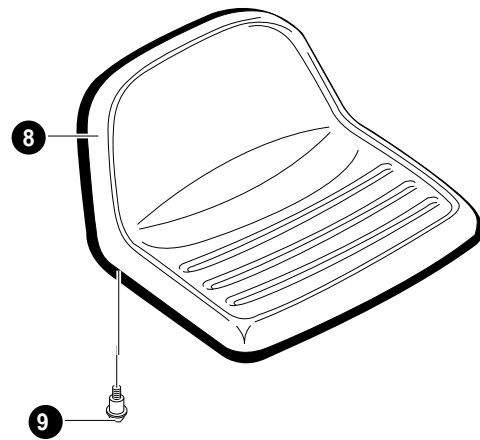
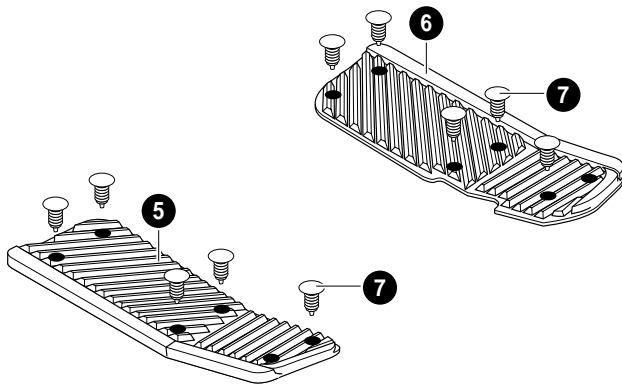
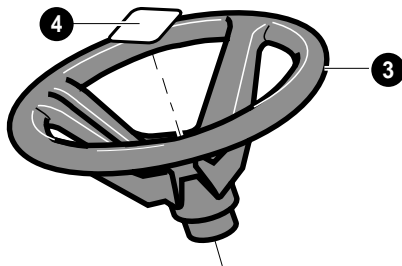
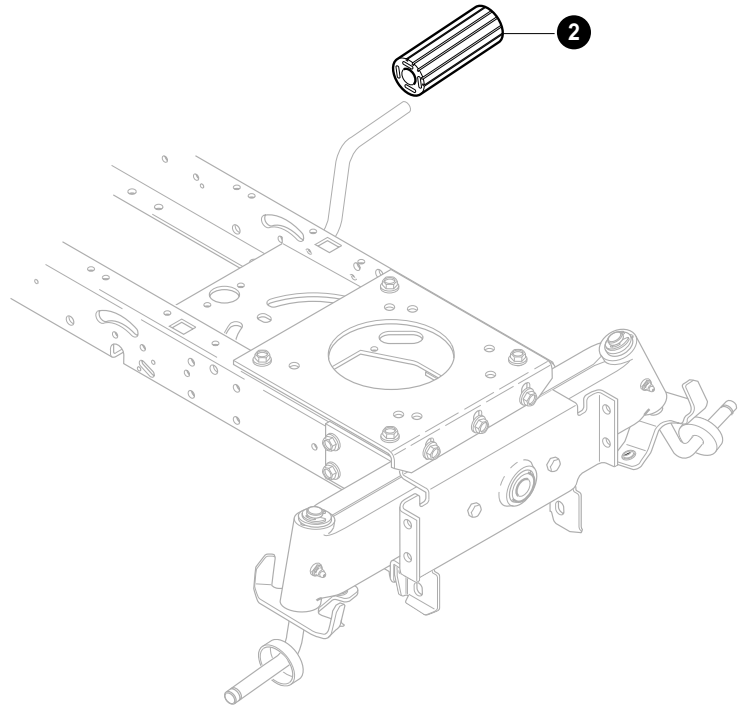

KEY NO.	PART NO.	DESCRIPTION	QTY
1	327349	IGNITION KEY	2
2	21544	COVER, PEDAL BRAKE/CLUTCH	1
3	95184	WHEEL, STEERING	1
4	711325	DECAL, PINCH POINTS	1
5	95438	FOOTREST PAD RH	1
6	95437	FOOTREST PAD LH	1
7	311087	RATCHET FASTENER	10
8	95444	SEAT	1
9	711654	BOLT, .375X.255 HSH 5/16-18	1

344866A