

NOTE: ALWAYS USE ORIGINAL EQUIPMENT PARTS.
Use of service/replacement parts other than original
equipment parts may void your warranty.

ALL UNNUMBERED
ITEMS ARE INTERCHANGEABLE
WITH OPPOSITE SIDE

344695A

KEY #	PART #	DESCRIPTION	QTY
1	95432-821	BRACKET, HOOD RH	1
2	95433-821	BRACKET, HOOD LH	1
3	711606	SCREW, 5/16-18X.75HHWATAP	4
4	94907	DASH	1
5	711762	SCREW, 1/4-14X.75 PHPANTAPABBL	2
6	95195-821	GUARD, HEAT SHIELD	1
8	302628	SCREW, 1/4-20X.75	2
9	71067	FLATWASHER .281X.63X.065	4
10	73826	NUT, 1/4-20 REGHXCTRLK	2
11	341569-898	ASSY. LOWER CONSOLE	1
11-1	95425	TOWER, LOWER DASH	1
11-2	95426	SUPPORT, STEERING/PTO	1
11-3	710264	SCREW 1/4-20X.50 WAHHTAP	4
11-4	95406	ROD, DASH BRACE	1
11-5	710264	SCREW, 1/4-20X.50 WAHHTAP	2
12	711606	SCREW, 5/16-18X.75 HHWATAP	4
15	94638-898	PANEL, ACCESS	1
16	711629	SCREW, 10-24X.500TRSEGI	2
17	94950	HOOD	1
18	302670	LENS, HEADLAMP	1
19	308492	FOIL, LENS HOOD REFLECTOR	2
21	301452	FOIL, HEAT REFLECTOR	2
22	711856	PIN, CLEVIS .375DIAX1.00LG	2
23	711682	HAIR PIN .38DIAX1.64LG	2
24	6711	WASHER, PLASTIC .315X.75X.064	4
25	95404	BUSHING, STEERING SHAFT	1
	712447	OPERATOR'S MANUAL (NOT SHOWN)	1

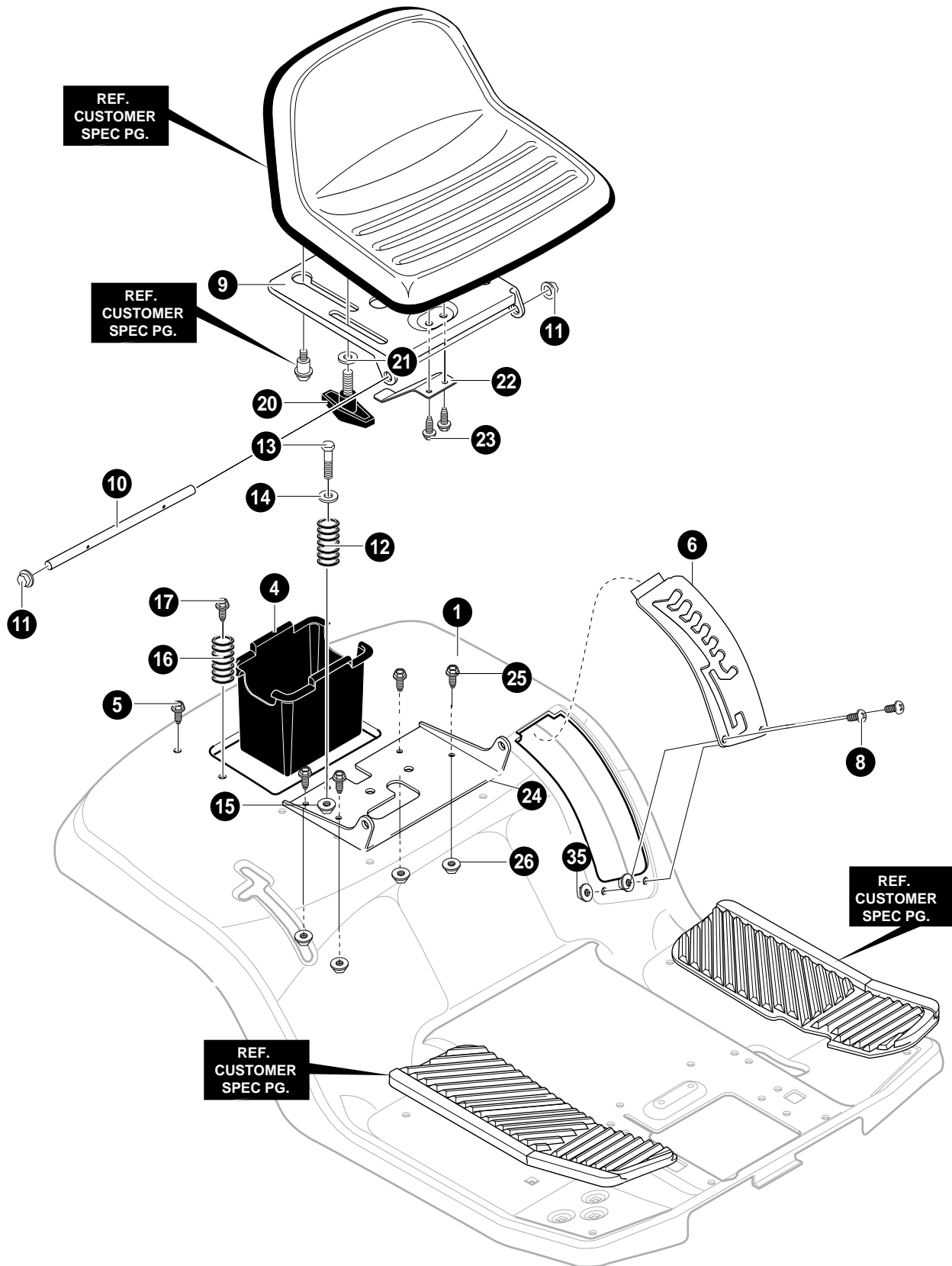

NOTE: ALWAYS USE ORIGINAL EQUIPMENT PARTS.
Use of service/replacement parts other than original
equipment parts may void your warranty.

ALL UNNUMBERED
ITEMS ARE INTERCHANGEABLE
WITH OPPOSITE SIDE

344864A

KEY #	PART #	DESCRIPTION	QTY
1	95249-898	SEAT DECK	1
4	94069	CONTAINER, BATTERY	1
5	711642	SCREW, 1/4-20X .63HHWATAPSERB	2
6	94829-821	PLATE, LIFT DETENT	1
7	-	NOT USED ON THIS UNIT	
8	711629	SCREW, 10-24X.500TRSEGI	2
9	94154-898	SEAT SUPPORT	1
10	95294	HINGE SEAT PIVOT	1
11	711627	NUT, PUSH CAP .375	2
12	710136	SPRING, COMPRESSION	1
13	711610	SHOULDER BOLT, 1/4-20)	1
14	95293	WASHER CUP	1
15	711643	NUT, 1/4-20 WDFLLK	1
16	710109	SPRING, COMPRESS 2.43LG 164X30	2
17	711606	SCREW, 5/16-18X.75HHWATAPSGIBP	2
20	711747	BOLT, WING 5/16-18	2
21	711644	WASHER, FLAT.344X .62X.06	2
22	94057	SPRING-LEAF	1
23	711592	SCREW 1/4-20X.50 WAHHTAP	2
24	94153-898	BRACKET, PIVOT SEAT	1
25	711606	SCREW, 5/16-18X.75 HHWATAP	4
26	711634	NUT, 5/16-18 WDFLLK	4
35	711842	NUT, #10-24 LOCK	2

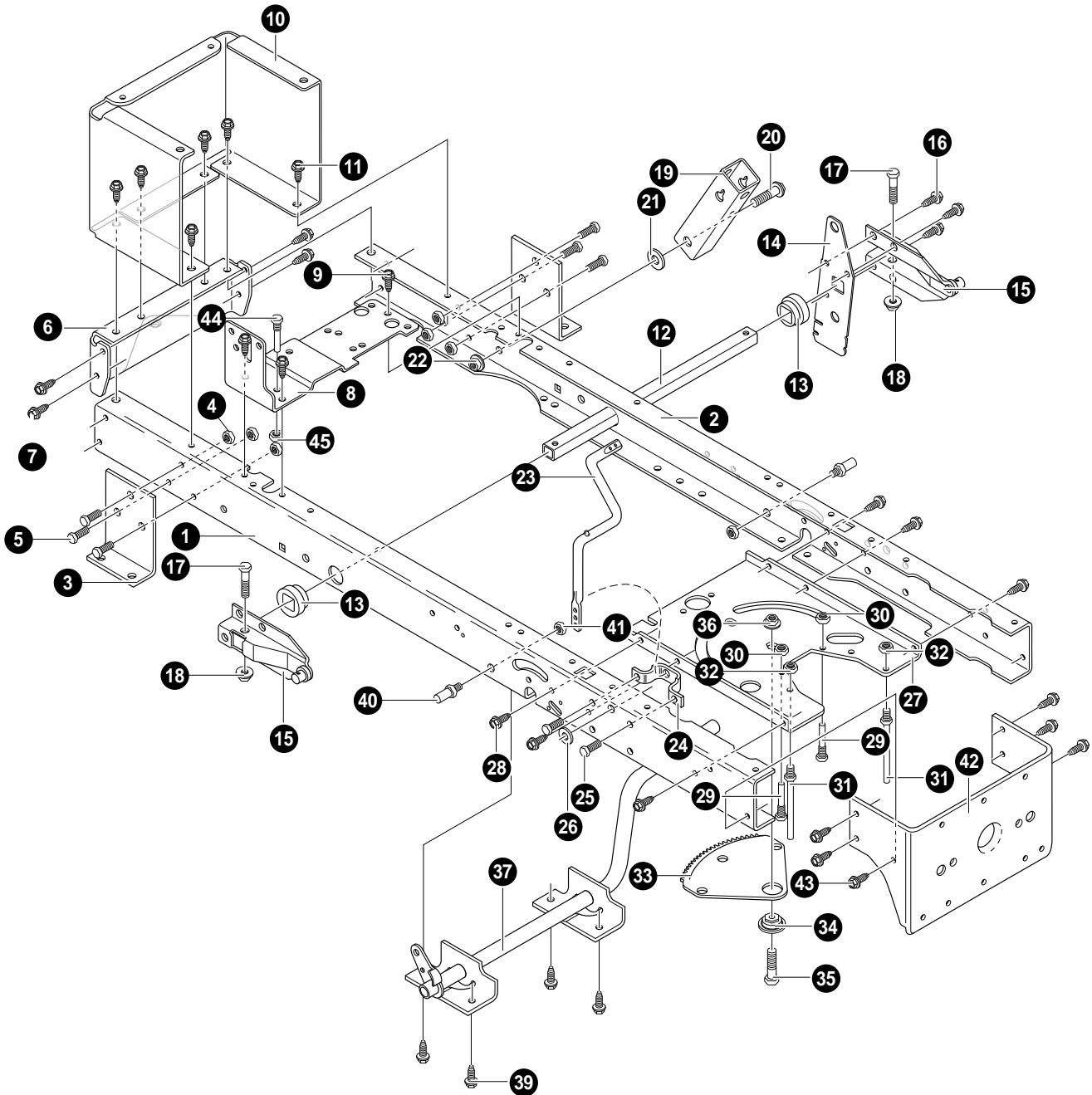

NOTE: ALWAYS USE ORIGINAL EQUIPMENT PARTS.
Use of service/replacement parts other than original
equipment parts may void your warranty.

ALL UNNUMBERED
ITEMS ARE INTERCHANGEABLE
WITH OPPOSITE SIDE

344294A

KEY #	PART #	DESCRIPTION	QTY
1	95110	FRAME, RAIL RH	1
2	95111	FRAME, RAIL LH	1
3	94008	BRACKET,TRANSAXLE	2
4	710205	NUT, 5/16-18 WDFLLK	6
5	710079	SCREW, 5/16-18X.75HHWATAPSGIBP	6
6	94002	HITCH PLATE	1
7	710079	SCREW, 5/16-18X.75HHWATAPSGIBP	4
8	690166	BRACKET, SHIFT RH	1
9	710079	SCREW, 5/16-18X.75HHWATAPSGIBP	3
10	94023	PANEL, REAR	1
11	710079	SCREW, 5/16-18X.75HHWATAPSGIBP	6
12	94063	TUBE, LIFTER	1
13	94065	BUSHING - LIFT TUBE	2
14	94030	PLATE-LIFT ARM	1
15	94180	ASSEMBLY, LIFT ARM LEVER	2
16	710106	SCREW,5/16-18X.50WHHTAPBK26X49	3
17	710310	SCREW, 5/16-24X1.25	2
18	710080	NUT, 5/16-24 NF-2 HEXFLLK	2
19	94015	BRACKET, PIVOT	1
20	710000	BOLT, .562X1.563 HSH 3/8-16	1
21	710130	WASHER, FLAT .406ID (17X191)	1
22	710140	NUT,3/8-16HWDFFLLK MACK 15X84	1
23	94019	CRANK, PTO (DRILLED)	1
24	94005	BRACKET, BELL CRANK	1
25	710079	SCREW, 5/16-18X.75HHWATAPSGIBP	2
26	120395	WASHER, FLAT .469X .92X.065	1
27	690167	PLATE,STEERING MOUNTING	1
28	710079	SCREW, 5/16-18X.75HHWATAPSGIBP	6
29	93349	SCREW GUIDE 5/16-18	2
30	710204	NUT,5/16-18 HEXWDFLLK WHIZ PL	2
31	94066	SCREW - GUIDE	2
32	710204	NUT,5/16-18 HEXWDFLLK WHIZ PL	2
33	94121	GEAR, SECTOR	1
34	94123	BEARING, SECTOR GEAR	1
35	710312	SCREW, 5/16-18X1.00 HHC	1
36	710105	NUT, 5/16-18 HWDFFLLK (15X113)	1
37	95075	ASSEMBLY, CL/BR ROD	1
39	710079	SCREW, 5/16-18X.75HHWATAPSGIBP	4
40	94067	PIN,THREADED SHOULDER	2
41	45171	NUT, 3/8-16 HWDFL WHIZ-LOCK	2
42	94013	BRACKET, HANGER REAR	1
43	710079	SCREW, 5/16-18X.75HHWATAPSGIBP	6
44	93349	ZINC SCREW GUIDE 5/16-18	1
45	710204	NUT, 5/16-18 HEXWDFLLK WHIZ	1

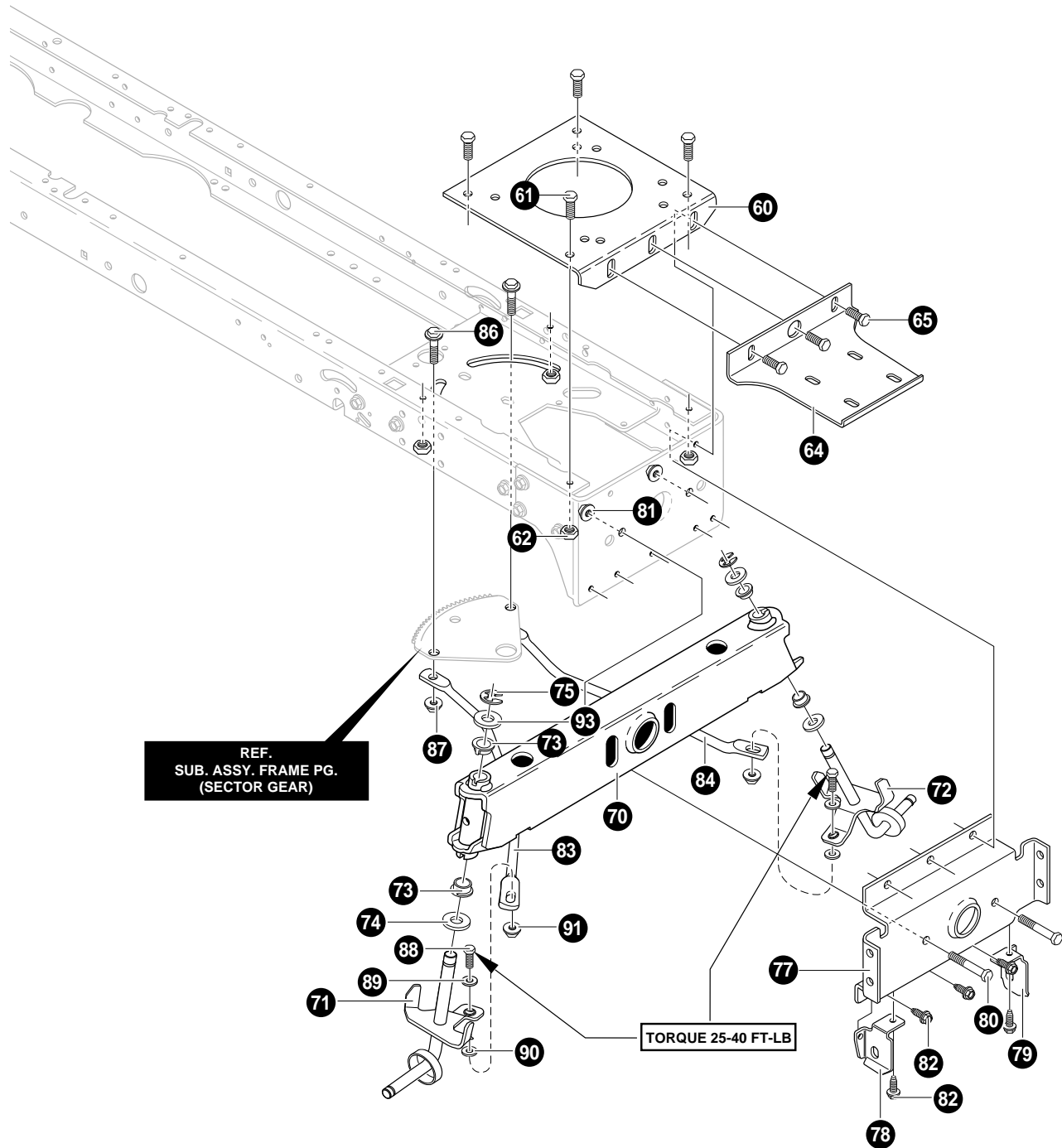

NOTE: ALWAYS USE ORIGINAL EQUIPMENT PARTS.
Use of service/replacement parts other than original
equipment parts may void your warranty.

ALL UNNUMBERED
ITEMS ARE INTERCHANGEABLE
WITH OPPOSITE SIDE

344294A

KEY #	PART #	DESCRIPTION	QTY
60	94006	PLATE, ENGINE	1
61	710079	SCREW, 5/16-18X.75 HHWATAP	4
62	710205	NUT, 5/16-18 WDFLLK	4
64	94901	BRACKET, MUFFLER	1
65	710079	SCREW, 5/16-18X.75 HHWATAP	3
70	690210	ASSY, AXLE SECTION	1
71	94178	SPINDLE, RH	1
72	94179	SPINDLE, LH	1
73	690150	BEARING-SPINDLE	4
74	710129	WASHER, .766IDX1.62ID	2
75	710103	E-RING .574IDX.050/.750SH	2
77	94007	HANGER, AXLE	1
78	94026	HANGER DECK RH	1
79	94027	HANGER DECK LH	1
80	710081	SCREW, 5/16-24X2.75	2
81	710080	NUT, 5/16-24 NF-2 HEXFLLK	2
82	710079	SCREW, 5/16-18X.75 HHWATAP	5
83	94020	DRAG LINK RH	1
84	94021	DRAG LINK, LH	1
86	710440	BOLT, HSSH	2
87	710140	NUT, 3/8-16HWDFFLLK MACK	2
88	710082	SCREW, 3/8-16X1.5	2
89	710083	WASHER, FLAT .391X1.00X.083	2
90	710142	WASHER, FLAT .406X.81X16GA	2
91	710140	NUT, 3/8-16 HWDFFLLK MACK	2
93	710088	WASHER, FLAT .765X1.81X.059	2

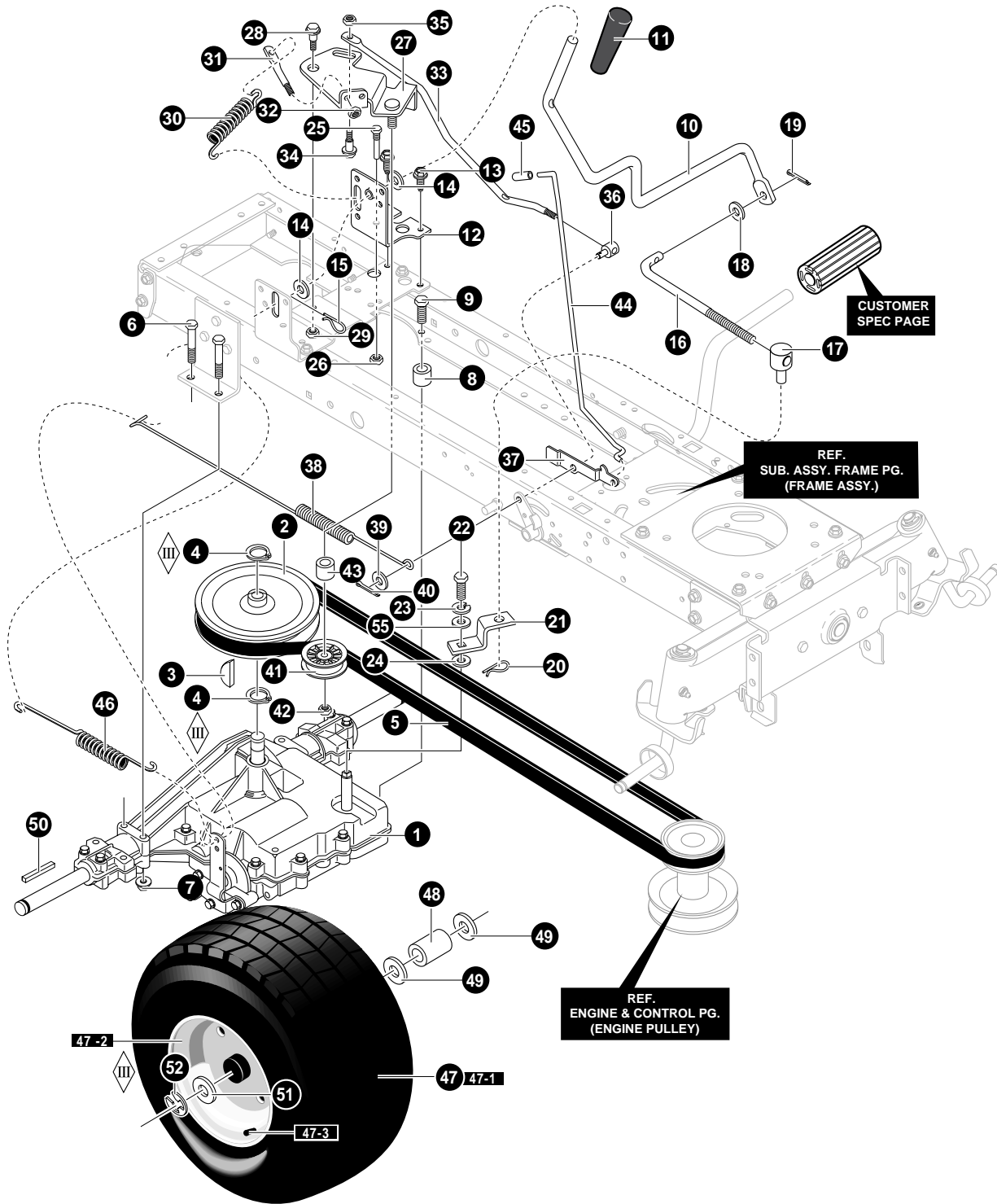

NOTE: ALWAYS USE ORIGINAL EQUIPMENT PARTS. Use of service/replacement parts other than original equipment parts may void your warranty.

ALL UNNUMBERED ITEMS ARE INTERCHANGEABLE WITH OPPOSITE SIDE

KEY #	PART #	DESCRIPTION	QTY
1	*	TRANSAXLE, PEERLESS MST205	1
2	95094	PULLEY, 8.81DIA.	1
3	20697	KEY, WDRF #9 .75DIA X.18X .310	1
4	710340	RING, RETEX .58X.04TRU (11X7)	2
5	710341	BELT, V (37X87)	1
6	711669	SCREW, 5/16-18X2.50	4
7	711634	NUT, 5/16-18 WDFLLK	4
8	94132	SPACER, TRANSAXLE	1
9	711605	SCREW, 5/16-18X2.00HHTFTH	1
10	690157	LEVER, SHIFTER	1
11	94929	GRIP, GREY	1
12	94034-821	BRACKET, SHIFT PIVOT	1
13	711606	SCREW, 5/16-18X.75HHWATAPSGIBP	2
14	711615	WASHER ,FLAT.518X.87X16	2
15	711676	PIN, HAIR	1
16	95289	LINK, SHIFT ZINC	1
17	711591	NUT,ADJ. 3/8-16TAP	1
18	711623	WASHER, FLAT.406X .81X16GA	1
19	71081	PIN,COTTER.094DIA.X.75	1
20	711682	PIN,HAIR.38 DIA X1.64LG	1
21	95286	ZINC YOKE-SHIFT	1
22	710345	SCREW, 1/4-28X .750HHCNYLK	1
23	710249	WASHER, (18X32)	1
24	710346	WASHER, .388X.393SQX1.00X.065	1
25	711745	SCREW GUIDE 5/16-18	2
26	710026	NUT,5/16-18 HEXWDFLLK WHIZ	2
27	690173-821	ASS'Y, IDLER ARM	1
28	711613	BOLT.50X.75 HSH 3/8-16	1
29	711622	NUT,3/8-16HWDFLLK MACK	1
30	710334	SPRING,EXTENSION 5.16LG	1
31	95288	STUD-SPRING MTG	1
32	710026	NUT,5/16-18 HEXWDFLLK WHIZ	1
33	95287	ROD,CLUTCH SWITCH ZINC	1
34	711646	BOLT, .50X.20HSH1/4-20X.50	1
35	711643	NUT, 1/4-20 WDFLLK	1
36	711596	NUT, ADJUSTING	1
37	95290	LATCH, PARK BRAKE ZINC	1
38	710333	SPRING, EXTENSION 23.10LG	1
39	711623	WASHER, FLAT.406X .81X16GA	1
40	71081	PIN,COTTER.094DIA.X.75LG	1
41	690409	PULLEY, IDLER	1
42	711920	NUT,3/8-16HWDFLLK MACK	1
43	690369	SPACER	1
44	690046	PARKING BRAKE CONTROL ROD	1
45	91079	GRIP	1
46	710353	SPRING, TENSION	1
47	338169	TIRE & RIM 18X8.50-8	2
47-1	338512	VALVE STEM	2
47-2	338524	RIM	2
47-3	338548	TIRE 18X8.5X8	2
48	95274	SPACER, .87X1.78	2
49	711648	WASHER, FLAT .760X1.25X.065	4
50	21553	KEY, SQUARE .187QX2.0LG	2
51	711758	WASHER, FLAT .765X1.81X.059	2
52	710103	E-RING .574IDX.050/.750SH (11X3)	2
55	710657	FLATWASHER .256X.75X.130	1

* CONTACT YOUR NEAREST PEERLESS TRANSAXLE DEALER FOR PARTS AND SERVICE.

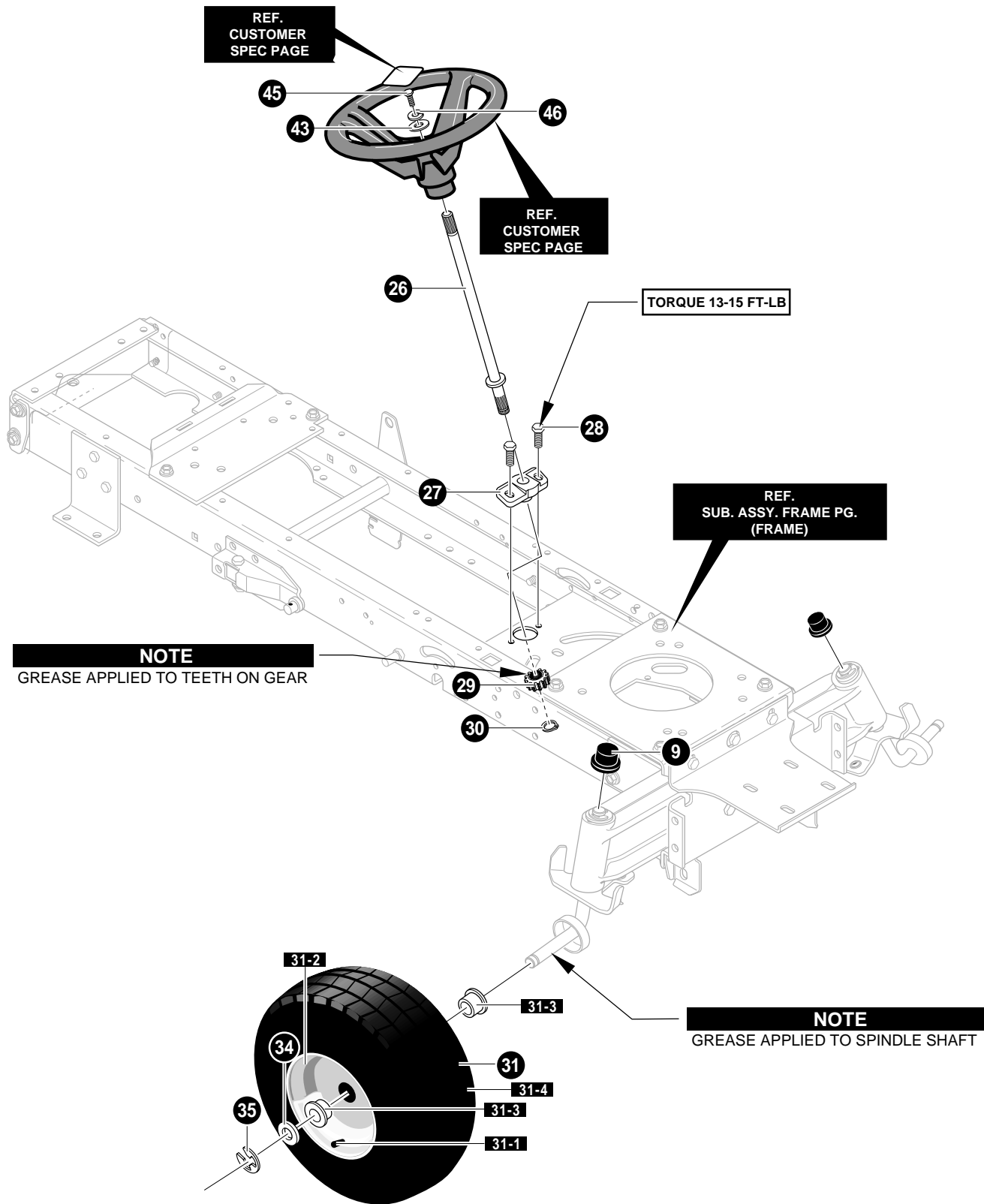

NOTE: ALWAYS USE ORIGINAL EQUIPMENT PARTS. Use of service/replacement parts other than original equipment parts may void your warranty .

ALL UNNUMBERED ITEMS ARE INTERCHANGEABLE WITH OPPOSITE SIDE

344787A

KEY #	PART #	DESCRIPTION	QTY
9	94618	DUST HUB CAP	2
26	94520	SHAFT, STEERING	1
27	94124	BEARING-LOWER	1
28	711606	SCREW, 5/16-18X.75HHWATAPSGIBP	2
29	94122	GEAR PINNION	1
30	710102	RING, RET E.54ID .59SH (11X25)	1
31	692641	TIRE&RIM, PU 15X6.0-6	2
31-1	338512	VALVE STEM	2
31-2	338517	RIM	2
31-3	338513	BEARING	2
31-4	338514	TIRE 15X6-6	2
34	711758	WASHER, FLAT .765X1.81X.059	2
35	710103	RING, RETEX .574IDX.050/.750SH 11X3	2
43	711720	FLATWASHER .391X1.25X.115	1
45	711719	SCREW, 1/4-20X.75	1
46	710249	WASHER (18X32)	1

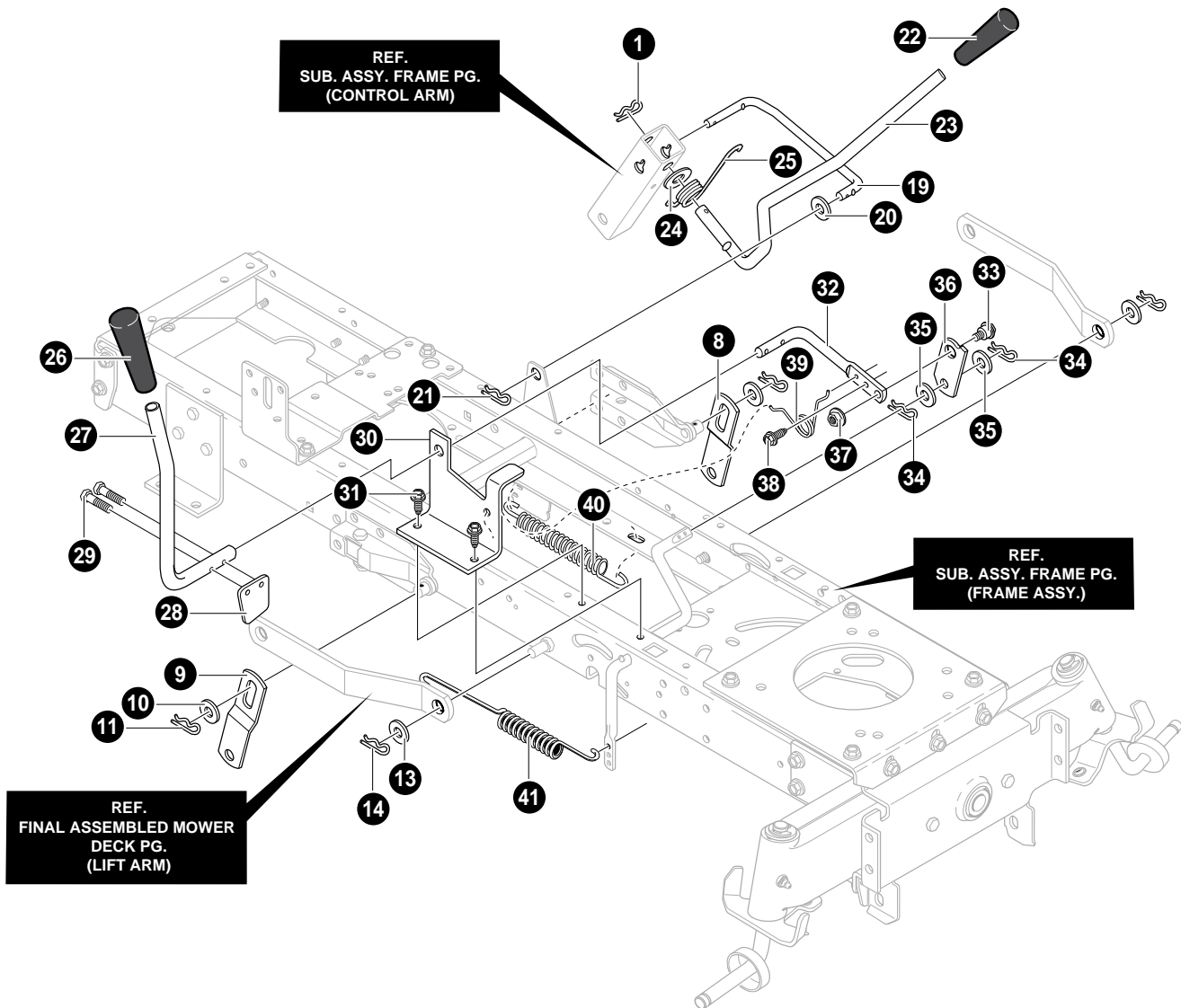

NOTE: ALWAYS USE ORIGINAL EQUIPMENT PARTS. Use of service/replacement parts other than original equipment parts may void your warranty.

ALL UNNUMBERED ITEMS ARE INTERCHANGEABLE WITH OPPOSITE SIDE

344308A

KEY #	PART #	DESCRIPTION	QTY
1	711676	HAIR PIN	1
8	94611-821	LINK, LIFT RH	1
9	94053-821	LINK-LIFT	1
10	711617	WASHER, FLAT	2
11	711676	HAIR PIN	2
13	711617	WASHER, FLAT	2
14	711676	HAIR PIN	2
19	95285	LINK LIFT HANDLE	1
20	711617	WASHER, FLAT	1
21	711676	HAIR PIN	1
22	94929	GRIP, GREY	1
23	690025	HANDLE, LIFT	1
24	711616	WASHER,FLAT .550X1.00X11	1
25	710111	TORSION SPRING .657LG (166X40)	1
26	94928	GRIP, GREY	1
27	690126	PTO HANDLE	1
28	95284	PADDLE, SWITCH	1
29	711621	SCREW, THD FORMING.246X1.050LG	2
30	94018-821	BRACKET, PTO	1
31	710708	BOLT, 5/16-18X.5 HXFLCA	2
32	95283	LEVER, PTO ZINC	1
33	711613	BOLT.50X.75 HSH 3/8-16	1
34	711659	PIN,HAIR .072DIAX1.13LG	2
35	711615	WASHER ,FLAT.518X.87X16	2
36	95282	LINK PTO ZINC	1
37	711622	NUT,3/8-16HWDFLLK MACK	1
38	711606	SCREW, 5/16-18X.75HHWATAPSGIBP	1
39	710141	TORSION SPRING .33LG (166X39)	1
40	710311	SPRING, TENSION 1.01OD 8.18LG	1
41	710229	EXTEN. SPRING 11.16LG 165X118	1

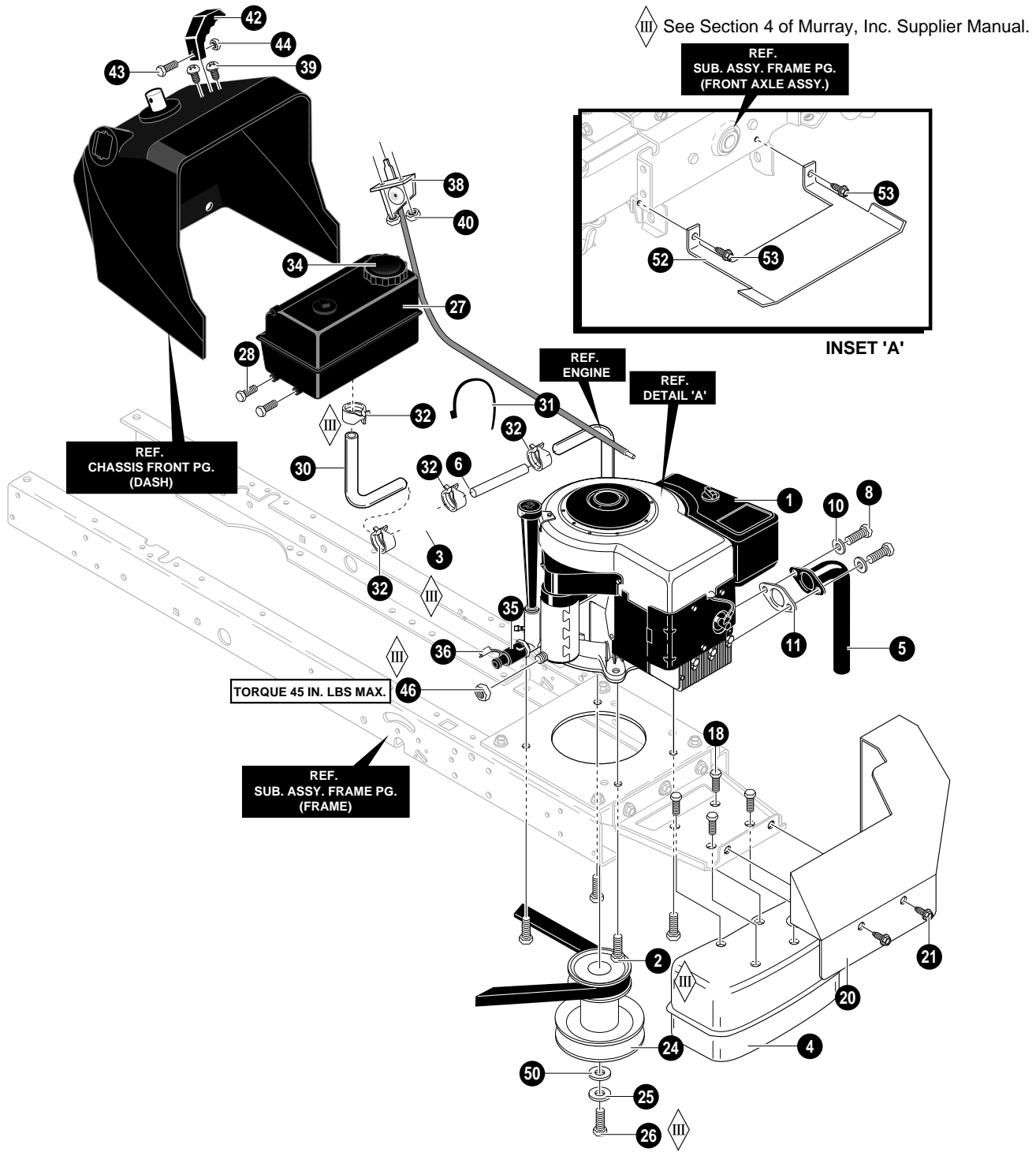

NOTE: ALWAYS USE ORIGINAL EQUIPMENT PARTS. Use of service/replacement parts other than original equipment parts may void your warranty.

ALL UNNUMBERED ITEMS ARE INTERCHANGEABLE WITH OPPOSITE SIDE

344713A

KEY #	PART #	DESCRIPTION	QTY
1	ENGINE	12.5HP BS (SEE ENGINE MANUAL)	1
2	710199	SCREW, 3/8-16X1.25 WAHHSPTAPP	4
3	690494	FUEL SHUT-OFF	1
4	94902	MUFFLER SUPER LOW TONE	1
5	94900	EXHAUST PIPE	1
6	309306	GAS TUBING	3.250 IN.
8	313676	SCREW, 5/16-18X.75	2
10	313679	WASHER, HVSP TLK .328X.60X.09	2
11	91309	GASKET, MUFFLER	1
18	711642	SCREW, 1/4-20X.75 WAHHTAP	4
20	94904-821	HEAT SHIELD	1
21	711606	SCREW, 5/16-18X.75 HHWATAP	2
22	710247	FLATWASHER .480X1.00X.25	1
24	95257	PULLEY STACK ASSY	1
25	120383	WASHER, REGSPTLK .459X.78X.12	1
26	710248	SCREW, 7/16-20X.	1
27	309853	TANK, FUEL 1.5 WO/SENSOR	1
28	711681	SCREW, 15TPIX PANHTAP	4
30	48252	TUBING, GAS LINE .25X.50	8.00 IN.
31	57444	CABLE TIE	1
32	47345	CLAMP, HOSE SCREW TYPE	2
34	12501	FUEL CAP	1
35	325547	OIL DRAIN VALVE ASSEMBLY	1
36	327422	CAP,OIL DRAIN VALVE ASM.YELLOW	1
38	95370	THROTTLE CONTROL	1
39	711755	SCREW, 10-24X.63 PHFLTMA	2
40	711754	NUT, #10-24 HXHDNYLK	2
42	94931	KNOB, THROTTLE CONTROL	1
43	711750	SCREW, #8-32X.38 PHPNMA	2
44	711748	NUT, #8-32 REGHX	1
46	711601	NUT 1/4-20 REGHXJAM	1
50	710247	WASHER, FLAT .480X1.00X.25	1
51	71061	WASHER, EXLK .32X.60X.04	1
52	95192-821	SHIELD, ANIT-DEHYDRATION	1
53	711606	SCREW, 5/16-18X.75 HHWATAP	2

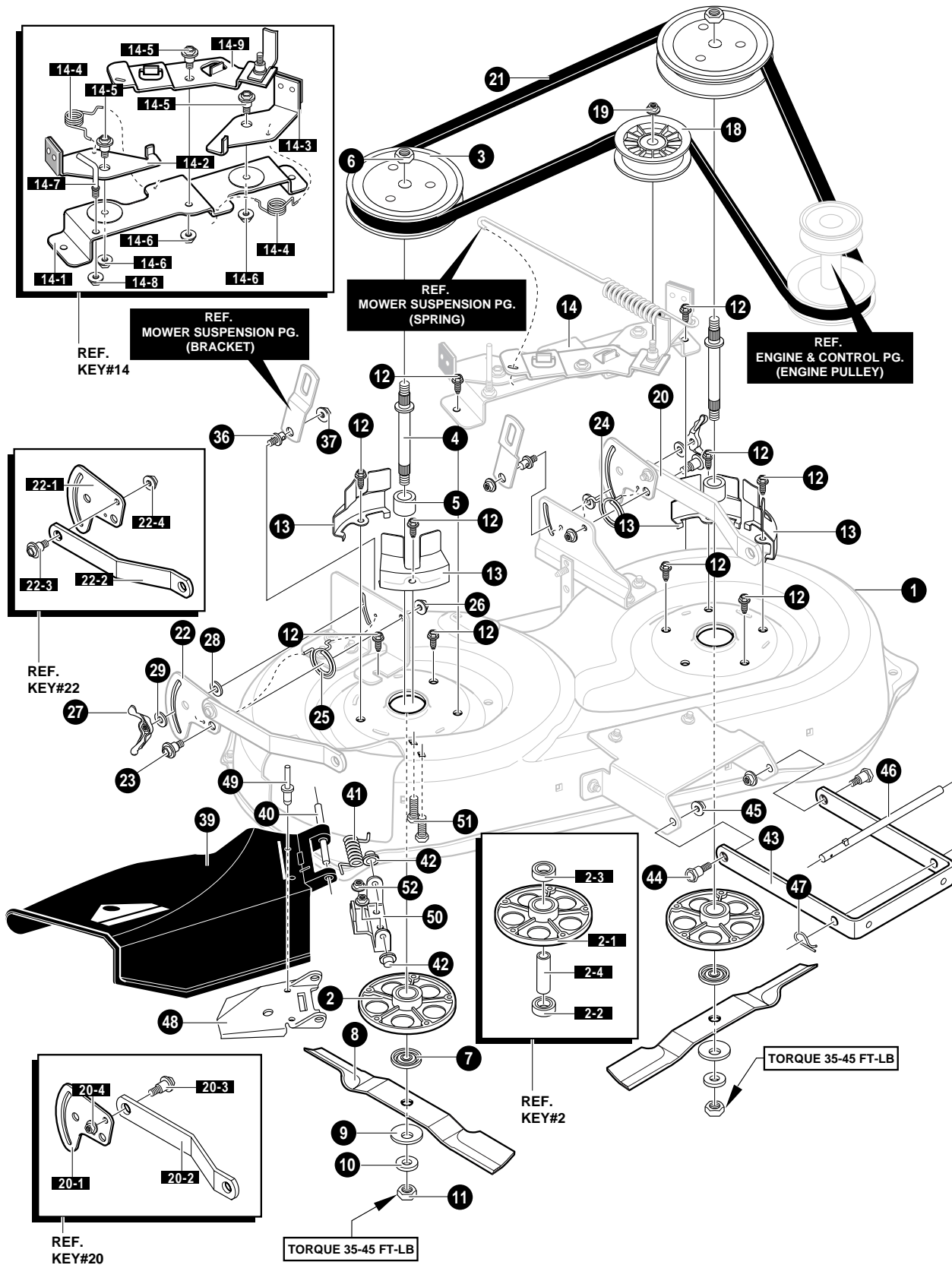

NOTE: ALWAYS USE ORIGINAL EQUIPMENT PARTS. Use of service/replacement parts other than original equipment parts may void your warranty .

ALL UNNUMBERED ITEMS ARE INTERCHANGEABLE WITH OPPOSITE SIDE

344305A

KEY#	PART #	DESCRIPTION	QTY
1	94061-821	38" MOWER DECK ASSY	1
2	690222	JACKSHAFT HOUSING ASM.	2
3	690174	ZINC PULLEY, QUILL 38" DECK	2
4	94129	JACKSHAFT 7.12LG	2
5	94130	SPACER, JACKSHAFT	2
6	711626	NUT, 9/16-18 UNF-2B (15X121)	2
7	92466	ADAPTER, DECK/BLADE 38"	2
8	94913	BLADE, 38" EXPORT	2
9	710118	WASHER, FLAT.625X1.75 17X166	2
10	710117	WASHER,FLAT .625X1.00X.188	2
11	710104	NUT, 9/16 REGHEX	2
12	710199	SCREW, 3/8-16X1.25 WAHHSPTAPP	10
13	94051-821	COVER, SEGMENT BELT GUIDE	4
14	94691-821	ASM., BRAKE WITH SUPPORT 38"	1
14-1	94059	BRACKET, BRAKE MTG	1
14-2	94047	ASSY, BRAKE RH	1
14-3	94049	ASSY, BRAKE LH	1
14-4	710227	TORSION SPRING .55LG (166X41)	1
14-5	710098	BOLT, HSSH 3/8-16 (9X39)	1
14-6	710140	NUT, 3/8-16 MACK 15X84	1
14-7	94781	SCREW-GUIDE	1
14-8	710204	NUT, 5/16-18 HEXWDFLLK WHIZ	1
14-9	94177	ASSY, IDLER ARM	1
18	91801	PULLEY, IDLER BFF 4.75DIA.	1
19	711622	NUT,3/8-16HWDFLLK MACK	1
20	690159-821	ASM.PLATE,REAR SUS.BRKT.LH	1
20-1	94128	PLATE - SUSPENSION	1
20-2	94055	SUSPENSION BRKT REAR	1
20-3	710095	BOLT, SHOULDER 3/8-16 (9X52)	1
20-4	710140	NUT,3/8-16HWDFLLK MACK (15X84)	1
21	710193	BELT, BARBACK, CL 84.24(37X86)	1
22	690158-821	ASM. PLATE,REAR SUS.BRKT.RH	1
22-1	94128	PLATE - SUSPENSION	1
22-2	94055	SUSPENSION BRKT REAR	1
22-3	710095	BOLT, SHOULDER 3/8-16 (9X52)	1
22-4	710140	NUT,3/8-16HWDFLLK MACK	1
23	711611	BOLT, SHOULDER .375	2
24	710113	SPRING,TORSION .68LG LH (166X43)	1
25	710112	SPRING,TORSION .68LG RH (166X42)	1
26	711622	NUT,3/8-16HWDFLLK MACK	2
27	711600	WINGNUT 5/16-18	2
28	94137	PAD, FRICTION	2
29	711628	WASHER	2
36	711595	PIN, HANGER	2
37	711622	NUT, 3/8-16 HWDFLLK MACK	2
39	94687	DEFLECTOR CHUTE	1
40	95303	ASM. BRACKET IDLER	1
41	710194	SPRING, TORS .44 X2.06X .	1
42	711627	NUT, PUSH CAP .375	2
43	94058-821	BRACKET, FRT SUSPENSION	1
44	711611	BOLT, SHOULDER .375	2
45	711622	NUT,3/8-16HWDFLLK MACK	2
46	95295	ZINC ROD, HANGER	1
47	711676	PIN, HAIR	2
48	94686-821	SUPPORT, DEFLECTOR CHUTE	1
49	711624	RIVET - SEMI .244X.250 (7X125)	2
50	94956-821	BRACKET, CHUTE ATTACH	1
51	711661	BOLT, 5/16-18X.63 CARR.	2
52	711634	NUT 5/16-18 WDFLLK	2

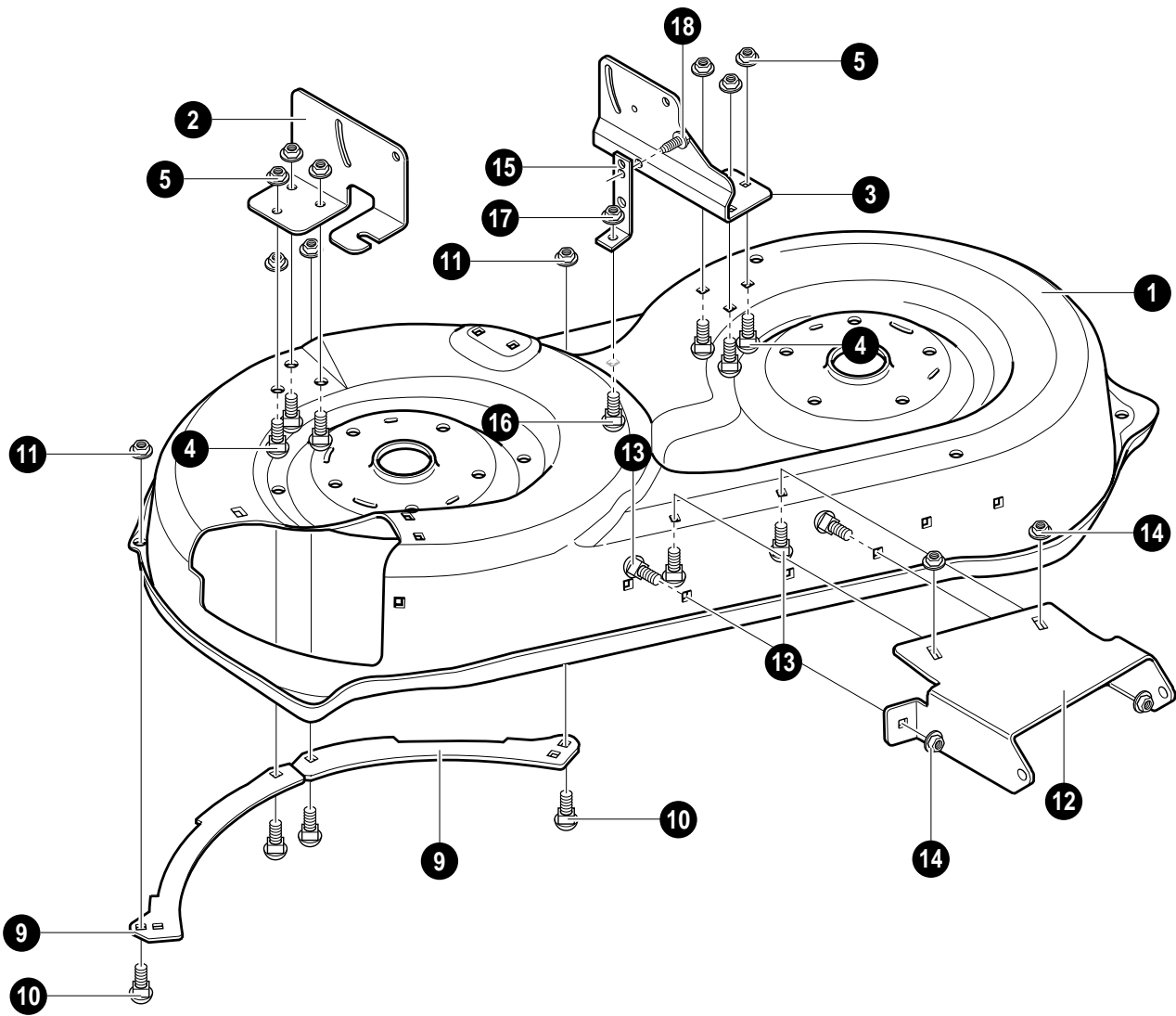

NOTE: ALWAYS USE ORIGINAL EQUIPMENT PARTS.
Use of service/replacement parts other than original
equipment parts may void your warranty .

ALL UNNUMBERED
ITEMS ARE INTERCHANGEABLE
WITH OPPOSITE SIDE

94061B

KEY#	PART #	DESCRIPTION	QTY
1	94060	38" MOWER DECK	1
2	94052	BRACKET,DECK LIFT RH	1
3	94054	BRACKET,DECK LIFT LH	1
4	57072	BOLT, 5/16-18X .63 CARRLN	6
5	710204	NUT,5/16-18 HEXWDFLLK WHIZ PL	6
9	91770	TOEGUARD, FLANGE 38" DECK	2
10	57072	BOLT, 5/16-18X .63 CARRLN	4
11	710205	NUT, 5/16-18 WDFLLK (15X88)	4
12	94062	BRACKET - 38" FRT DECK	1
13	57072	BOLT, 5/16-18X .63 CARRLN	4
14	710204	NUT,5/16-18 HEXWDFLLK WHIZ PL	4
15	94681	BRACKET, SUPPORT	1
16	57072	BOLT, 5/16-18X .63 CARRLN	1
17	710204	NUT,5/16-18 HEXWDFLLK WHIZ PL	1
18	710079	SCREW, 5/16-18X.75HHWATAPSGIBP	1

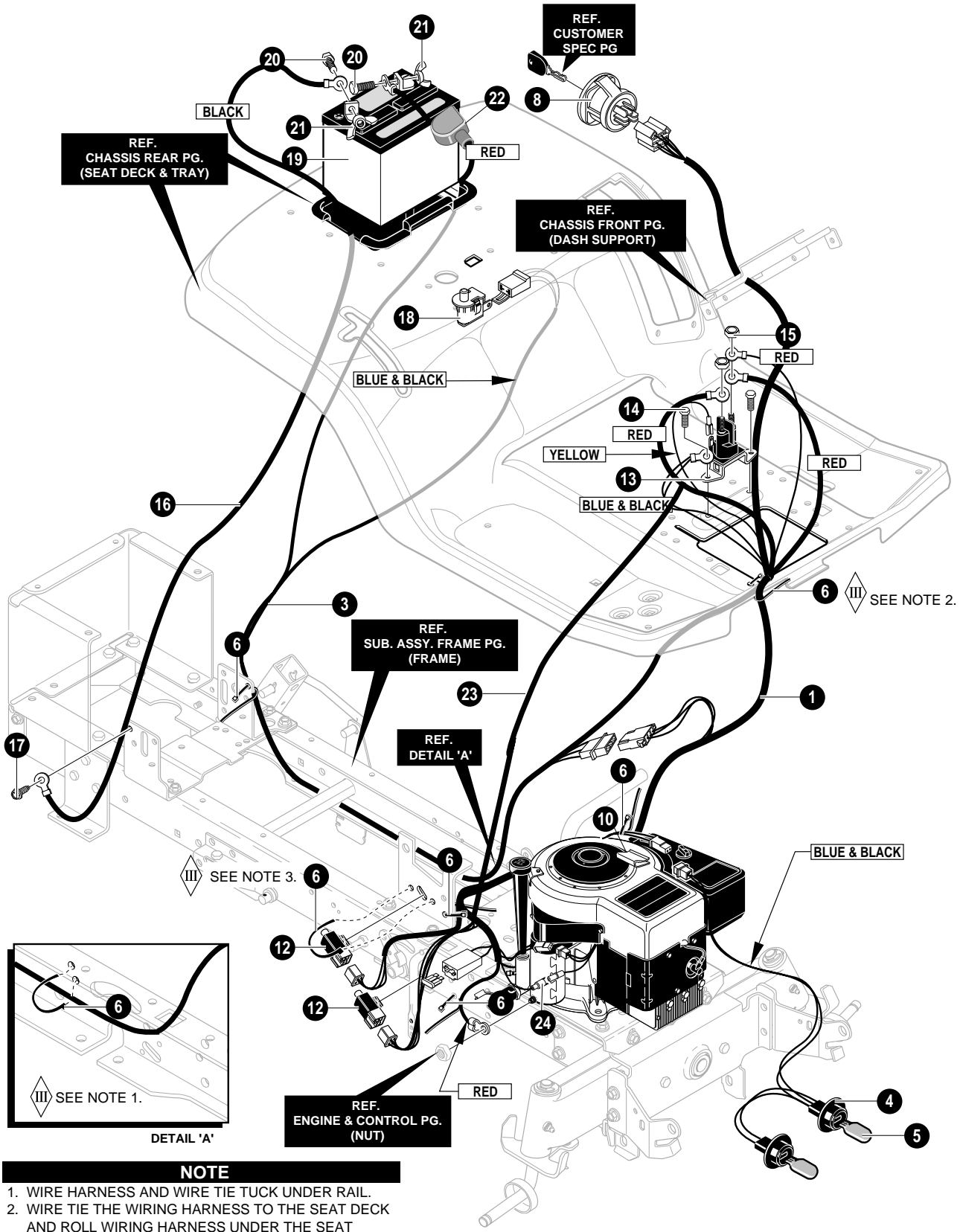

NOTE

1. WIRE HARNESS AND WIRE TIE TUCK UNDER RAIL.
2. WIRE TIE THE WIRING HARNESS TO THE SEAT DECK AND ROLL WIRING HARNESS UNDER THE SEAT DECK TO ELIMINATE A PINCH POINT.
3. WIRE TIE PTO SWITCH TO PTO BRACKET.

KEY #	PART #	DESCRIPTION	QTY
1	95201	HARNESS 12.5 B&S	1
3	340530	WIRE HARNESS, REAR	1
4	94103	WIRE HARNESS FOR HEADLIGHTS	1
5	52572	BULB, HEADLAMP	2
6	57444	TIE, CABLE BLACK NYLON 5.62L	7
8	94762	SWITCH, IGNITION 7 TERM	1
10	55939	WIRE CLIP, ADHESIVE	1
12	94136	SWITCH LIMIT DELTA 6400-84	2
13	94613	SOLENOID	1
14	711619	SCREW,HHWATAP 1/4X.50	2
15	711632	NUT, 1/4-20 HEXNYL	2
16	710228	WIRE, GROUND (24X32) NLT	1
17	711760	SCREW, 1/4X.75HWAT TYPE AB	1
18	94159	SWITCH, SEAT	1
19	302257	BATTERY, 12 PLATE, 7 PLATE	1
20	711680	BOLT,1/4-20X.63CAR	2
21	711636	NUT, WING 1/4-20 NC	2
22	335417	BOOT, BATTERY	1
23	711579	WIRE, LEAD SOLENOID TO STARTER	1
24	94348	HARNESS ADAPTER	1
	302031	FUSE 15 AMP	

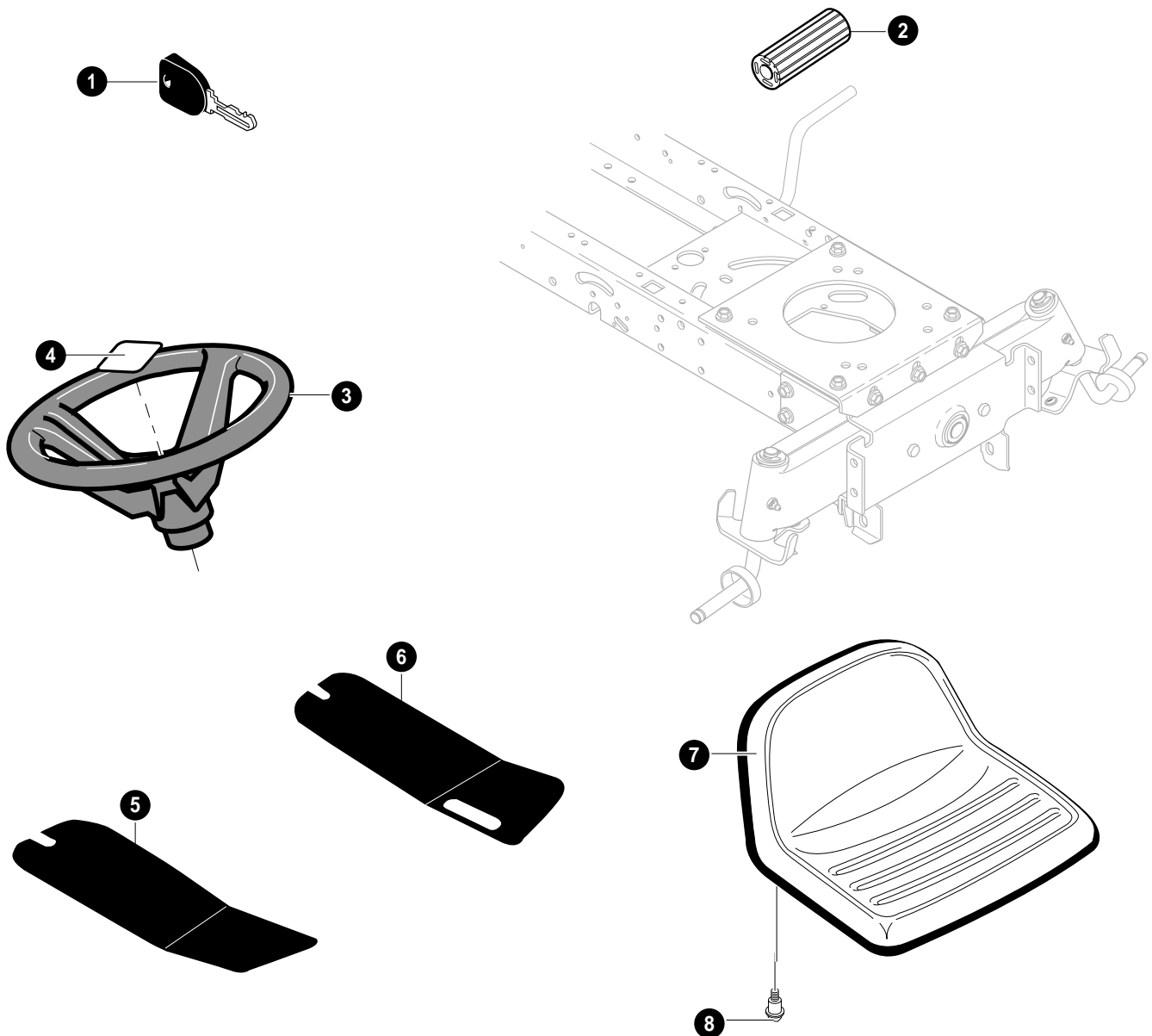

KEY #	PART #	DESCRIPTION	QTY
1	327350	KEY, IGNITION SWITCH	2
2	21544	COVER, PEDAL BRAKE/CLUTCH	1
3	95335	STEERING WHEEL 3-SPOKE	1
4	95337	INSERT, STEER WHEEL	1
5	94998	MAT, RH RUN BOARD	1
6	94999	MAT, LH RUN BOARD	1
7	95334	SEAT	1
8	711740	BOLT, SHOULDER 5/16-18	1

344873A