



Green Passion

Illustrated Parts List

XM 130-XM 140HD-XM 160HD
Model Year 2011

- Use GLOBAL GARDEN PRODUCT Genuine Spare Parts specified in the parts list for repair and/or replacement.
- The contents described in the parts list may change due to improvement.
- The drawings of the spare parts are only indicative and might not represent the part in question exactly.
- The indications "right" - "left" - "front" - "rear" refer to the position of the operator when using the machine.
- When placing orders of parts for repair and/or replacement, make sure that the illustrated parts list is the one applying to the machine's year of manufacture, as shown on the identification plate attached to the machine.

COPYRIGHT by GLOBAL GARDEN PRODUCTS

All rights reserved. No part of this material may be reproduced or transmitted, in any form or by any means, electronic or mechanical, including photocopying, recording or by any information storage and retrieval system, without permission in writing from GLOBAL GARDEN PRODUCTS.

21

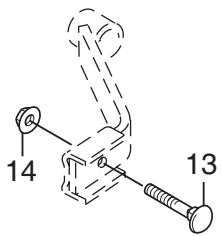
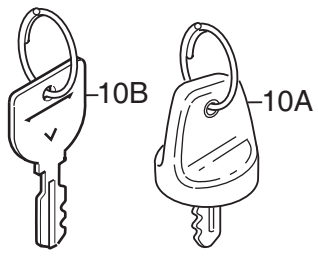
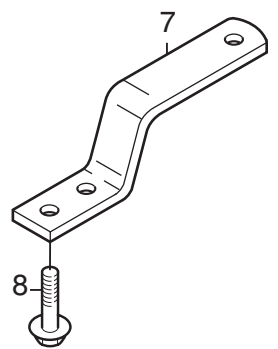
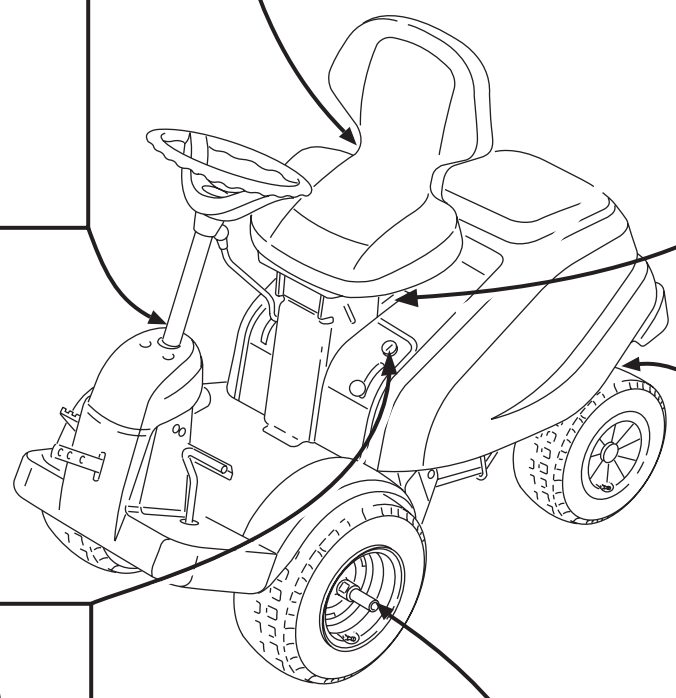
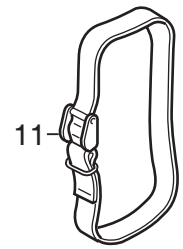
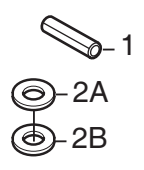
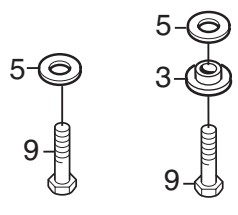
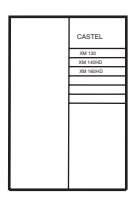

12

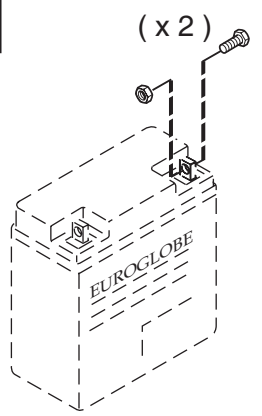

Ausgabe Issue 2011-31		Bild Nr Picture No C067C			XM 130 XM 140 HD- XM 160 HD MONTAGETEILEN	XM 130 XM 140 HD- XM 160 HD ASSEMBLY PARTS	Seite Page 28		
Pos. Fig.	Anzahl/Quantity				Artikel Nr. Part No	Bezeichnung	Description	Satz Kit	Anmerkung Notes
	2781 -31 -91	2782 -30 -90	2783 -30 -90						
1	1	1	1		9595-0262-00	Spannstift	Locating pin		
2A	1	1	1		9699-0103-02	Scheibe.....	Flat washer.....		0.5 mm
2B	1	1	1		9699-0114-02	Scheibe.....	Flat washer.....		1.0 mm
3	2	2	2		1134-4185-01	Flanschscheibe	Flange washer		
5	4	4	4		9699-0056-02	Scheibe.....	Flat washer.....		
7	1	1	1		1134-4627-01	Anhängerstrebe	Tow bar		
8	2	2	2		9959-0820-16	Schraube	Screw.....		
9	4	4	4		9997-0820-16	Schraube	Screw.....		
10A	1	1	1		1134-4734-01	Zündschlüssel	Ignition key		
10B	1	1	1		1134-6125-01	Zündschlüssel	Ignition key		
11	1	1	1		1134-5245-01	Batterieriemen	Battery strap		
12	1	1	1		1134-6113-01	Batterieschrauben.....	Battery screws		
13	2	2	2		9898-1035-16	Schraube	Screw.....		
14	2	2	2		9739-1031-22	Mutter	Nut		
X X X	21	1	1		8211-0079-10	Bedienungsanleitung	Owner's manual		France
	21	1	1		8211-0081-11	Bedienungsanleitung	Owner's manual		
	21	1	1		8211-0701-10	Sicherheitsvorschrift	Safety regulations		

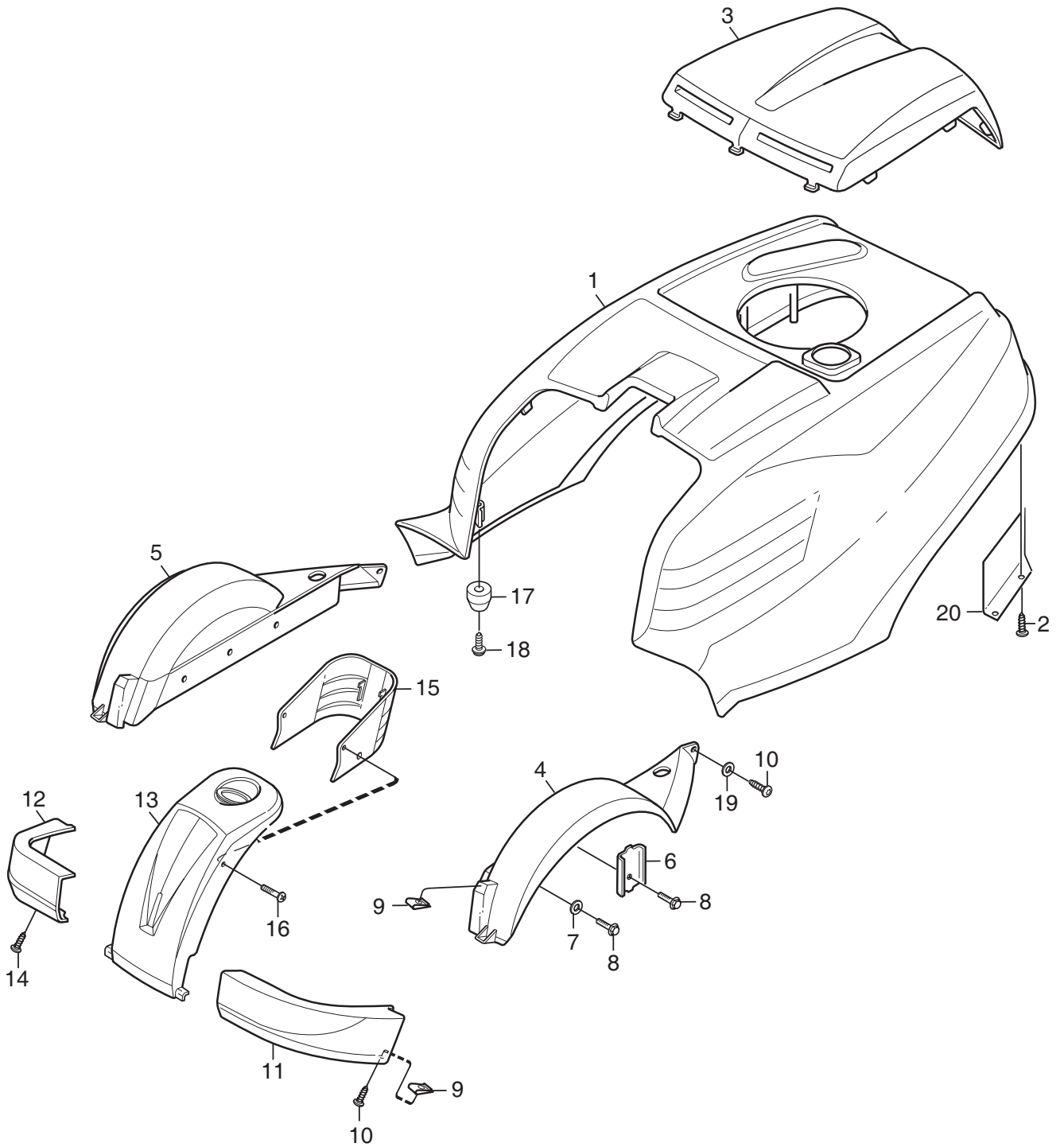

Ausgabe Issue 2011-31		Bild Nr Picture No C068B		XM 130 XM 140 HD- XM 160 HD KAROSSERIE		XM 130 XM 140 HD- XM 160 HD BODY WORK		Seite Page 30	
Pos. Fig.	Anzahl/Quantity			Artikel Nr. Part No	Bezeichnung	Description	Satz Kit	Anmerkung Notes	
	2781 -31 -91	2782 -30 -90	2783 -30 -90						
1	1	1	1	1134-5392-01	Motorhaube- rot.....	Engine hood- red.....			
2	7	7	7	9838-9530-12	Schraube	Screw			
3	1	1	1	1134-5393-01	Motordeckel- grau	Engine cover- grey			
4	1	1	1	1134-5307-05	Kotflügel- L	Mud guard- LH			
5	1	1	1	1134-5307-06	Kotflügel- R.....	Mud guard- RH			
6	2	2	2	1137-0088-01	Stützblech.....	Support plate			
7	4	4	4	9699-0056-02	Scheibe.....	Flat washer.....			
8	6	6	6	9945-0816-16	Schraube	Screw			
9	4	4	4	1134-4176-01	Klemme	Clips			
10	4	4	4	9893-0616-16	Schraube	Screw.....			
11	1	1	1	1134-5367-01	Stoßfänger- vorder, L.....	Bumper- front, LH			
12	1	1	1	1134-5367-02	Stoßfänger- vorder, R	Bumper- front, RH.....			
13	1	1	1	1134-5362-01	Vorderteil- untere.....	Front- lower			
14	6	6	6	9893-0616-16	Schraube	Screw			
15	1	1	1	1134-5361-01	Vorderdeckel	Front cover.....			
16	2	2	2	9840-8013-16	Schraube	Screw.....			
17	2	2	2	1134-4790-02	Haubenführung.....	Hood guide			
18	2	2	2	9838-9530-12	Schraube	Screw			
19	2	2	2	9699-0060-02	Scheibe.....	Flat washer.....			
20			1	1134-6199-01	Deflektor	Deflector			

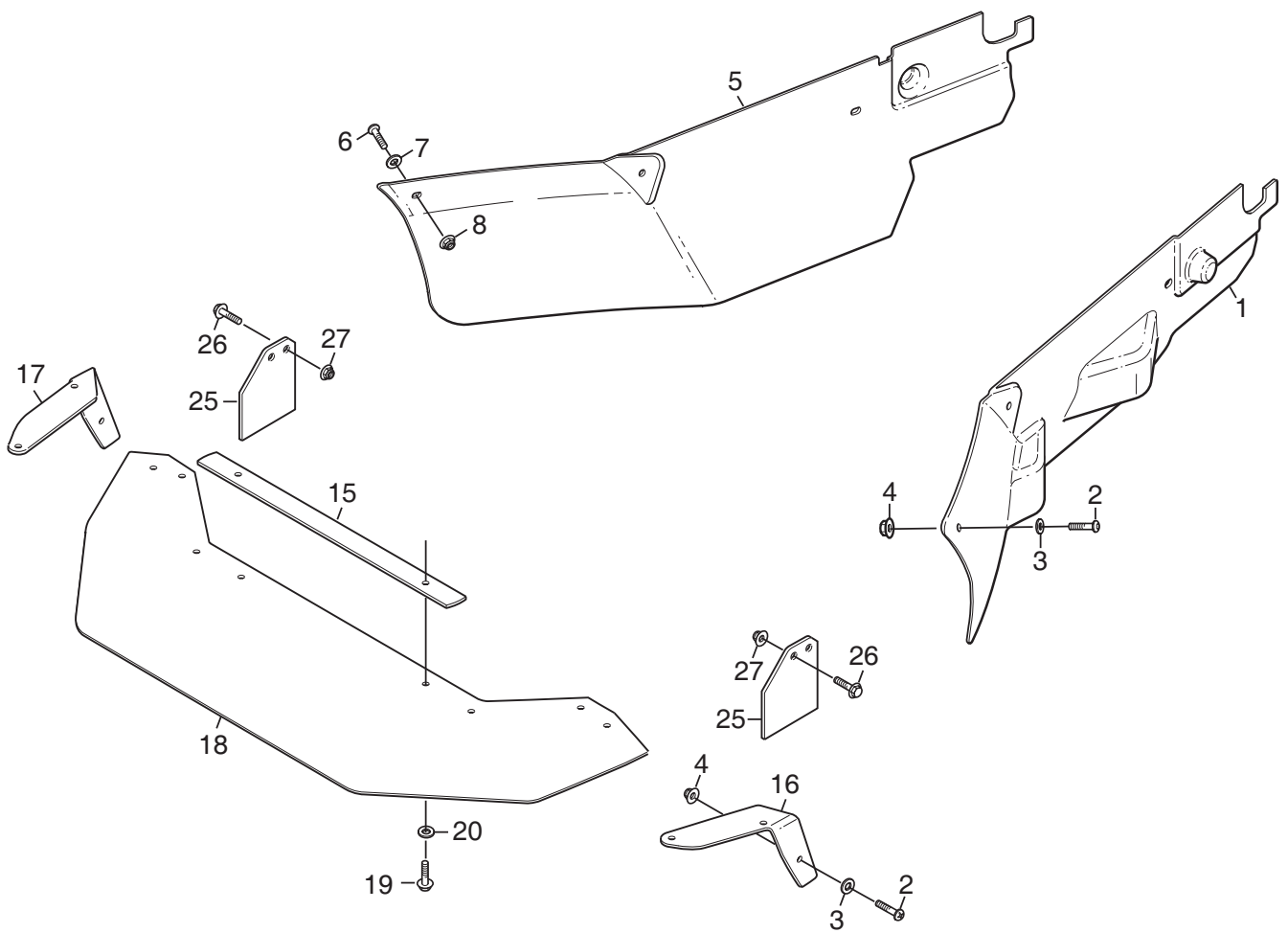

Ausgabe Issue 2011-31		Bild Nr Picture No 2819		XM 130 XM 140 HD- XM 160 HD KAROSSERIE (Frankreich)		XM 130 XM 140 HD- XM 160 HD BODY WORK (France)		Seite Page 32	
Pos. Fig.	Anzahl/Quantity			Artikel Nr. Part No	Bezeichnung	Description	Satz Kit	Anmerkung Notes	
	2781 -31	2782 2783 -30							
X	1	1	1	1137-0226-02	Seitenschutz- L	Side guard- LH			
	2	2	2	9893-0616-16	Schraube	Screw			
	3	2	2	9699-0060-02	Scheibe	Flat washer			
	4	2	2	9739-0631-22	Mutter	Nut			
X	5	1	1	1137-0248-02	Seitenschutz- R	Side guard- RH			
	6	2	2	9893-0616-16	Schraube	Screw			
	7	2	2	9699-0060-02	Scheibe	Flat washer			
	8	2	2	9739-0631-22	Mutter	Nut			
X	15	1	1	1137-0229-01	Halterung	Bracket			
X	16	1	1	1137-0230-01	Halterung- L	Bracket- LH			
X	17	1	1	1137-0230-02	Halterung- R	Bracket- RH			
X	18	1	1	1137-0228-02	Gummischutz	Rubber sheet			
	19	2	2	9959-0620-16	Schraube	Screw			
	20	2	2	9699-0060-02	Scheibe	Flat washer			
X	25	2	2	1137-0231-01	Schutz	Guard			
	26	2	2	9959-0820-16	Schraube	Screw			
	27	2	2	9739-0831-22	Mutter	Nut			

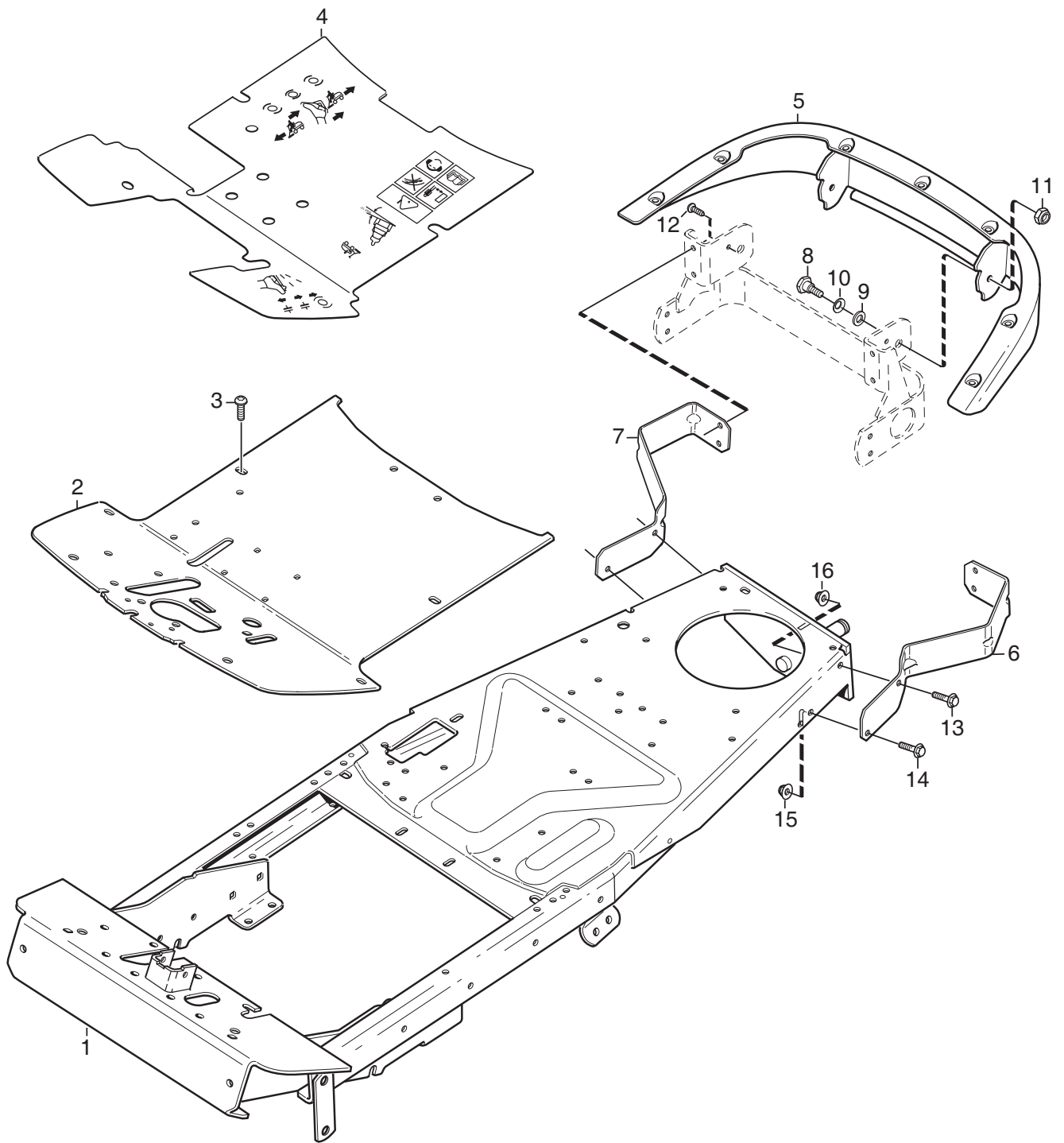

Ausgabe Issue 2011-31		Bild Nr Picture No 1642B		XM 130 XM 140 HD- XM 160 HD RAHMEN		XM 130 XM 140 HD- XM 160 HD FRAME		Seite Page 34	
Pos. Fig.	Anzahl/Quantity			Artikel Nr. Part No	Bezeichnung	Description	Satz Kit	Anmerkung Notes	
	2781 -31 -91	2782 -30 -90	2783 -30 -90						
1	1	1	1	1134-6635-01	Rahmen	Frame			
2	1	1	1	1134-5293-02	Bodenblech	Floor plate			
3	2	2	2	9893-0616-16	Schraube	Screw			
4	1			1134-5338-02	Bodenblechmatte	Floor mat			
4		1	1	1134-5339-02	Bodenblechmatte	Floor mat			
5	1	1	1	1134-5453-02	Stoßfänger- hintere	Bumper- rear			
6	1	1	1	1134-6630-01	Halterung- L	Attachment- LH			
7	1	1	1	1134-6630-02	Halterung- R	Attachment- RH			
8	2	2	2	1134-0240-00	Ansatzbolzen	Shoulder screw			
9	2	2	2	1134-4242-01	Distanzscheibe	Spacer washer			
10	2	2	2	9694-0001-00	Scheibe	Washer			
11	2	2	2	9747-0831-02	Mutter	Lock nut			
12	2	2	2	9943-0516-16	Schraube	Screw			
13	2	2	2	9959-0820-16	Schraube	Screw			
14	2	2	2	9959-0825-16	Schraube	Screw			
15	1	1	1	9739-0831-22	Mutter	Nut			
16	3	3	3	9739-0831-22	Mutter	Nut			

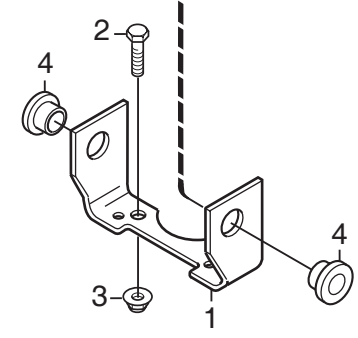
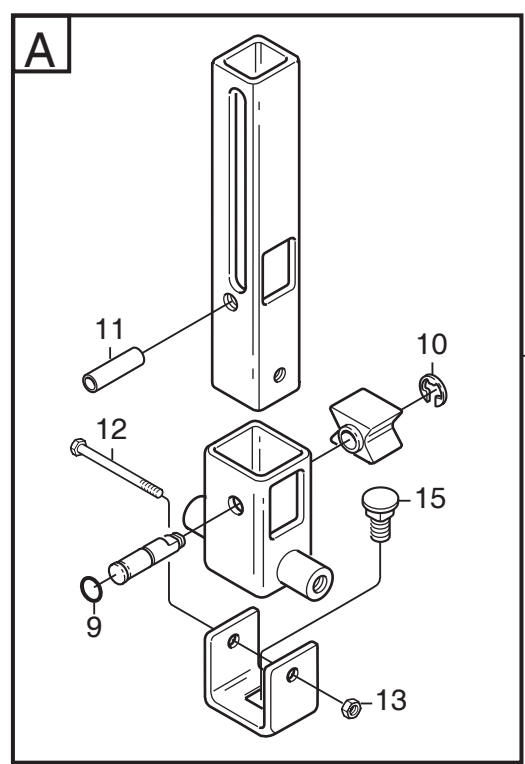
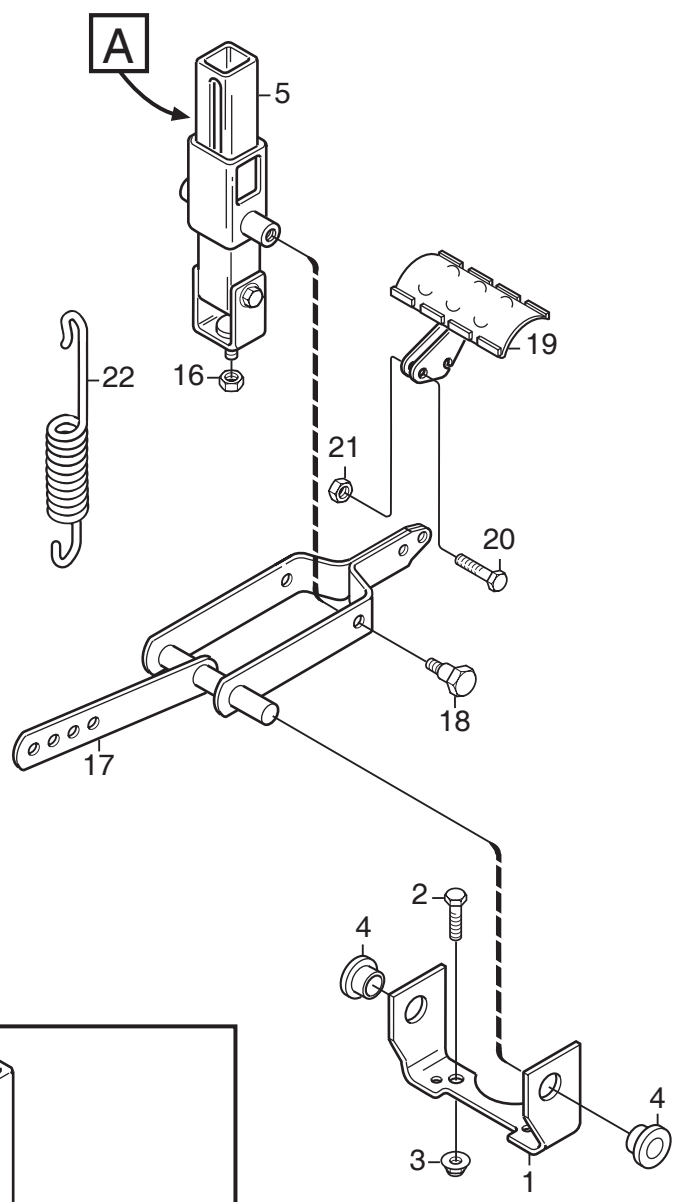

Ausgabe Issue 2011-31		Bild Nr Picture No C070		XM 130 XM 140 HD- XM 160 HD PEDALHEBER		XM 130 XM 140 HD- XM 160 HD PEDAL LIFT		Seite Page 36	
Pos. Fig.	Anzahl/Quantity				Artikel Nr. Part No	Bezeichnung	Description	Satz Kit	Anmerkung Notes
	2781 -31 -91	2782 -30 -90	2783 -30 -90						
1	1	1	1		1134-4117-01 Halterung.....	Bracket.....		Pos 9 - 15 incl.	
2	2	2	2		9959-1025-16 Schraube.....	Screw.....			
3	2	2	2		9739-1031-22 Mutter.....	Nut.....			
4	2	2	2		1134-2684-01 Lager.....	Bearing.....			
5	1	1	1		1134-4945-01 Hebesperre Kpl.....	Lift catch assy.....			
9	1	1	1		9404-0027-01 • O-ring.....	• O-ring.....			
10	1	1	1		9650-0039-04 • Schließring.....	• Lock ring.....			
11	1	1	1		9595-0276-01 • Spannstift.....	• Locating pin.....			
12	1	1	1		9997-0640-12 • Schraube.....	• Screw.....			
13	1	1	1		9747-0631-02 • Mutter.....	• Lock nut.....			
15	1	1	1		9897-0820-16 • Schraube.....	• Screw.....			
16	1	1	1		9747-0831-02 Mutter.....	Lock nut.....			
17	1	1	1		1134-4860-01 Hebegabel.....	Lift fork.....			
18	2	2	2		1134-0240-00 Ansatzbolzen.....	Shoulder screw.....			
19	1	1	1		1134-4938-01 Hebepedal.....	Lift pedal.....			
20	2	2	2		9997-0625-16 Schraube.....	Screw.....			
21	2	2	2		9739-0631-22 Mutter.....	Nut.....			
22	1	1	1		4231-0013-00 Feder.....	Spring.....			

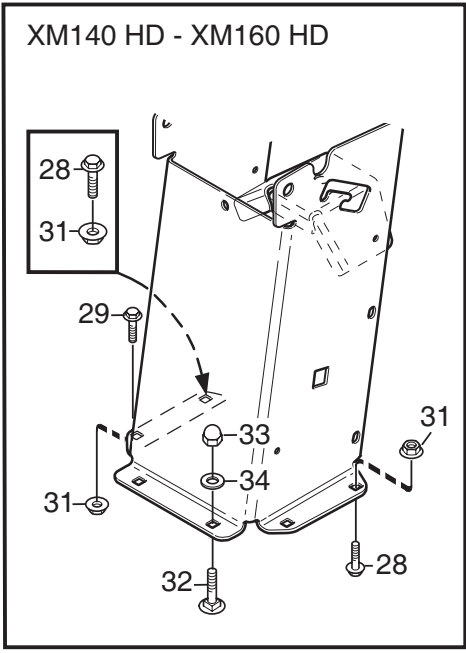
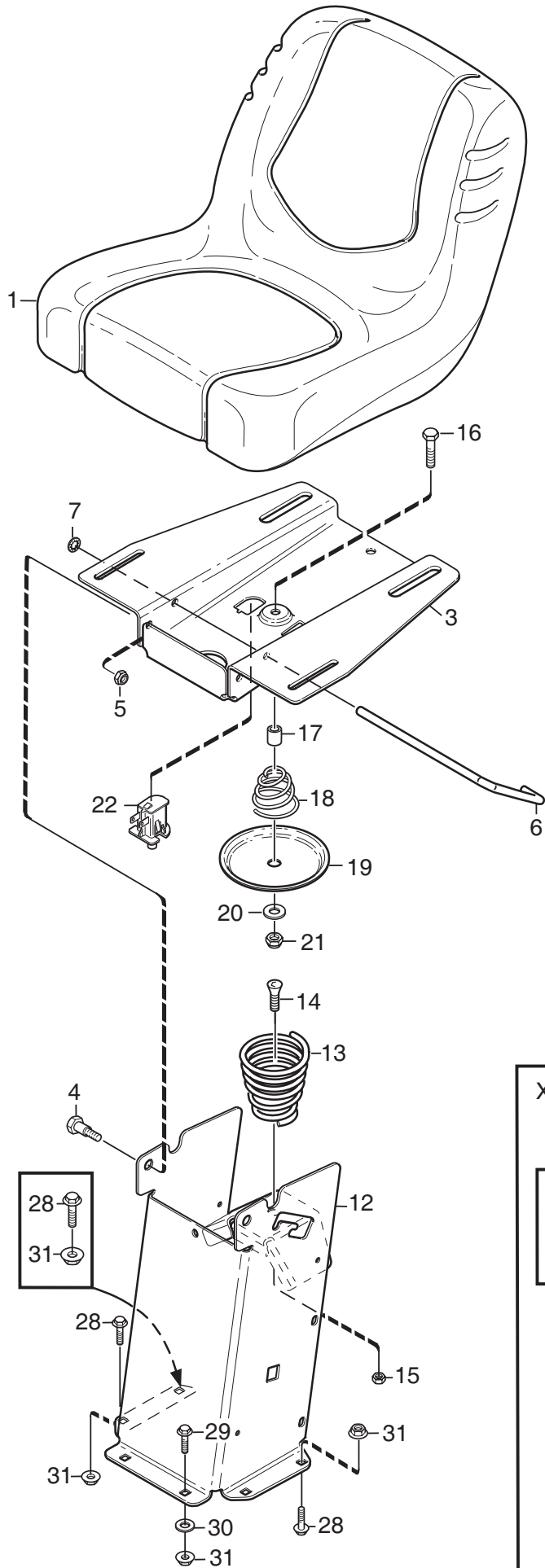

Ausgabe Issue 2011-31		Bild Nr Picture No C071B		XM 130 XM 140 HD- XM 160 HD SITZ		XM 130 XM 140 HD- XM 160 HD SEAT		Seite Page 38	
Pos. Fig.	Anzahl/Quantity			Artikel Nr. Part No	Bezeichnung	Description	Satz Kit	Anmerkung Notes	
	2781 -31 -91	2782 -30 -90	2783 -30 -90						
1	1	1	1	1134-5534-01	Sitz	Seat			
3	1	1	1	1134-5301-01	Sitzplatte	Seat plate			
4	2	2	2	1134-0240-00	Ansatzbolzen	Shoulder screw			
5	2	2	2	9747-0831-02	Mutter	Lock nut			
6	1	1	1	1134-5454-01	Sperre	Catch			
7	1	1	1	9675-0012-02	Verriegelungsscheibe	Locking washer			
12	1	1	1	1134-5296-05	Sitzkonsole- schw.	Seat bracket- black			
13	1	1	1	1134-4256-01	Sitzfeder	Seat spring			
14	1	1	1	9924-1235-19	Schraube	Screw			
15	1	1	1	9747-1231-02	Mutter	Lock nut			
16	1	1	1	9997-0840-12	Schraube	Screw			
17	1	1	1	1134-1565-06	Distanz	Spacer			
18	1	1	1	1134-5302-01	Feder	Spring			
19	1	1	1	1134-5299-01	Druckplatte	Push plate			
20	1	1	1	9699-0090-02	Scheibe	Flat washer			
21	1	1	1	9747-0831-02	Mutter	Lock nut			
22	1	1	1	1134-3156-02	Schalter (grau)	Switch (grey)			
28	4	4	3	9959-0820-16	Schraube	Screw		L = 20 mm	
29	2	1	1	9959-0825-16	Schraube	Screw		L = 25 mm	
30	2			9699-0056-02	Scheibe	Flat washer			
31	6	4	4	9739-0831-22	Mutter	Nut			
32		2	2	9897-0820-16	Schraube	Screw			
33		2	2	9757-0821-02	Mutter	Cap nut			
34		2	2	9699-0090-02	Scheibe	Flat washer			

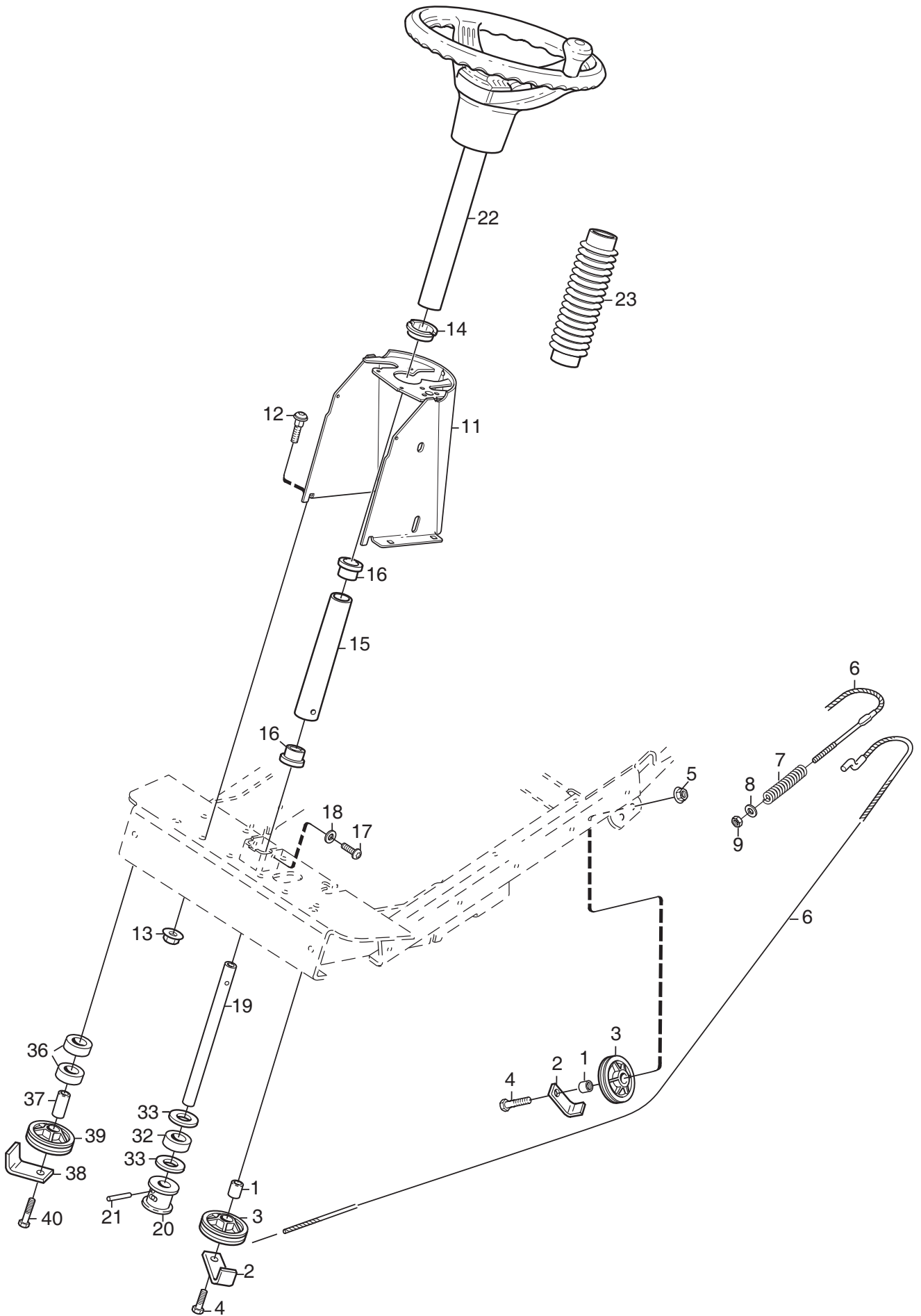

C072A

Ausgabe Issue 2011-31		Bild Nr Picture No C072A		XM 130 XM 140 HD- XM 160 HD LENKUNG		XM 130 XM 140 HD- XM 160 HD STEERING		Seite Page 40	
Pos. Fig.	Anzahl/Quantity			Artikel Nr. Part No	Bezeichnung	Description	Satz Kit	Anmerkung Notes	
	2781 -31 -91	2782 -30 -90	2783 -30 -90						
1	3	3	3	1134-0041-01	Hülse	Bushing			
2	3	3	3	1134-0046-00	Drahthalter	Wire clamp			
3	3	3	3	1134-0072-02	Seilrolle	Steering pulley			
4	3	3	3	9997-1040-16	Schraube	Screw			
5	2	2	2	9739-1031-22	Mutter	Nut			
6	1	1	1	1137-0093-01	Lenkdrahtseil	Steering cable			
7	1	1	1	1134-1310-01	Druckfeder	Compression spring			
8	1	1	1	9699-0056-02	Scheibe	Flat washer			
9	1	1	1	9747-0831-02	Mutter	Lock nut			
11	1	1	1	1134-5349-05	Lenkkonsole- grau	Steering console- grey			
12	4	4	4	9897-0820-16	Schraube	Screw			
13	4	4	4	9739-0831-22	Mutter	Nut			
14	1	1	1	1134-4483-01	Buchse	Bushing			
15	1	1	1	1134-1305-05	Lenkrohr- untere	Steering column- lower			
16	2	2	2	1134-1901-01	Lager	Bearing			
17	2	2	2	9893-0616-16	Schraube	Screw			
18	2	2	2	9699-0060-02	Scheibe	Flat washer			
19	1	1	1	1134-5495-01	Lenkstange	Steering rod			
20	1	1	1	1134-1933-01	Lenkrolle	Steering pulley			
21	1	1	1	9595-0262-00	Spannstift	Locating pin			
22	1	1	1	1134-5533-01	Lenkrad	Steering wheel			
23	1	1	1	1134-5545-01	Lenkstangenschutz	Steering tube muff			
32	1	1	1	1134-3047-01	Distanz	Spacer			
33	2	2	2	9699-0104-02	Scheibe	Washer			
36	2	2	2	1134-3047-01	Distanz	Spacer			
37	1	1	1	1134-0041-05	Hülse	Bushing			
38	1	1	1	1134-0046-00	Drahthalter	Wire clamp			
39	1	1	1	1134-0072-02	Seilrolle	Steering pulley			
40	1	1	1	9997-1060-12	Schraube	Screw			

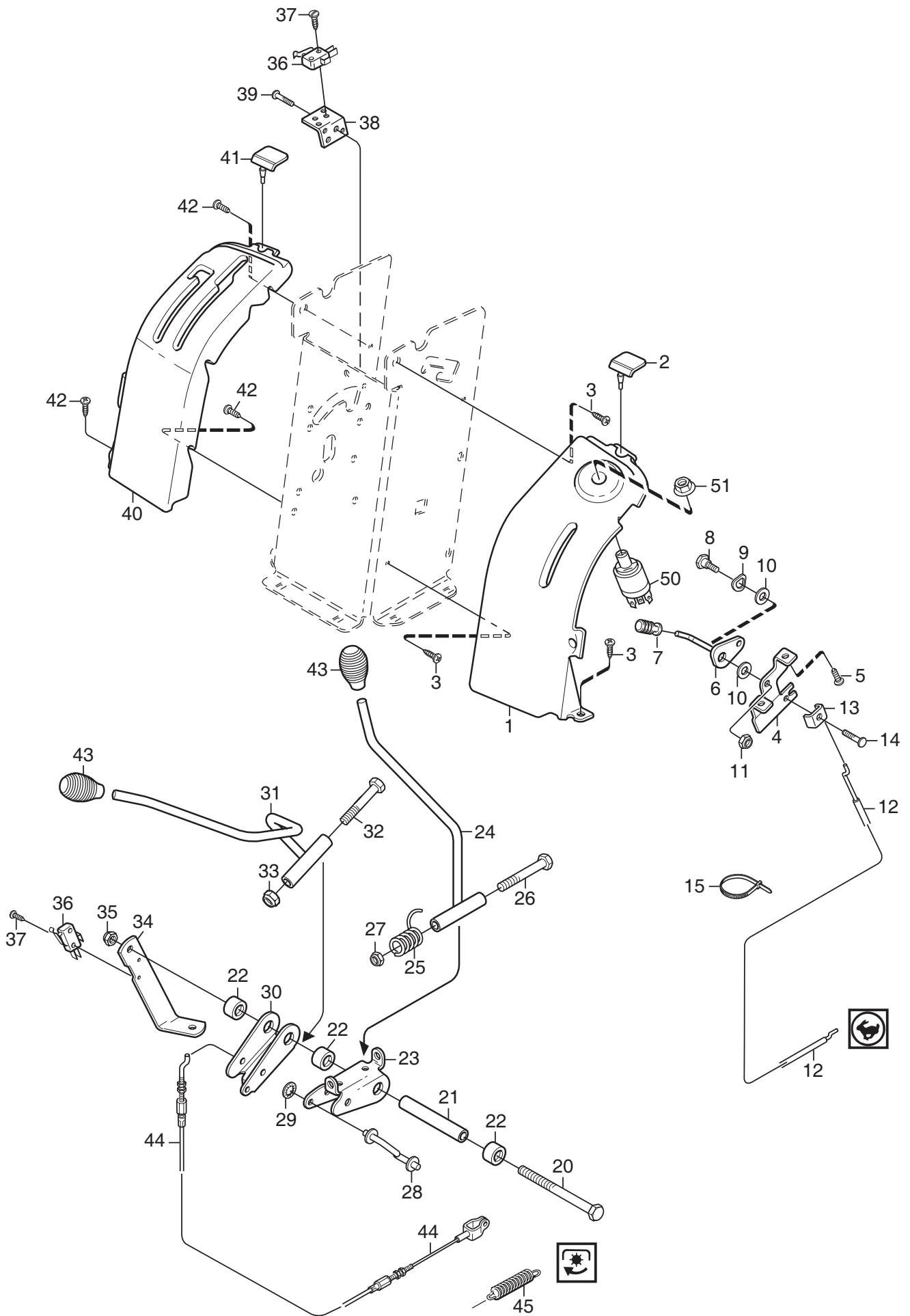

C073A

Ausgabe Issue 2011-31		Bild Nr Picture No C073A		XM 130 HANDBEDIENELEMENTE		XM 130 HAND CONTROLS		Seite Page 42	
Pos. Fig.	Anzahl/Quantity				Artikel Nr. Part No	Bezeichnung	Description	Satz Kit	Anmerkung Notes
	2781 -31 -91								
1	1				1134-5286-03	Regulierpanel- L.....	Control panel- LH.....		
2	2				1134-5531-01	Dämpfer.....	Absorber.....		
3	3				9893-0616-16	Schraube.....	Screw.....		
4	1				1134-5357-01	Halterung.....	Bracket.....		
5	2				9838-9516-12	Schraube.....	Screw.....		
6	1				1134-4077-01	Gasregulierung.....	Throttle control.....		
7	1				1134-5563-01	Knopf.....	Knob.....		
8	1				1134-0240-00	Ansatzbolzen.....	Shoulder screw.....		
9	1				9665-0002-00	Tellerscheibe.....	Bowed washer.....		
10	2				1134-4242-01	Distanzscheibe.....	Spacer washer.....		
11	1				9747-0831-02	Mutter.....	Lock nut.....		
12	1				1134-1597-13	Gasdraht.....	Throttle cable.....		
13	1				9500-9991-00	Drahtklemme.....	Cable clamp.....		
14	1				9943-0516-16	Schraube.....	Screw.....		
15	1				9579-0003-00	Kabelhalter.....	Cable holder.....		
20	1				9997-0812-02	Schraube.....	Screw.....		
21	1				1134-5274-02	Distanz.....	Spacer.....		
22	3				1134-3047-01	Distanz.....	Spacer.....		
23	1				1134-5271-01	Regulierhalterung.....	Control bracket.....		
24	1				1134-5275-01	Schalthebel.....	Gear shift lever.....		
25	1				1134-5535-01	Feder.....	Spring.....		
26	1				9997-0890-12	Schraube.....	Screw.....		
27	1				9747-0831-02	Mutter.....	Lock nut.....		
28	1				1134-5268-01	Schaltstange.....	Shifter rod.....		
29	1				9675-0009-02	Verriegelungsscheibe.....	Starlock.....		
30	1				1134-5271-01	Regulierhalterung.....	Control bracket.....		
31	1				1134-5276-01	Regulierhebel.....	Control lever.....		
32	1				9997-0890-12	Schraube.....	Screw.....		
33	1				9747-0831-02	Mutter.....	Lock nut.....		
34	1				1134-5356-01	Strebe.....	Strut.....		
35	1				9747-0831-02	Mutter.....	Lock nut.....		
36	2				9400-0360-01	Mikroschalter.....	Micro switch.....		
37	4				9840-7716-16	Schraube.....	Screw.....		
38	1				1134-5358-01	Schalhalterung.....	Switch bracket.....		
39	2				9943-0516-16	Schraube.....	Screw.....		
40	1				1134-5285-05	Regulierpanel- R.....	Control panel- RH.....		
41	2				1134-5531-01	Dämpfer.....	Absorber.....		
42	4				9893-0616-16	Schraube.....	Screw.....		
43	2				1134-5564-01	Regulierknopf.....	Control knob.....		
44	1				1134-3573-06	Nebenantriebsdraht.....	PTO cable.....		
45	1				1134-1242-02	Feder.....	Spring.....		
50	1				1134-4093-01	Zündschloß.....	Ignition switch.....		
51	1				1134-4749-01	Mutter.....	Nut.....		

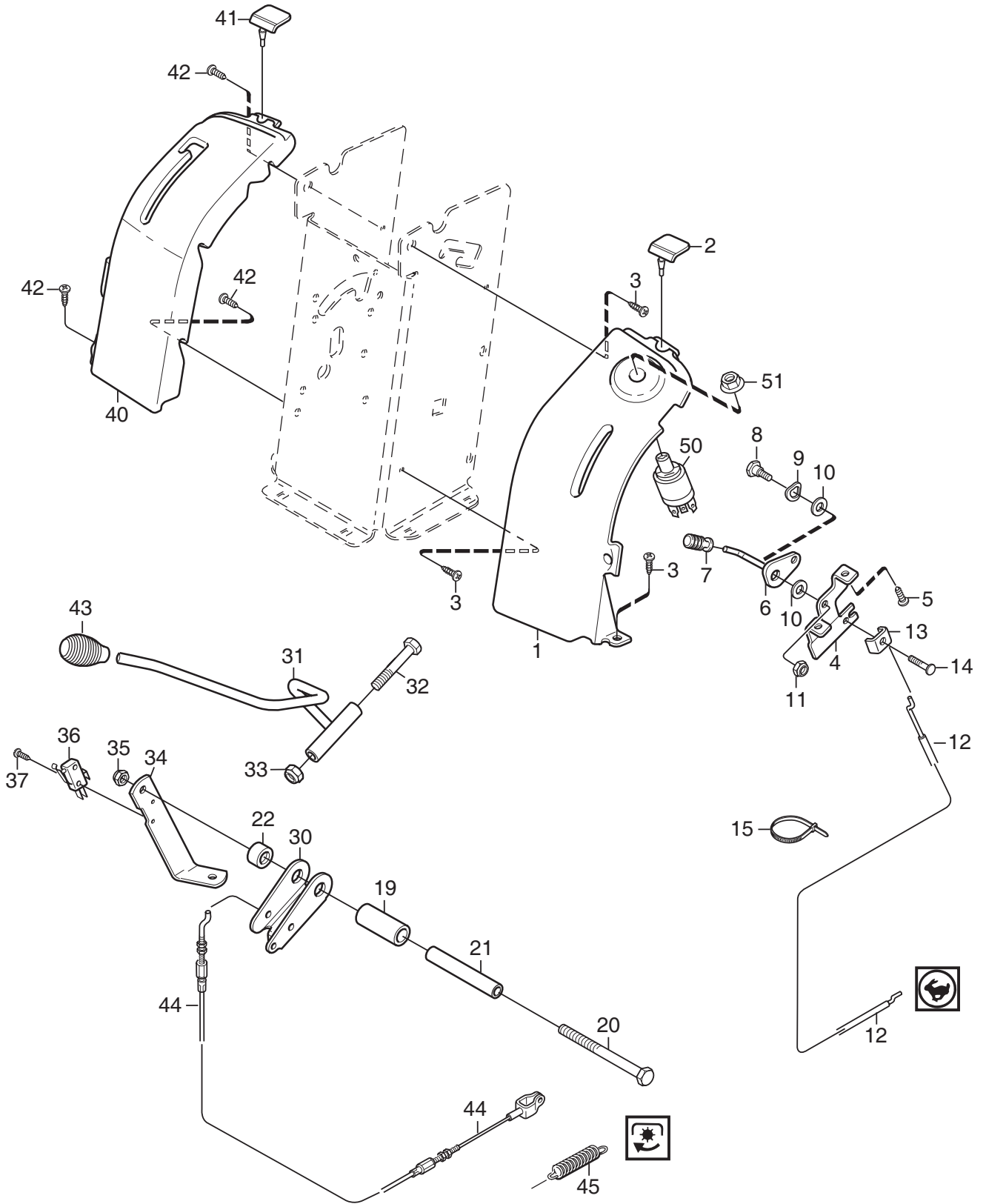

C074A

Ausgabe Issue		Bild Nr Picture No		XM 140 HD- XM 160 HD HANDBEDIENELEMENTE		XM 140 HD- XM 160 HD HAND CONTROLS		Seite Page	
2011-31		C074A						44	
Pos. Fig.	Anzahl/Quantity			Artikel Nr. Part No	Bezeichnung	Description	Satz Kit	Anmerkung Notes	
	2782 -30 -90	2783 -30 -90							
1	1	1		1134-5286-03	Regulierpanel- L.....	Control panel- LH.....			
2	2	2		1134-5531-01	Dämpfer.....	Absorber.....			
3	3	3		9893-0616-16	Schraube.....	Screw.....			
4	1	1		1134-5357-01	Halterung.....	Bracket.....			
5	2	2		9838-9516-12	Schraube.....	Screw.....			
6	1	1		1134-4077-01	Gasregulierung.....	Throttle control.....			
7	1	1		1134-5563-01	Knopf.....	Knob.....			
8	1	1		1134-0240-00	Ansatzbolzen.....	Shoulder screw.....			
9	1	1		9665-0002-00	Tellerscheibe.....	Bowed washer.....			
10	2	2		1134-4242-01	Distanzscheibe.....	Spacer washer.....			
11	1	1		9747-0831-02	Mutter.....	Lock nut.....			
12	1	1		1134-1597-13	Gasdraht.....	Throttle cable.....			
13	1	1		9500-9991-00	Drahtklemme.....	Cable clamp.....			
14	1	1		9943-0516-16	Schraube.....	Screw.....			
15	1	1		9579-0003-00	Kabelhalter.....	Cable holder.....			
19	1	1		1134-5508-01	Regulierhülse.....	Control sleeve.....			
20	1	1		9997-0812-02	Schraube.....	Screw.....			
21	1	1		1134-5274-02	Distanz.....	Spacer.....			
22	1	1		1134-3047-01	Distanz.....	Spacer.....			
30	1	1		1134-5271-01	Regulierhalterung.....	Control bracket.....			
31	1	1		1134-5276-01	Regulierhebel.....	Control lever.....			
32	1	1		9997-0890-12	Schraube.....	Screw.....			
33	1	1		9747-0831-02	Mutter.....	Lock nut.....			
34	1	1		1134-5356-01	Strebe.....	Strut.....			
35	1	1		9747-0831-02	Mutter.....	Lock nut.....			
36	1	1		9400-0360-01	Mikroschalter.....	Micro switch.....			
37	2	2		9840-7716-16	Schraube.....	Screw.....			
40	1	1		1134-5285-06	Regulierpanel- R.....	Control panel- RH.....			
41	2	2		1134-5531-01	Dämpfer.....	Absorber.....			
42	4	4		9893-0616-16	Schraube.....	Screw.....			
43	1	1		1134-5564-01	Regulierknopf.....	Control knob.....			
44	1	1		1134-3573-06	Nebenantriebsdraht.....	PTO cable.....			
45	1	1		1134-1242-02	Feder.....	Spring.....			
50	1	1		1134-4093-01	Zündschloß.....	Ignition switch.....			
51	1	1		1134-4749-01	Mutter.....	Nut.....			

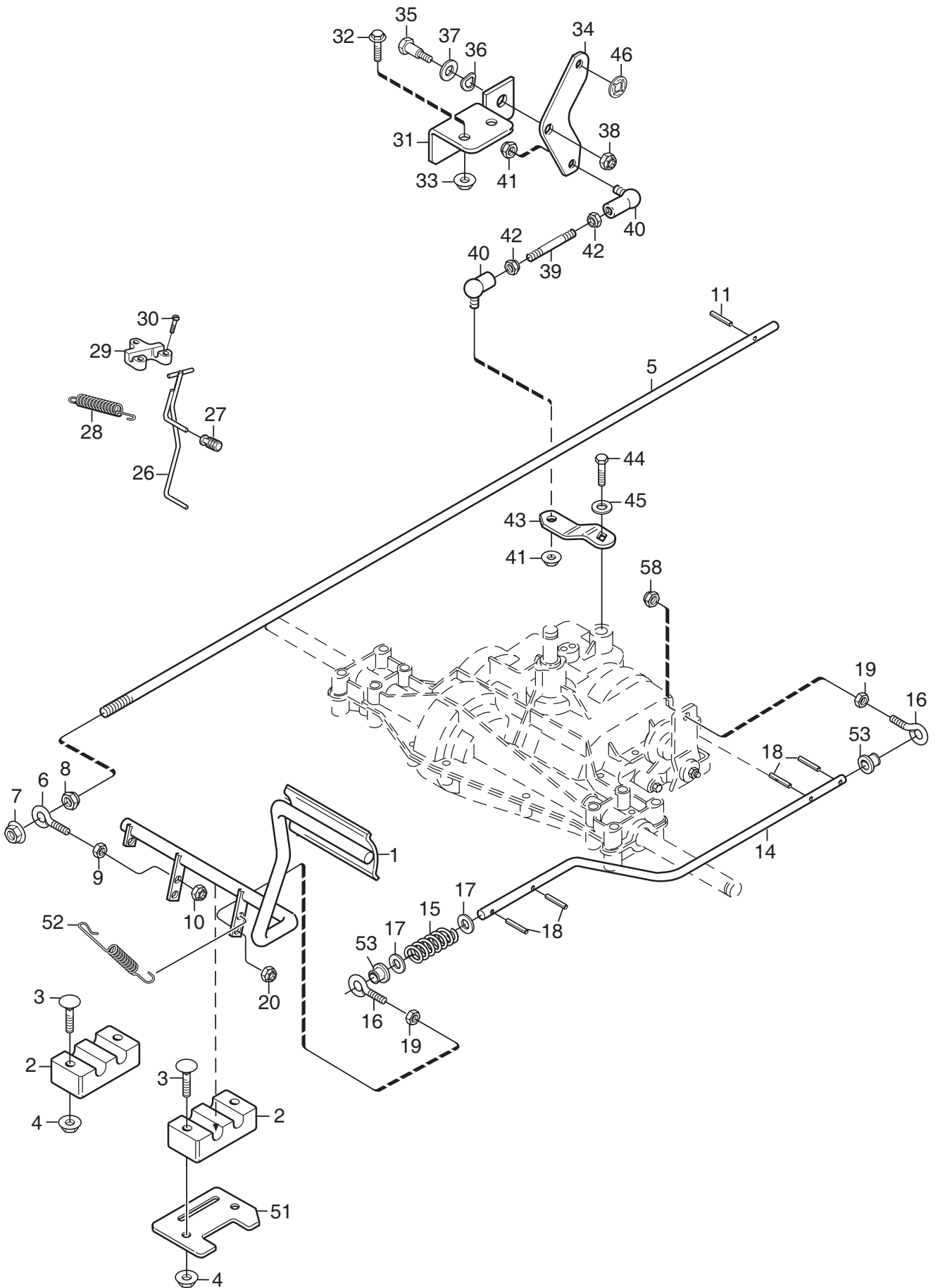

C075B

Ausgabe Issue 2011-31		Bild Nr Picture No C075B		XM 130 FUßBEDIENELEMENTE		XM 130 FOOT CONTROLS		Seite Page 46	
Pos. Fig.	Anzahl/Quantity				Artikel Nr. Part No	Bezeichnung	Description	Satz Kit	Anmerkung Notes
	2781 -31 -91								
1	1				1134-4802-01	Pedal	Pedal		
2	2				1134-4624-01	Lager	Bearing		
3	4				9897-0640-12	Schraube	Screw		
4	4				9739-0631-22	Mutter	Nut		
5	1				1134-4795-01	Kupplungsstange	Clutch rod		
6	1				1134-2138-01	Schrauböse	Eye bolt		
7	1				9739-1031-22	Mutter	Nut		
8	1				9731-1031-22	Mutter	Nut		
9	1				9739-0831-22	Mutter	Nut		
10	1				9747-0831-02	Mutter	Lock nut		
11	1				9595-0208-00	Spannstift	Locating pin		
14	1				1134-4777-01	Bremsstange	Brake rod		
15	1				1134-4617-01	Feder	Spring		
16	2				1134-2138-01	Schrauböse	Eye bolt		
17	2				9699-0035-02	Scheibe	Flat washer		
18	4				9595-0208-00	Spannstift	Locating pin		
19	2				9739-0831-22	Mutter	Nut		
20	1				9747-0831-02	Mutter	Lock nut		
26	1				1134-5353-01	Bremsstange	Brake rod		
27	1				1134-5566-01	Knopf	Knob		
28	1				1131-1497-01	Feder	Spring		
29	1				1134-4002-01	Halterung	Brake rod attachment		
30	3				9838-9516-12	Schraube	Screw		
31	1				1134-4714-01	Winkelhalterung	Angle bracket		
32	2				9959-0820-16	Schraube	Screw		
33	2				9739-0831-22	Mutter	Nut		
34	1				1134-4715-01	Dreieckenblech	Triangular plate		
35	1				1134-0240-00	Ansatzbolzen	Shoulder screw		
36	1				9694-0001-00	Scheibe	Washer		
37	1				9699-0036-02	Scheibe	Flat washer		
38	1				9747-0831-02	Mutter	Lock nut		
39	1				1134-4717-02	Gewindestange	Threaded rod		
40	2				9570-0004-00	Winkelgelenk	Elbow link		
41	2				9747-0631-02	Mutter	Lock nut		
42	2				9739-0631-22	Mutter	Nut		
43	1				1134-6351-01	Schaltarm	Shift lever		
44	1				9987-5016-16	Schraube	Screw		
45	1				9699-0060-02	Scheibe	Flat washer		
46	1				9675-0009-02	Verriegelungsscheibe	Starlock		
51	1				1134-4793-01	Halteblech	Stop plate		
52	1				4231-0013-00	Feder	Spring		
53	2				1134-4779-01	Plastikbuchse	Plastic bushing		
58	1				9747-0831-02	Mutter	Lock nut		

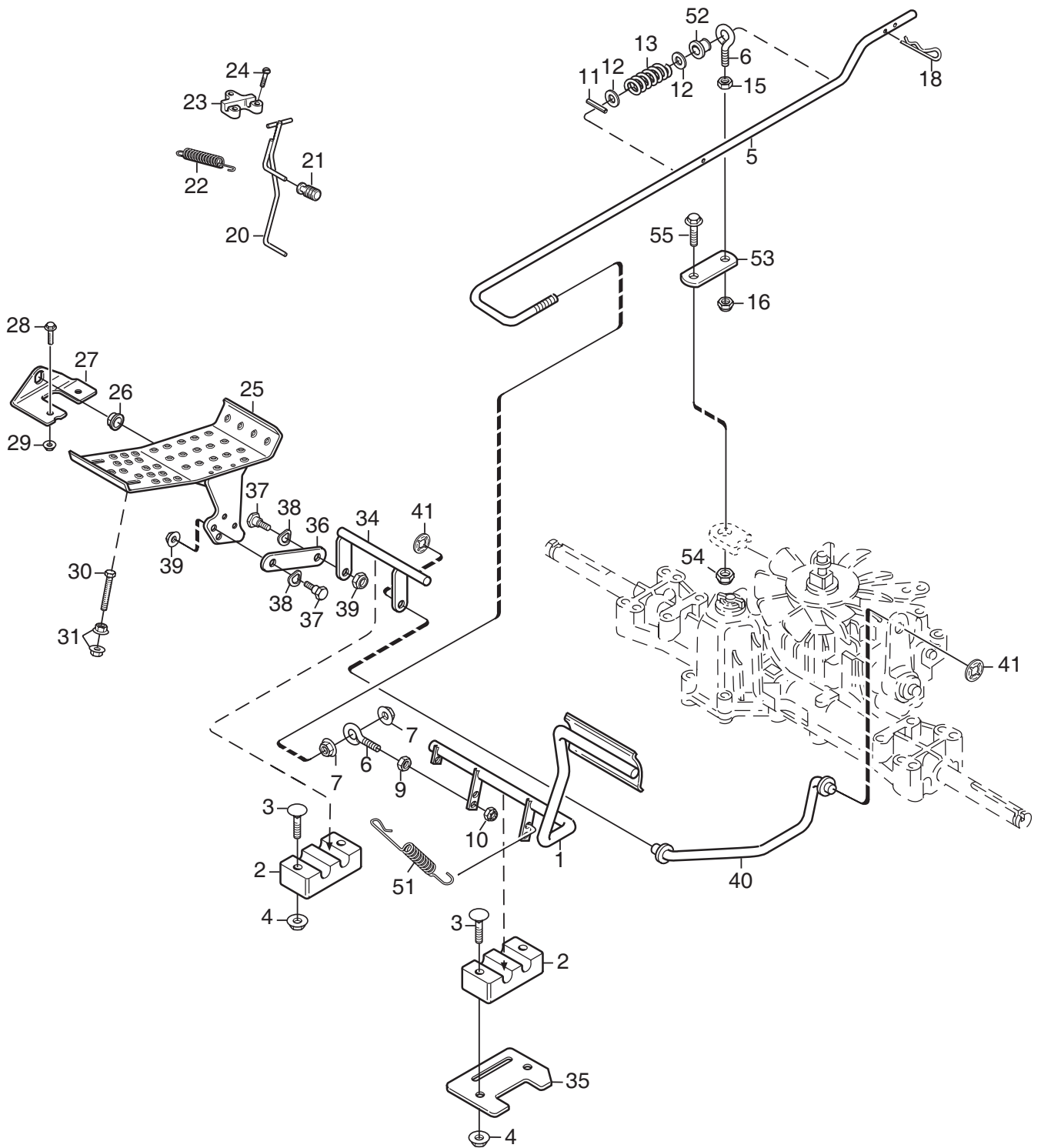

Ausgabe Issue 2011-31		Bild Nr Picture No C076B		XM 140 HD- XM 160 HD FUßBEDIENELEMENTE		XM 140 HD- XM 160 HD FOOT CONTROLS		Seite Page 48	
Pos. Fig.	Anzahl/Quantity			Artikel Nr. Part No	Bezeichnung	Description	Satz Kit	Anmerkung Notes	
	2782 -30 -90	2783 -30 -90							
1	1	1		1134-4802-01	Pedal	Pedal			
2	2	2		1134-4624-01	Lager	Bearing			
3	4	4		9897-0640-12	Schraube	Screw			
4	4	4		9739-0631-22	Mutter	Nut			
5	1	1		1134-4949-01	Kupplungsstange	Clutch rod			
6	2	2		1134-2138-01	Schrauböse	Eye bolt			
7	2	2		9739-1031-22	Mutter	Nut			
9	1	1		9739-0831-22	Mutter	Nut			
10	1	1		9747-0831-02	Mutter	Lock nut			
11	1	1		9595-0208-00	Spannstift	Locating pin			
12	2	2		9699-0035-02	Scheibe	Flat washer			
13	1	1		1134-4617-01	Feder	Spring			
15	1	1		9739-0831-22	Mutter	Nut			
16	1	1		9747-0831-02	Mutter	Lock nut			
18	1	1		9598-0002-02	Schließnadel	Pin lock			
20	1	1		1134-5353-01	Bremsstange	Brake rod			
21	1	1		1134-5566-01	Knopf	Knob			
22	1	1		1131-1497-01	Feder	Spring			
23	1	1		1134-4002-01	Halterung	Brake rod attachment			
24	3	3		9838-9516-12	Schraube	Screw			
25	1	1		1134-6353-01	Fahrpedal	Drive pedal			
26	2	2		1134-6313-01	Lager	Bearing			
27	2	2		1134-2700-01	Halter	Bracket			
28	2	2		9959-0820-16	Schraube	Screw			
29	2	2		9739-0831-22	Mutter	Nut			
30	1	1		9997-0860-16	Schraube	Screw			
31	2	2		9739-0831-22	Mutter	Nut			
34	1	1		1134-4440-01	Achse	Shaft			
35	1	1		1134-4793-01	Halteblech	Stop plate			
36	1	1		1134-4441-01	Gelenk	Link			
37	2	2		1134-0240-00	Ansatzbolzen	Shoulder screw			
38	2	2		9694-0001-00	Scheibe	Washer			
39	2	2		9747-0831-02	Mutter	Lock nut			
40	1	1		1134-5288-01	Regulierstange	Control rod			
41	2	2		9675-0012-02	Verriegelungsscheibe	Locking washer			
51	1	1		4231-0013-00	Feder	Spring			
52	1	1		1134-4779-01	Plastikbuchse	Plastic bushing			
53	1	1		1134-4972-01	Bremsgelenk	Brake link			
54	1	1		9747-0831-02	Mutter	Lock nut			
55	1	1		9997-0820-16	Schraube	Screw			

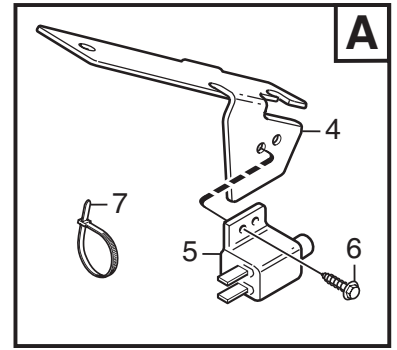
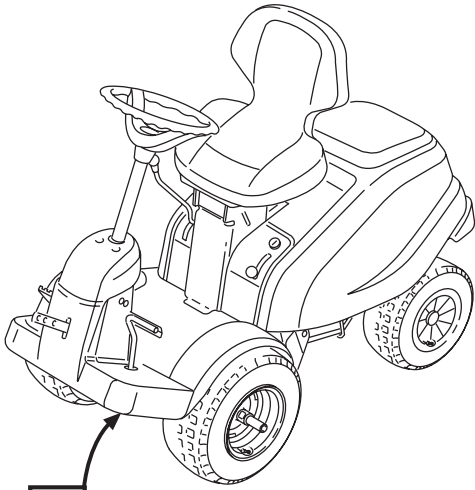

A

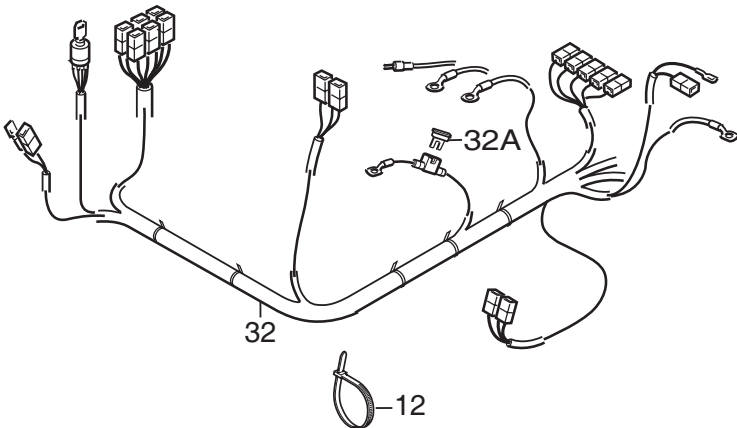
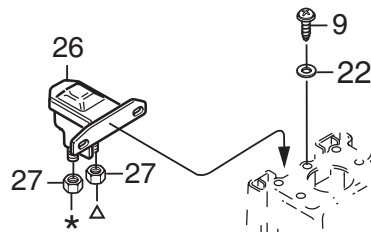
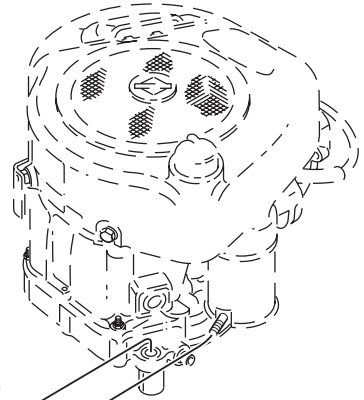
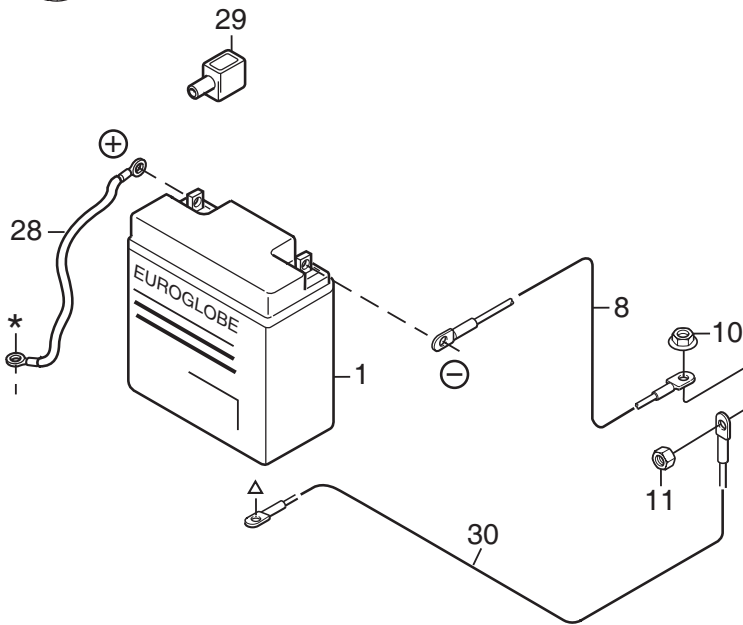

C077B

Ausgabe Issue 2011-31		Bild Nr Picture No C077B		XM 130 XM 140 HD- XM 160 HD EL. AUSSTATTUNG		XM 130 XM 140 HD- XM 160 HD ELECTRIC EQUIPMENT		Seite Page 50	
Pos. Fig.	Anzahl/Quantity			Artikel Nr. Part No	Bezeichnung	Description	Satz Kit	Anmerkung Notes	
	2781 -31 -91	2782 -30 -90	2783 -30 -90						
1	1	1	1	1134-4804-01	Batterie	Battery		18 Ah	
4		1	1	1134-4610-01	Schalthalterung	Switch bracket			
5		1	1	1134-3399-02	Schalter	Switch			
6		2	2	9852-8013-16	Schraube	Screw			
7		3	3	9579-0003-00	Kabelhalter.....	Cable holder			
8	1	1	1	1134-2042-02	Kabel- schwarz	Cable- black.....		L = 350 mm	
9	1	1	1	9838-9516-12	Schraube	Screw			
10	1	1	1	9747-0831-02	Mutter	Lock nut			
11	1	1	1	9795-3531-02	Mutter	Nut		1/4" UNC	
12	3	3	3	9579-0003-00	Kabelhalter.....	Cable holder			
22	1	1	1	9699-0060-02	Scheibe.....	Flat washer.....			
26	1	1	1	1134-3901-01	Magnetschalter	Solenoid			
27	2	2	2	9794-5131-02	Mutter	Nut			
28	1	1	1	1134-0234-02	Batteriekabel (+)	Battery cable (+).....		L = 395 mm	
29	1	1	1	1134-2310-01	Schutzkappe	Guard cap			
30	1	1	1	1134-4702-02	Kabel- rot	Cable- red.....		L = 480 mm	
32		1	1	1134-5767-01	Kabelbündel.....	Harness.....			
32	1			1134-7218-01	Kabelbündel.....	Harness.....			
32A	1	1	1	1134-3496-06	• Sicherung	• Fuse		20A	

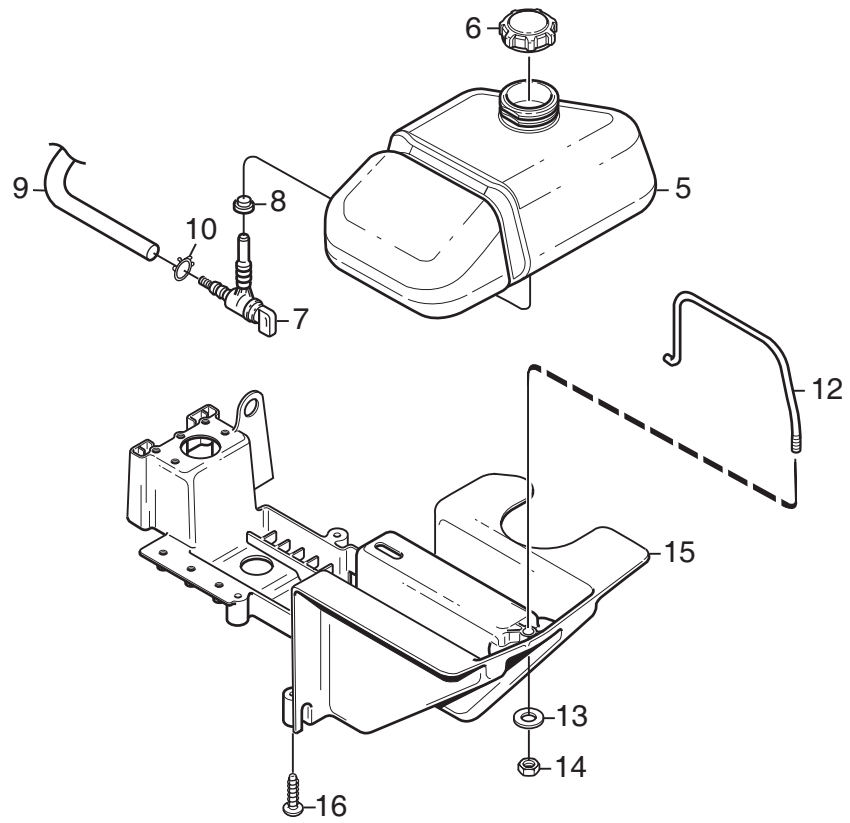
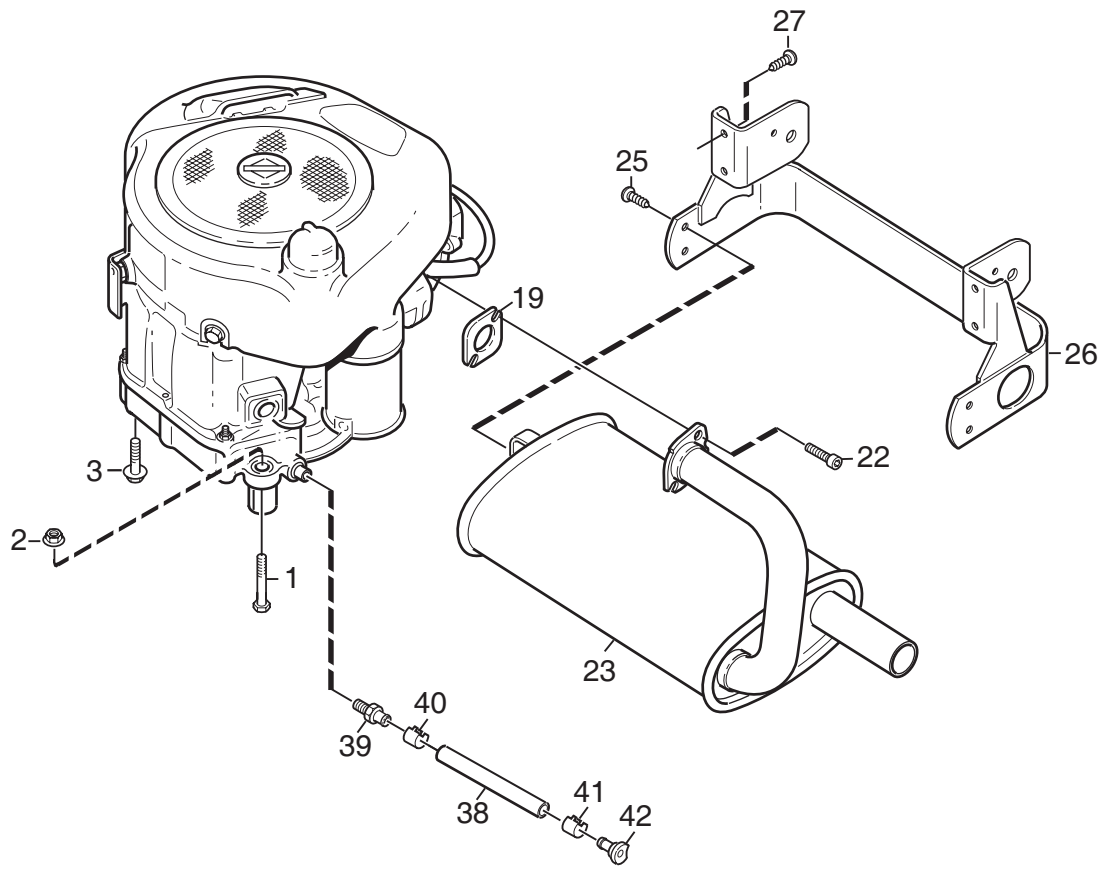

Ausgabe Issue		Bild Nr Picture No		XM 130 XM 140 HD- XM 160 HD MOTOR (B&S)		XM 130 XM 140 HD- XM 160 HD ENGINE (B&S)		Seite Page	
2011-31		1651C						52	
Pos. Fig.	Anzahl/Quantity			Artikel Nr. Part No	Bezeichnung	Description	Satz Kit	Anmerkung Notes	
	2781 -31 -91	2782 -30 -90	2783 -30 -90						
1	1	1	1	9997-0840-12	Schraube	Screw.....		M8 x 40	
2	1	1	1	9747-0831-02	Mutter.....	Lock nut.....			
3	3	3	3	9955-3725-16	Schraube	Screw.....		3/8" x 25	
5	1	1	1	1134-6626-01	Benzintank.....	Fuel tank.....			
6	1	1	1	1134-5532-01	Tankdeckel.....	Fuel tank cap.....			
7	1	1	1	1134-3224-01	Benzinhahn.....	Fuel shut-off valve.....			
8	1	1	1	1134-3225-01	Gummibuchse	Grommet.....			
9	0,51	0,46	0,46	9505-0001-01	Benzinschlauch.....	Fuel line (metre).....		Per Meter	
10	2	2	2	9578-0023-02	Schlauchklemme	Hose clamp.....			
12	1	1	1	1134-4808-01	Tankbügel	Tank clamp.....			
13	1	1	1	9699-0060-02	Scheibe.....	Flat washer.....			
14	1	1	1	9747-0631-02	Mutter	Lock nut.....			
15	1	1	1	1134-4807-02	Tank/Batterieregal.....	Tank/battery shelf.....			
16	4	4	4	9838-8822-19	Schraube	Screw.....			
19	1	1	1	1134-0433-00	Schalldämpferdichtung.....	Muffler gasket.....			
22	2	2	2	1134-4930-01	Schraube	Screw.....			
23			1	1134-7744-01	Schalldämpfer	Muffler			
23	1	1		1134-7781-01	Schalldämpfer	Muffler			
25	2	2	2	9893-0616-16	Schraube	Screw.....			
26	1	1	1	1134-6699-01	Wärmeschutz.....	Heat guard			
27	4	4	4	9893-0616-16	Schraube	Screw.....			
38	1	1	1	1134-5827-05	Ölablaß kpl.....	Oil drain assy.....		France only	
39	1	1	1	1134-5825-01	• Nippel	• Nipple.....			
40	1	1	1	9578-0023-04	• Schlauchklemme	• Hose clamp			
41	1	1	1	1134-3499-02	• Schlauchklemme	• Hose clamp			
42	1	1	1	1134-5826-01	• Propfen.....	• Plug.....			

X

Ausgabe Issue		Bild Nr Picture No		XM 130 TRANSMISSION	XM 130 TRANSMISSION	Seite Page			
2011-31		1643B				54			
Pos. Fig.	Anzahl/Quantity				Artikel Nr. Part No	Bezeichnung	Description	Satz Kit	Anmerkung Notes
	2781 -31 -91								
X	1	1			1137-0002-01	Motorriemenscheibe.....	Engine belt pulley.....		
	4	1			1134-6637-01	Riemenführung.....	Belt guide.....		
	5	1			9699-0056-02	Scheibe.....	Flat washer.....		
	6	1			1134-4519-01	Spannarm.....	Tension arm.....		
	7	1			1134-3053-01	Spannrolle.....	Tension roller.....		
	8	1			1134-4614-01	Ansatzdistanz.....	Shoulder spacer.....		
	9	1			9997-1040-16	Schraube.....	Screw.....		
	10	1			9699-0035-02	Scheibe.....	Flat washer.....		
	11	1			9739-1031-22	Mutter.....	Nut.....		
	12	1			1134-2989-02	Spannrolle- grau.....	Tension roller- grey.....		
	13	1			1134-1795-01	Riemenbügel.....	Belt stirrup.....		
	14	1			9997-1040-16	Schraube.....	Screw.....		
	15	2			9699-0035-02	Scheibe.....	Flat washer.....		
	16	1			9739-1031-22	Mutter.....	Nut.....		
	17	1			9585-0124-01	Keilriemen.....	V- belt.....		Polyester
X	17	1			9585-0209-01	Keilriemen.....	V- belt.....		Kevlar
	18	1			1134-1565-08	Distanz.....	Spacer.....		
	19	1			9997-0870-16	Schraube.....	Screw.....		
	20	2			9699-0056-02	Scheibe.....	Flat washer.....		
	21	1			9739-0831-22	Mutter.....	Nut.....		
	22	1			1134-5214-01	Feder.....	Spring.....		
	23	1			1134-6338-01	Getriebe Kpl.....	Transaxle assy.....		Dana 6800-7
	24	4			9960-0860-12	Schraube.....	Screw.....		
	25	4			9747-0831-02	Mutter.....	Lock nut.....		
	26	1			1134-4687-01	Strebe.....	Strut.....		
	27	1			9945-0816-16	Schraube.....	Screw.....		
X	28	1			1137-0006-01	Riemenscheibe.....	Belt pulley.....		
	30	1			9650-0016-04	Seegersicherung.....	Lock ring.....		
	31	1			1134-4707-01	Riemenführung.....	Belt guide.....		
	32	1			9942-0820-16	Schraube.....	Screw.....		
	41	1			1134-2138-01	Schrauböse.....	Eye bolt.....		
	42	1			1134-4779-01	Plastikbuchse.....	Plastic bushing.....		
	43	1			9739-0831-22	Mutter.....	Nut.....		
	44	1			9747-0831-02	Mutter.....	Lock nut.....		

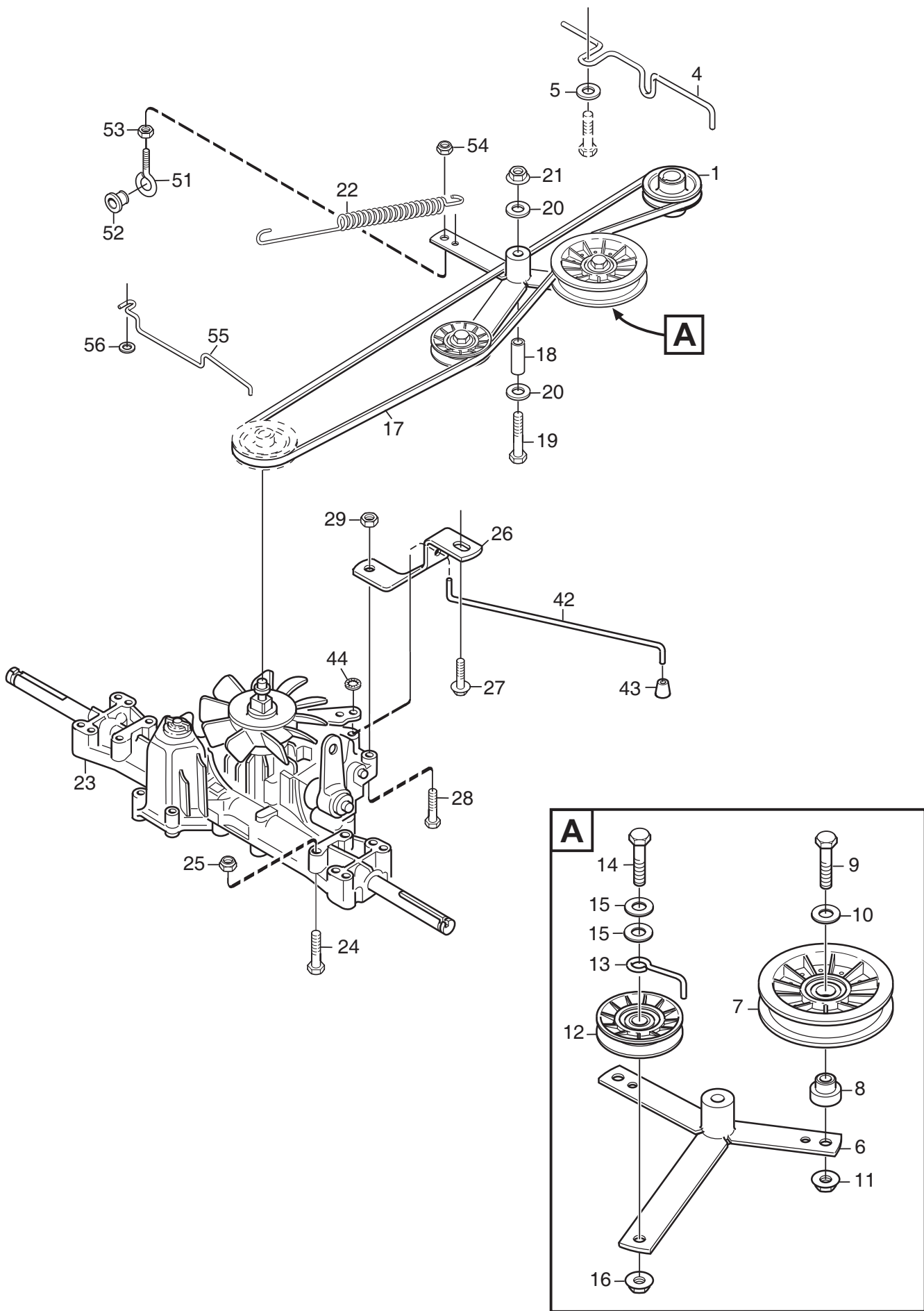

Ausgabe Issue		Bild Nr Picture No		XM 140 HD- XM 160 HD TRANSMISSION		XM 140 HD- XM 160 HD TRANSMISSION		Seite Page	
2011-31		1157G						56	
Pos. Fig.	Anzahl/Quantity			Artikel Nr. Part No	Bezeichnung	Description	Satz Kit	Anmerkung Notes	
	2782 -30 -90	2783 -30 -90							
X 1	1	1		1137-0002-01	Motorriemenscheibe.....	Engine belt pulley.....			
4	1	1		1134-6637-01	Riemenführung.....	Belt guide.....			
5	1	1		9699-0056-02	Scheibe.....	Flat washer.....			
6	1	1		1134-4519-01	Spannarm.....	Tension arm.....			
7	1	1		1134-3053-01	Spannrolle.....	Tension roller.....			
8	1	1		1134-4614-01	Ansatzdistanz.....	Shoulder spacer.....			
9	1	1		9997-1040-16	Schraube.....	Screw.....			
10	1	1		9699-0035-02	Scheibe.....	Flat washer.....			
11	1	1		9739-1031-22	Mutter.....	Nut.....			
12	1	1		1134-2989-02	Spannrolle- grau.....	Tension roller- grey.....			
13	1	1		1134-1795-01	Riemenbügel.....	Belt stirrup.....			
14	1	1		9997-1040-16	Schraube.....	Screw.....			
15	2	2		9699-0035-02	Scheibe.....	Flat washer.....			
16	1	1		9739-1031-22	Mutter.....	Nut.....			
17	1	1		9585-0099-01	Keilriemen.....	V- belt.....			
18	1	1		1134-1565-08	Distanz.....	Spacer.....			
19	1	1		9997-0870-16	Schraube.....	Screw.....			
20	2	2		9699-0056-02	Scheibe.....	Flat washer.....			
21	1	1		9739-0831-22	Mutter.....	Nut.....			
22	1	1		1134-5214-01	Feder.....	Spring.....			
23	1	1		1134-7766-01	Getriebe kpl.....	Transaxle assy.....		Kanzaki K46CJ	
24	4	4		9960-0860-12	Schraube.....	Screw.....			
25	4	4		9747-0831-02	Mutter.....	Lock nut.....			
26	1	1		1134-6290-01	Strebe.....	Strut.....			
27	1	1		9945-0816-16	Schraube.....	Screw.....			
28	1	1		9997-0840-12	Schraube.....	Screw.....			
29	1	1		9747-0831-02	Mutter.....	Lock nut.....			
42	1	1		1134-5156-01	Zugstange.....	Pull rod.....			
43	1	1		1134-4014-01	Plastikknopf.....	Plastic button.....			
44	1	1		9675-0009-02	Verriegelungsscheibe.....	Starlock.....			
51	1	1		1134-2138-01	Schrauböse.....	Eye bolt.....			
52	1	1		1134-4779-01	Plastikbuchse.....	Plastic bushing.....			
53	1	1		9739-0831-22	Mutter.....	Nut.....			
54	1	1		9747-0831-02	Mutter.....	Lock nut.....			
55	1	1		1134-5319-01	Riemenführung.....	Belt guide.....			
56	1	1		9699-0056-02	Scheibe.....	Flat washer.....			

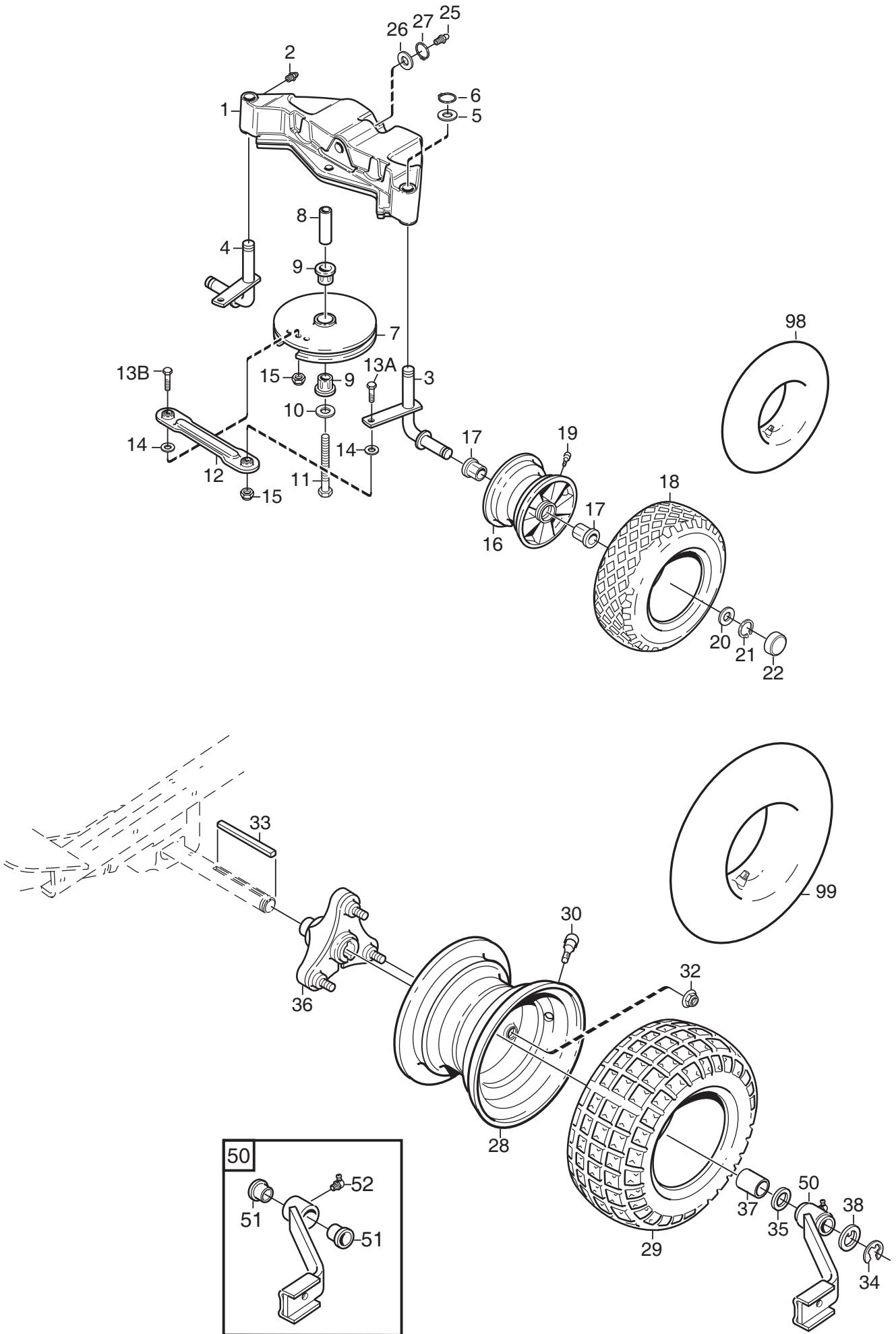

C081B

Ausgabe Issue 2011-31		Bild Nr Picture No C081B		XM 130 XM 140 HD- XM 160 HD RÄDER		XM 130 XM 140 HD- XM 160 HD WHEELS		Seite Page 58	
Pos. Fig.	Anzahl/Quantity			Artikel Nr. Part No	Bezeichnung	Description	Satz Kit	Anmerkung Notes	
	2781 -31 -91	2782 -30 -90	2783 -30 -90						
1	1	1	1	1134-6703-01	Hinterachse	Rear axle			
2	2	2	2	9501-0500-00	Schmiernippel	Grease joint			
3	1	1	1	1134-5009-02	Spindel- L	Spindle- LH			
4	1	1	1	1134-5009-01	Spindel- R	Spindle- RH			
5	2	2	2	9699-0088-02	Scheibe.....	Flat washer.....			
6	2	2	2	9650-0020-04	Seegersicherung.....	Circlip.....			
7	1	1	1	1137-0090-01	Lenkdrahtscheibe	Steering pulley			
8	1	1	1	1134-5575-01	Distanz.....	Spacer.....			
9	2	2	2	1134-0068-00	Lager	Bearing.....			
10	1	1	1	9699-0104-02	Scheibe.....	Washer.....			
11	1	1	1	9997-1680-12	Schraube	Screw.....			
12	2	2	2	1134-3247-05	Spurstange.....	Tie rod.....			
13A	2	2	2	9997-0825-16	Schraube	Screw.....		L = 25 mm	
13B	1	1	1	9997-0835-12	Schraube	Screw.....		L = 35 mm	
14	2	2	2	9699-0090-02	Scheibe.....	Flat washer.....			
15	3	3	3	9747-0831-02	Mutter.....	Lock nut.....			
16	2	2	2	1134-4706-01	Felge	Rim			
17	4	4	4	1134-1319-01	Lagerbuchse.....	Bearing bush.....			
18	2	2	2	9545-0117-00	Reifen	Tyre		13 x 5.00 - 6	
19	2	2	2	9545-0500-00	Ventil	Valve			
20	2	2	2	1134-0341-01	Scheibe.....	Washer.....			
21	2	2	2	9650-0020-04	Seegersicherung.....	Circlip.....			
22	2	2	2	1134-4344-01	Nabekapsel.....	Hub cap.....			
25	1	1	1	9501-0500-00	Schmiernippel	Grease joint.....			
26	1	1	1	9699-0088-02	Scheibe.....	Flat washer.....			
27	1	1	1	9650-0020-04	Seegersicherung.....	Circlip.....			
28	2	2	2	1134-5255-01	Felge	Rim			
29	2	2	2	9545-0126-01	Reifen	Tyre		16 x 6.00 - 8	
30	2	2	2	9545-0500-00	Ventil	Valve			
32	6	6	6	9731-1031-22	Mutter.....	Nut.....			
33	2	2	2	1134-2471-03	Keil	Key.....			
34	2	2	2	9653-0001-04	Schließring	Lock ring.....			
35	2	2	2	1134-0341-01	Scheibe.....	Washer.....			
36	2	2	2	1134-4844-02	Radnabe	Wheel hub.....			
37	2	2	2	1134-4845-02	Nabenhülse.....	Hub sleeve			
38	2	2	2	1134-4981-01	Scheibe.....	Washer.....			
50	2	2	2	1134-6274-01	Geräthalter kpl	Attachment assy			
51	2	2	2	1134-1319-01	• Lagerbuchse.....	• Bearing bush.....			
52	1	1	1	9501-0502-00	• Schmiernippel.....	• Grease joint.....			
98				9545-0204-00	Innenschlauch	Inner tube		Only as spare part	
99				9545-0203-00	Innenschlauch	Inner tube		Only as spare part	

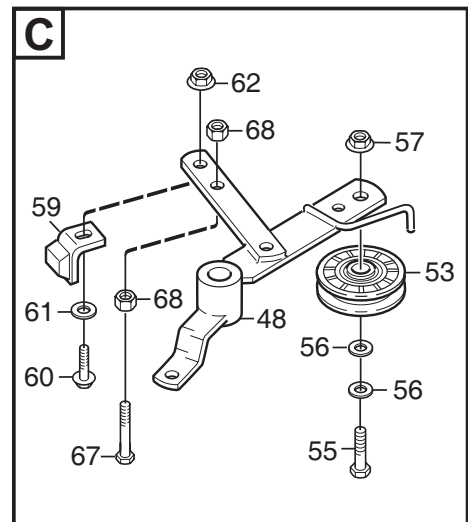
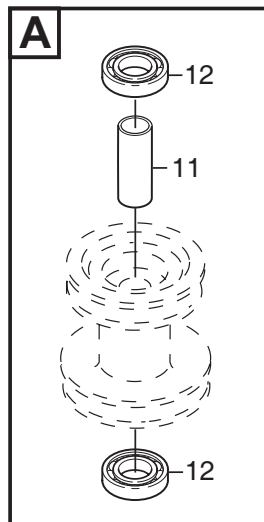
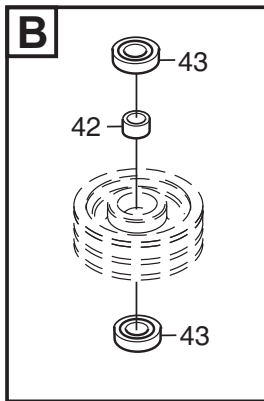
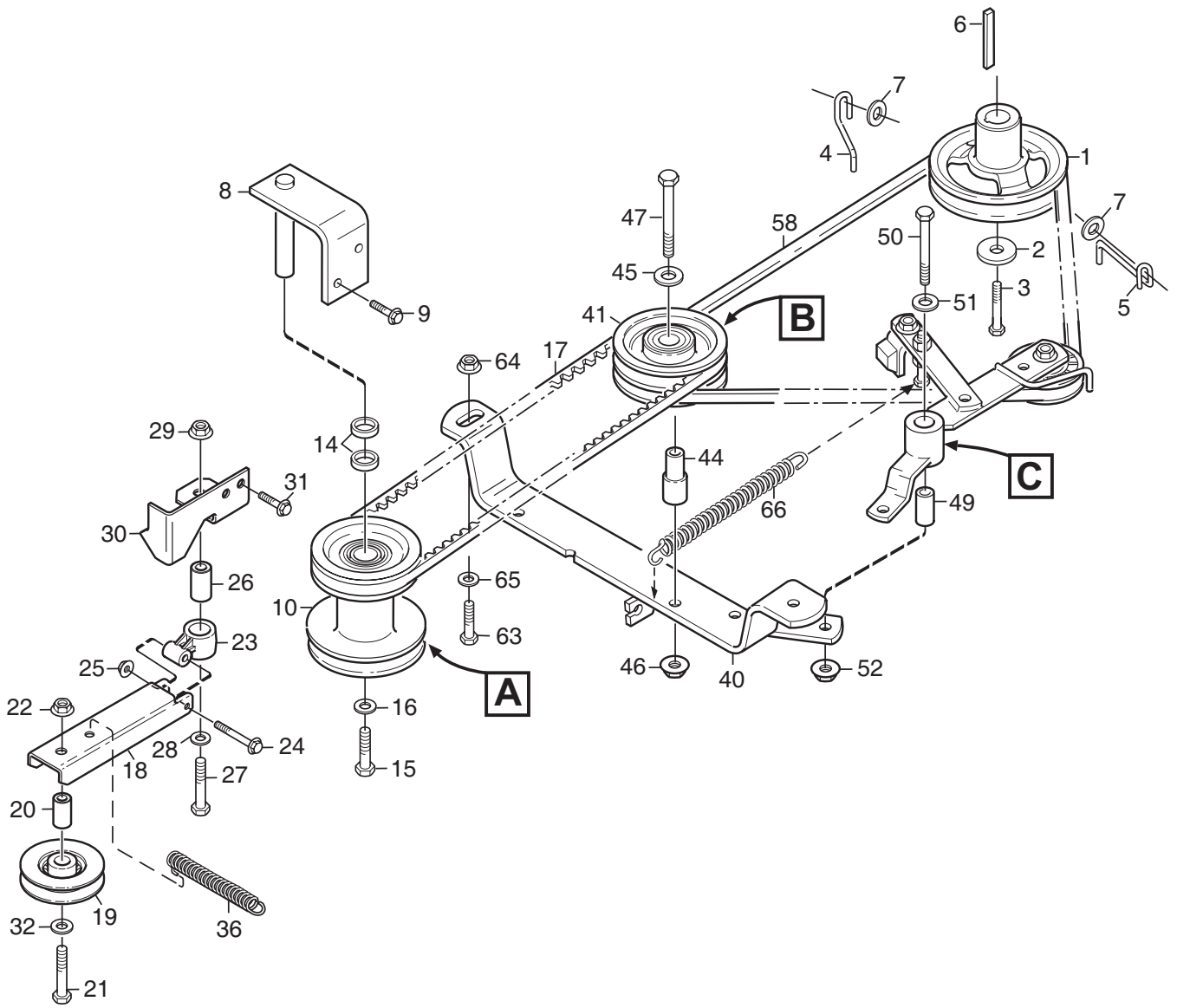

Ausgabe Issue 2011-31		Bild Nr Picture No 1512F			XM 130 XM 140 HD- XM 160 HD NEBENANTRIEB	XM 130 XM 140 HD- XM 160 HD POWER TAKE OFF	Seite Page 60		
Pos. Fig.	Anzahl/Quantity				Artikel Nr. Part No	Bezeichnung	Description	Satz Kit	Anmerkung Notes
	2781 -31 -91	2782 -30 -90	2783 -30 -90						
X	1	1	1	1	1137-0081-01	Motorriemenscheibe.....	Engine belt pulley.....		L = 2 1/2"
	2	1	1	1	1134-5017-01	Scheibe.....	Washer.....		
	3	1	1	1	9987-5332-16	Schraube.....	Screw.....		
	4	1	1	1	1134-5058-01	Riemenführung.....	Belt guide.....		
	5	1	1	1	1134-5057-01	Riemenführung.....	Belt guide.....		
	6	1	1	1	9600-0251-01	Keil.....	Key.....		
	7	2	2	2	9699-0056-02	Scheibe.....	Flat washer.....		
	8	1	1	1	1134-4650-01	Riemenscheibebügel.....	Pulley bracket.....		
	9	2	2	2	9945-0816-16	Schraube.....	Screw.....		
X	10	1	1	1	1137-0003-01	Riemenscheibe.....	Intermediate pulley.....		
	11	1	1	1	1134-0051-12	• Distanz.....	• Spacer.....		
	12	2	2	2	9549-0019-00	• Kugellager.....	• Ball bearing.....		
	14	2	2	2	1134-0052-00	Lagerdistanz.....	Bearing spacer.....		
	15	1	1	1	9997-1040-16	Schraube.....	Screw.....		
	16	1	1	1	9699-0035-02	Scheibe.....	Flat washer.....		
	17	1	1	1	9585-0139-01	Keilriemen.....	V- belt.....		
	18	1	1	1	1134-5231-01	Spannarm.....	Tension arm.....		
	19	1	1	1	1134-6329-01	Spannrolle.....	Tension roller.....		
	20	1	1	1	1134-4619-01	Distanz.....	Spacer.....		
	21	1	1	1	9997-1060-12	Schraube.....	Screw.....		
	22	1	1	1	9747-1031-02	Mutter.....	Lock nut.....		
	23	1	1	1	1134-6314-01	Halterung.....	Attachment.....		
	24	1	1	1	9997-0640-12	Schraube.....	Screw.....		
	25	1	1	1	9747-0631-02	Mutter.....	Lock nut.....		
	26	1	1	1	1134-4619-01	Distanz.....	Spacer.....		
	27	1	1	1	9930-1050-12	Schraube.....	Screw.....		
	28	1	1	1	9699-0035-02	Scheibe.....	Flat washer.....		
	29	1	1	1	9747-1031-02	Mutter.....	Lock nut.....		
	30	1	1	1	1134-4708-02	Halterung.....	Bracket.....		
	31	2	2	2	9945-0816-16	Schraube.....	Screw.....		
	32	1	1	1	9699-0035-02	Scheibe.....	Flat washer.....		
	36	1	1	1	1131-1507-00	Feder.....	Spring.....		
	40	1	1	1	1134-5037-01	Bügel.....	Bracket.....		
	41	1	1	1	1137-0004-01	Riemenscheibe kpl.....	Centre pulley assy.....		
	42	1	1	1	1134-0051-09	• Distanz.....	• Spacer.....		
	43	2	2	2	9549-0019-00	• Kugellager.....	• Ball bearing.....		
	44	1	1	1	1134-1839-02	Achse.....	Shaft.....		
	45	1	1	1	9699-0035-02	Scheibe.....	Flat washer.....		
	46	1	1	1	9739-1031-22	Mutter.....	Nut.....		
	47	1	1	1	9997-1070-12	Schraube.....	Screw.....		
X	48	1	1	1	1137-0144-01	Kupplungsarm.....	Clutch lever.....		Pos 42 - 43 incl.
	49	1	1	1	1134-1565-10	Distanz.....	Spacer.....		
	50	1	1	1	9997-0860-12	Schraube.....	Screw.....		
	51	1	1	1	9699-0056-02	Scheibe.....	Flat washer.....		
	52	1	1	1	9739-0831-22	Mutter.....	Nut.....		
	53	1	1	1	1134-2989-02	Spannrolle- grau.....	Tension roller- grey.....		
	55	1	1	1	9997-1035-16	Schraube.....	Screw.....		
	56	2	2	2	9699-0035-02	Scheibe.....	Flat washer.....		
	57	1	1	1	9739-1031-22	Mutter.....	Nut.....		
	58	1	1	1	9585-0204-01	Keilriemen.....	V- belt.....		
	59	1	1	1	1134-4164-03	Bremsklotz.....	Brake pad.....		
	60	1	1	1	9959-0820-16	Schraube.....	Screw.....		
	61	1	1	1	9699-0090-02	Scheibe.....	Flat washer.....		
	62	1	1	1	9747-0831-02	Mutter.....	Lock nut.....		
	63	2	2	2	9959-0820-16	Schraube.....	Screw.....		
	64	2	2	2	9739-0831-22	Mutter.....	Nut.....		
	65	1	1	1	9699-0056-02	Scheibe.....	Flat washer.....		
	66	1	1	1	1131-1506-00	Feder.....	Spring.....		
	67	1	1	1	9997-0860-12	Schraube.....	Screw.....		
	68	2	2	2	9739-0831-22	Mutter.....	Nut.....		