

120-A03

31-V EL EDV-NR.SA725

XX
XX
XX
XX
XX
XX

SECTIONAL INDEX
INDEX DE SECTION
GRUPPENINDEX
INDICE DELLA SEZIONE
INDICE DE GRUPOS
GRUPPSFORTECKNING

5- 10

SA003520 -UN-

5

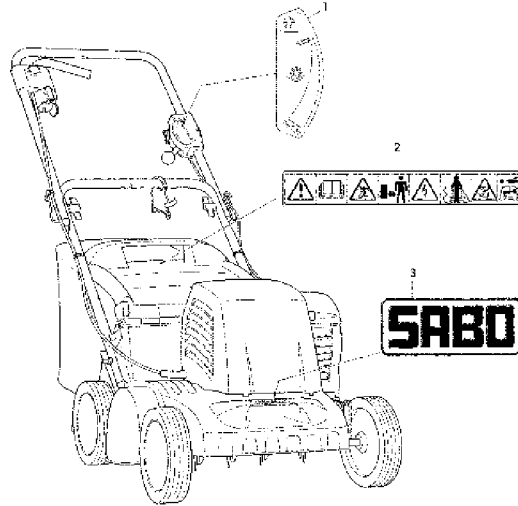

SA003525

SA003520

120-2

31-V EL EDV-NR.SA725

HOUSING, AXLE, WHEELS
CARTER, ESSIEU, ROUES
GEHAEUSE, ACHSE, RAEDER
SCATOLA, ASSALE, RUOTE
CARCASA, EJE, RUEDAS
HUS, AXEL, HJUL

SA003521 -UN-

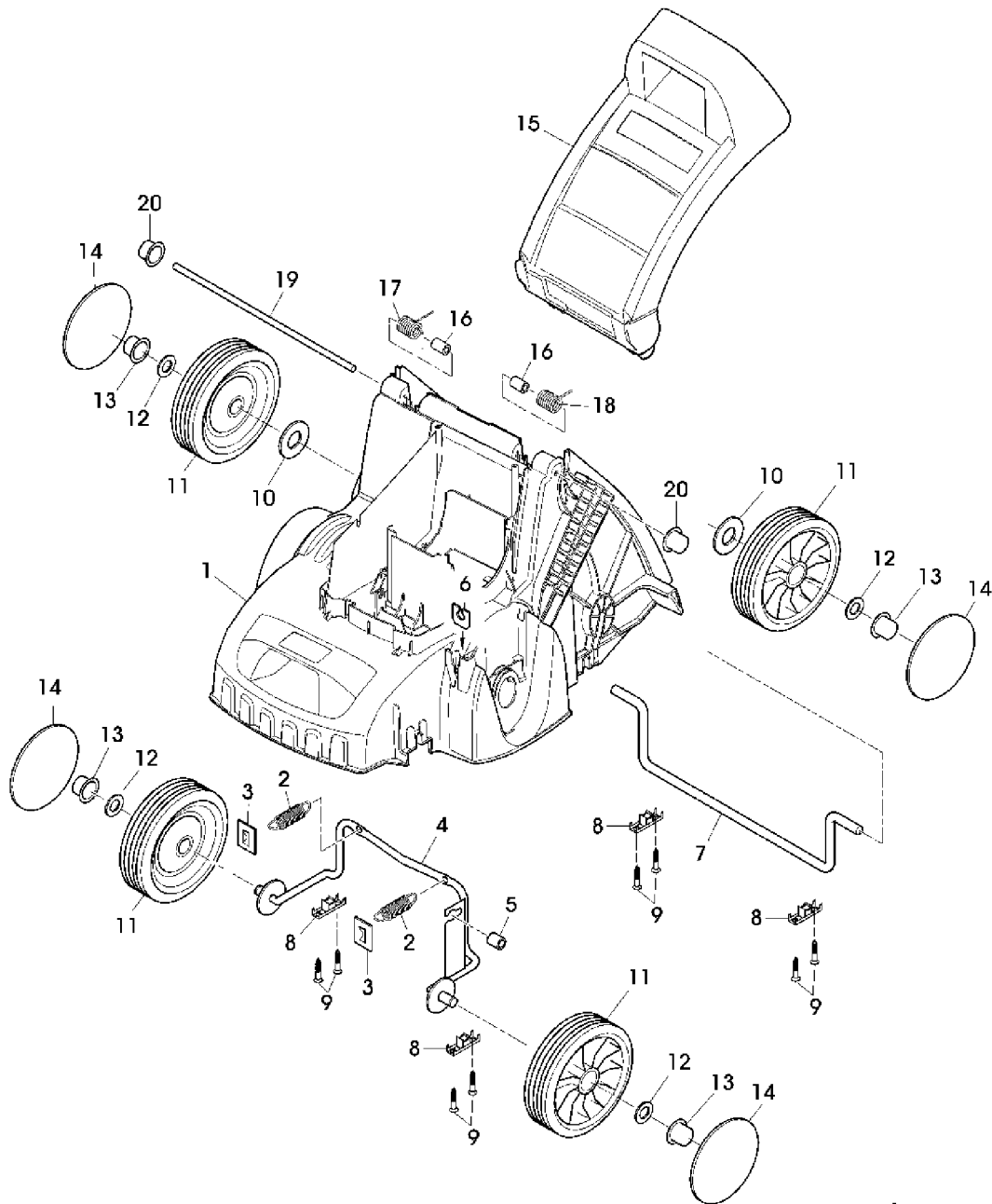

SA003521

120-3

31-V EL EDV-NR.SA725

TEIL	STCK.NR.	BEZEICHNUNG	STCK	SERIEN-NR.	S A 7 2 5	BEMERKUNGEN
1	SAA10010	GEHAEUSE	1		X	
2	SAU10078	ZUGFEDER	2		X	
3	SAU10044	HALTER	2		X	
4	SAU10037	VORDERACHSE	1		X	
5	SA12968	HUELSE	1		X	
6	SAU10043	HALTER	1		X	
7	SAU10038	HINTERACHSE	1		X	
8	SAU10039	KLEMME	4		X	
9	SA37450	SCHRAUBE	8		X	K 45X18
10	SA15220	UNTERLEGSCHIEBE	2		X	(A) A 10,5
11	SAU10077	RAD KPL. MIT BEREIFUNG	4		X	180MM
12	SA15205	UNTERLEGSCHIEBE	4		X	10,5
13	SA35203	FEDERKLEMME	4		X	D10
14	SA37314	DECKEL	4		X	
15	SAU10040	PRALLSCHUTZ	1		X	
16	SA36640	BUECHSE	2		X	
17	SA11397	FEDER	1		X	
18	SA31261	FEDER	1		X	
19	SAU10041	WELLE	1		X	
20	SA31710	FEDERKLEMME	2		X	(A) D6

(A) ONLY AVAILABLE AS PACKAGED SETS
 SEULEMENT DISPONIBLE EN LOTS
 WERDEN NUR NOCH IN PACKMENGEN GELIEFERT
 DISPONIBILI SOLO COME KIT
 SOLO SE OFRECE EN CONJUNTOS DE UNIDADES SUELTAS
 ENDAST FAERDIGPAKETERADE SATSER

120-4

31-V EL EDV-NR.SA725

BLADE SHAFT
ARBRE DE COUTEAU
MESSERWELLE
ALBERO LAMA
EJE DE CUCHILLAS
KNIVSPINDEL

SA003522 -UN-

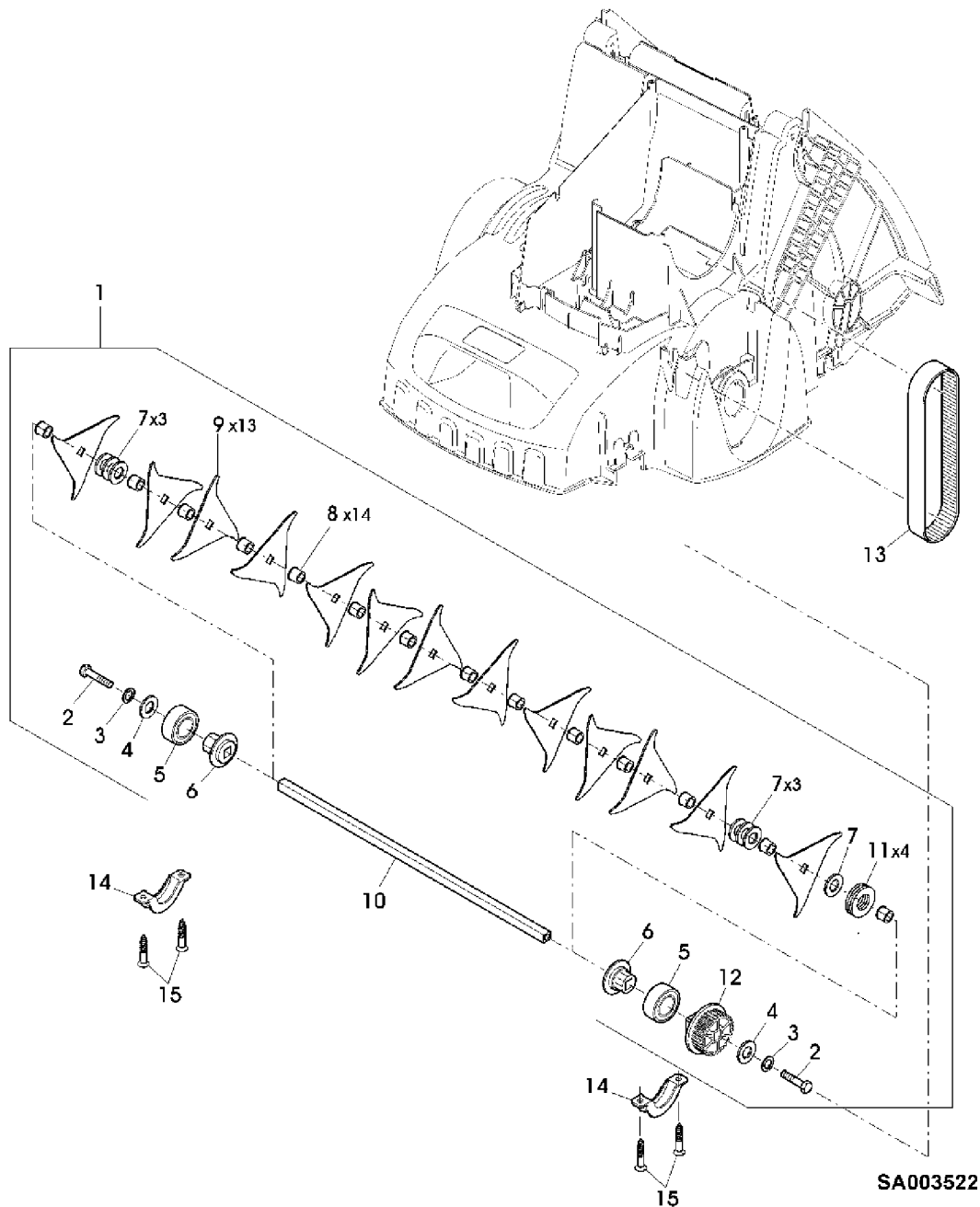

120-5

31-V EL EDV-NR.SA725

TEIL	STCK.NR.	BEZEICHNUNG	STCK	SERIEN-NR.	S A 7 2 5	BEMERKUNGEN
1	SAA10012	WELLE	1		X	ASSY, INCL KEYS 2,3,4,5,6,7,8,9,10,11,12
2	SAU10136	SECHSKANTSCHRAUBE	2		X	M8X25
3	SA15203	UNTERLEGSCHEIBE	2		X	8,4
4	SA16494	SCHEIBE	2		X	
5	SAU10086	KUGELLAGER	2		X	6005 2RS
6	SAU10050	ADAPTERANSCHLUESSE	2		X	
7	SA36978	SCHEIBE	7		X	20,2X28X1
8	SAU10049	BUECHSE	14		X	
9	SAU10048	MESSER	13		X	
10	SAU10047	WELLE	1		X	
11	SA30945	FEDERSCHEIBE	4		X	
12	SAU10052	RIEMENSCHLEIFE	1		X	
13	SAU10056	STEUERRIEMEN	1		X	
14	SAU10051	LAGERSCHALE	2		X	
15	SA30473	SCHRAUBE	4		X	K 70X18

120-6

31-V EL EDV-NR.SA725

ENGINE, DRIVE
MOTEUR, ENTRAINEMENT
MOTOR, ANTRIEB
MOTORE, COMANDO
MOTOR, ACCIONAMIENTO
MOTOR, DRIVNING

SA003714 -UN-

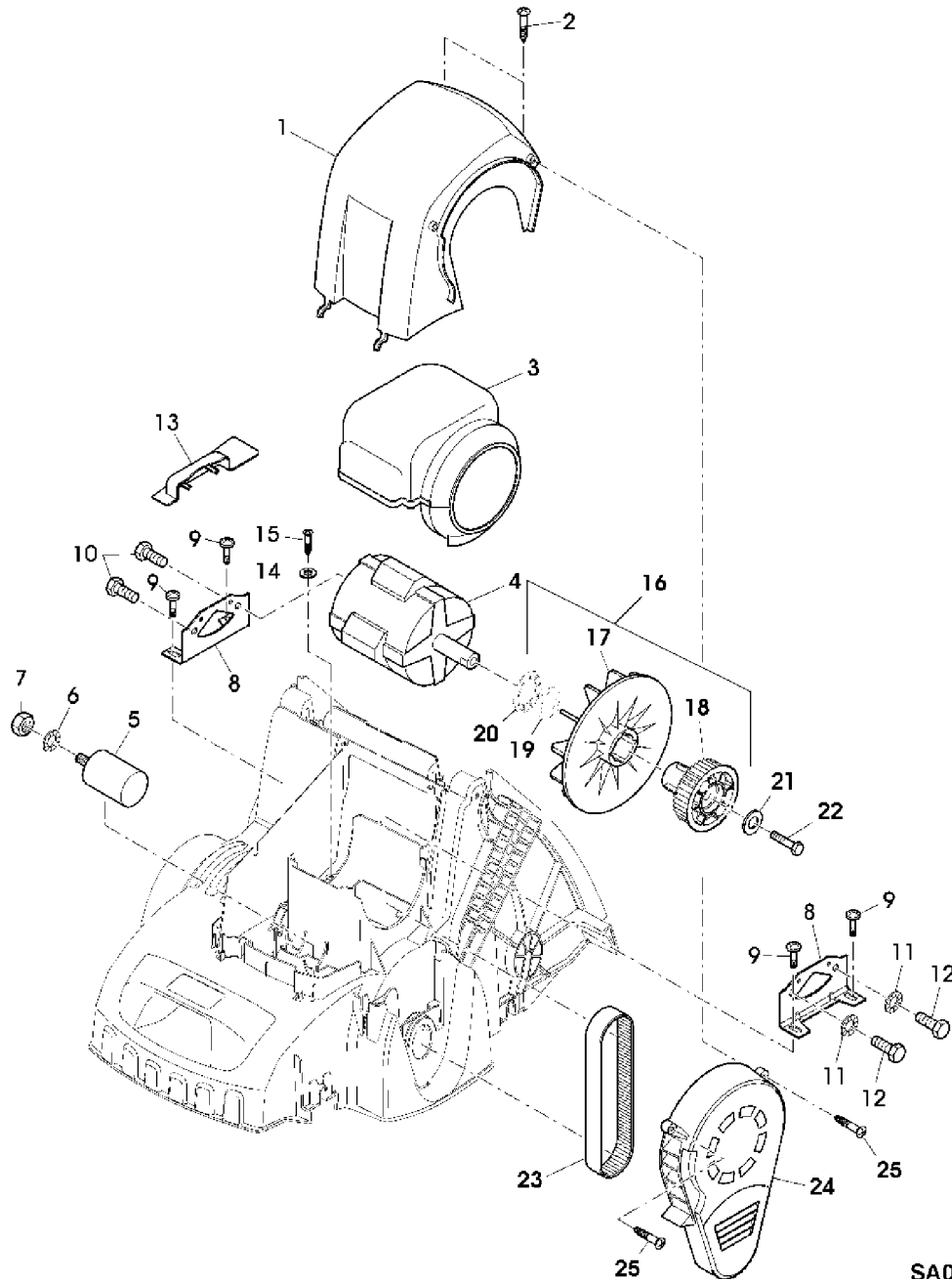

SA003714

120-7

31-V EL EDV-NR.SA725

TEIL	STCK.NR.	BEZEICHNUNG	STCK	SERIEN-NR.	S A 7 2 5	BEMERKUNGEN
1	SAU10059	HAUBE	1		X	
2	SA15882	SCHRAUBE	2		X	KB 50X20
3	SAU10058	LUEFTERHAUBE	1		X	
4	SAU10053	ELEKTROMOTOR	1		X	1400W (INCL KEY SAU10165)
5	SAU10165	KONDENSATOR	1		X	16UF
6	SA17244	SCHEIBE	1		X	A 8,4
7	SA15413	MUTTER	1		X	M8
8	SAU10057	HALTER	2		X	
9	SA30473	SCHRAUBE	4		X	K 70X18
10	SA17604	SCHRAUBE	2		X	(A)
11	SA35420	SCHEIBE	2		X	8,4
12	SA15329	SECHSKANTSCHRAUBE	2		X	M8X16
13	SAU10042	DECKEL	1		X	
14	SA15212	UNTERLEGSCHNEIBE	1		X	(A) A 6,4
15	SA31377	SCHRAUBE	1		X	KBL 50X14
16	SAA10096	RIEMENSCHNEIBE	1		X	ASSY, INCL KEYS 17, 18, 19, 20
17	LUEFTER	1		X	NSEP (ORD SAA10096)
18	RIEMENSCHNEIBE	1		X	NSEP (ORD SAA10096)
19	O-RING	1		X	NSEP (ORD SAA10096)
20	FEDERMUTTER	1		X	NSEP (ORD SAA10096)
21	SA15213	UNTERLEGSCHNEIBE	1		X	A 8,4
22	SAU10136	SECHSKANTSCHRAUBE	1		X	M8X25
23	SAU10056	STEUERRIEMEN	1		X	
24	SAU10060	DECKEL	1		X	
25	SA31377	SCHRAUBE	2		X	KBL 50X14

(A) ONLY AVAILABLE AS PACKAGED SETS
 SEULEMENT DISPONIBLE EN LOTS
 WERDEN NUR NOCH IN PACKMENGEN GELIEFERT
 DISPONIBILI SOLO COME KIT
 SOLO SE OFRECE EN CONJUNTOS DE UNIDADES SUELTAS
 ENDAST FAERDIGPAKETERADE SATSER

120-8

31-V EL EDV-NR.SA725

HANDLE, STARTER
GUIDE, DEMARREUR
FUEHRUNGSHOLM, STARTER
MANOPOLA, MOTORINO DI AVVIAMENTO
ASA PARA MANEJAR, MOTOR DE ARRANQUE
HANDTAG, STARTMOTOR
SA003524 -UN-

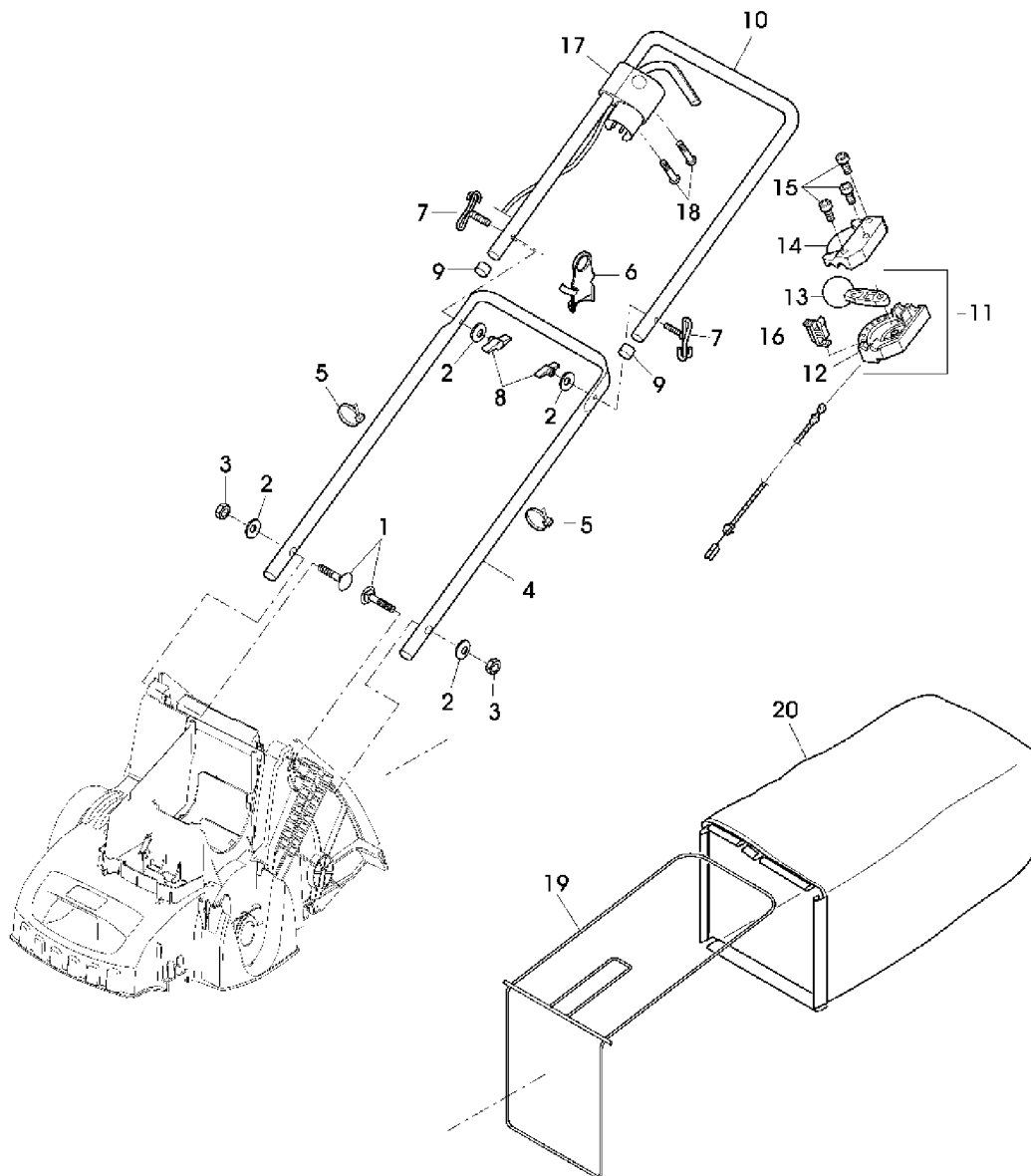

SA003524

120-9

31-V EL EDV-NR.SA725

TEIL	STCK.NR.	BEZEICHNUNG	STCK	SERIEN-NR.	S A 7 2 5	BEMERKUNGEN
1	SA15632	SCHRAUBE	2		X	M6X45
2	SA11243	UNTERLEGSCHIEBE	4		X	
3	SA11244	SICHERUNGSMUTTER	2		X	(A) M6
4	SAA10092	FUEHRUNG	1		X	LOW
5	SA12505	KABELBINDER	2		X	115MM
6	SA35998	KABELHALTER	1		X	
7	SAU10132	FUEHRUNG	2		X	
8	SA31121	FLUEGELMUTTER	2		X	(A)
9	SAU10135	ROHRSTOPFEN	2		X	
10	SAA10089	LENKSTANGE	1		X	UP
11	SAU10045	VERSTELLVORRICHTUNG	1		X	ASSY LOW, INCL KEYS 12,13
12	SAU10079	GEHAEUSE	1		X	LOW
13	SA34001	HEBEL	1		X	
14	SAU10084	DECKEL	1		X	UP
15	SA16268	SCHRAUBE	3		X	4X32
16	SAU10046	SEGMENT	1		X	
17	SAU10064	KABELBAUM, ELEKTROMOTOR-	1		X	
18	SA16267	SCHRAUBE	2		X	4,2X13
19	SAA10094	HALTER	1		X	
20	SAU10066	GRASFANGBEHAELTER	1		X	

(A) ONLY AVAILABLE AS PACKAGED SETS
 SEULEMENT DISPONIBLE EN LOTS
 WERDEN NUR NOCH IN PACKMENGEN GELIEFERT
 DISPONIBILI SOLO COME KIT
 SOLO SE OFRECE EN CONJUNTOS DE UNIDADES SUELTAS
 ENDAST FAERDIGPAKETERADE SATSER

120-10

31-V EL EDV-NR.SA725

DECALS
AUTOCOLLANTS
AUFKLEBER
CALCOMANIE
ADHESIVOS
DEKALER

SA003525 -UN-

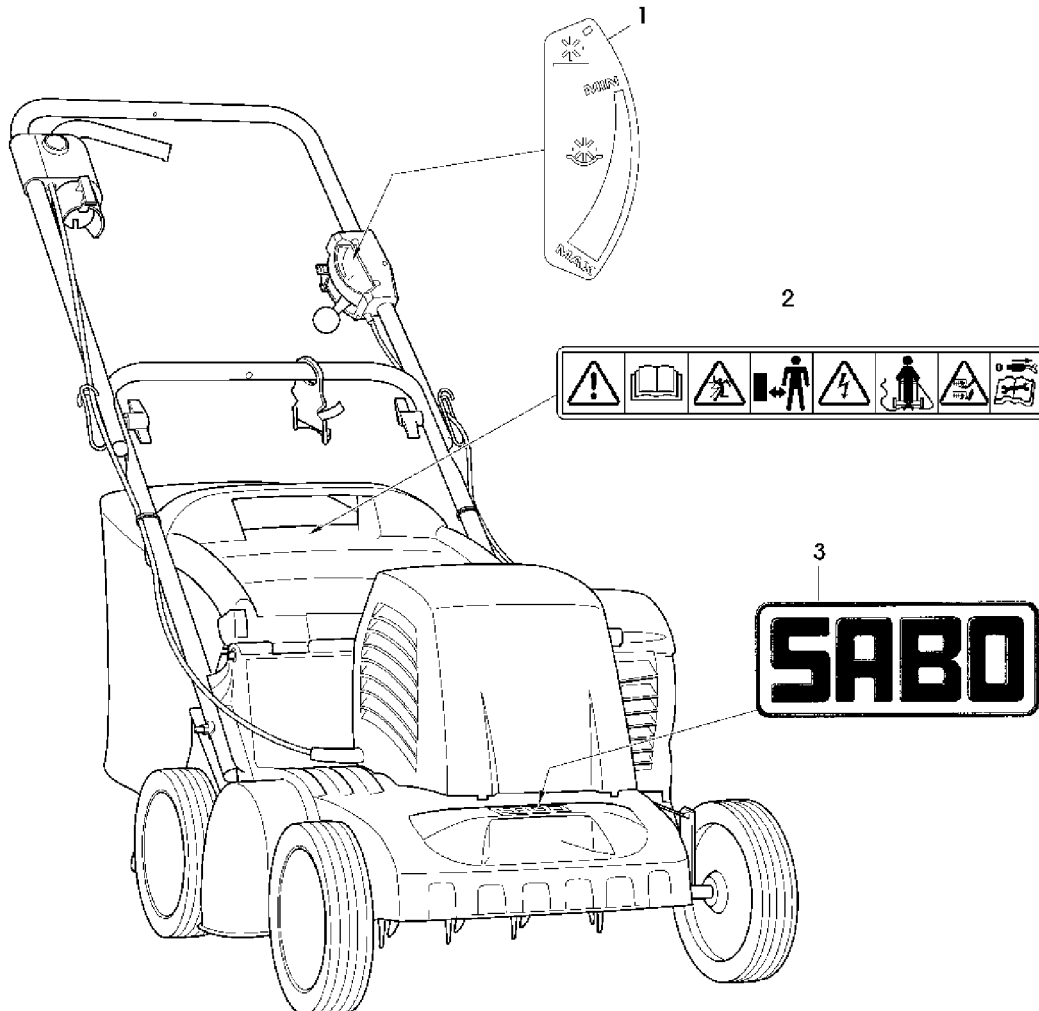

SA003525

120-11

31-V EL EDV-NR.SA725

TEIL	STCK.NR.	BEZEICHNUNG	STCK	SERIEN-NR.	S A 7 2 5	BEMERKUNGEN
1	SAU10085	AUFKLEBER	1		X	
2	SAU10119	AUFKLEBER	1		X	
3	SA37276	AUFKLEBER	1		X	