

BOSCH

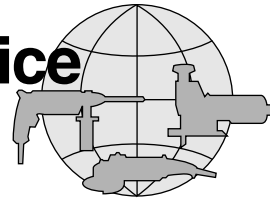

Service



EW / WJW 0 611 316 7 ..

(03 - 07)

X

INSTANDSETZUNGSHINWEISE
REPAIR INSTRUCTIONS
INSTRUCTIONS DE REPARATION
INSTRUCCIONES DE REPARACION

Schlaghammer
Demolition hammer
Marteau piqueur
Martillo de percusion

Typ 0 611 316 7 .. = GSH 10 E

Änderungen vorbehalten. Unsere Erzeugnisse werden stets dem neuesten technischen Stand angepaßt. Deshalb behalten wir uns Änderungen vor.

Modifications. Our products are constantly modified to meet new technical standards. We therefore reserve the right to alter data and specifications without prior notice.

Modifications. Nos produits sont continuellement adaptés aux dernières nouveautés techniques et les dates sont données sous réserve de changement.

Modificaciones. Nuestros fabricados van siendo adaptos constantemente a las últimas conquistas técnicas. Por ello, tenemos que reservarnos el derecho de introducir modificaciones en los datos técnicos.

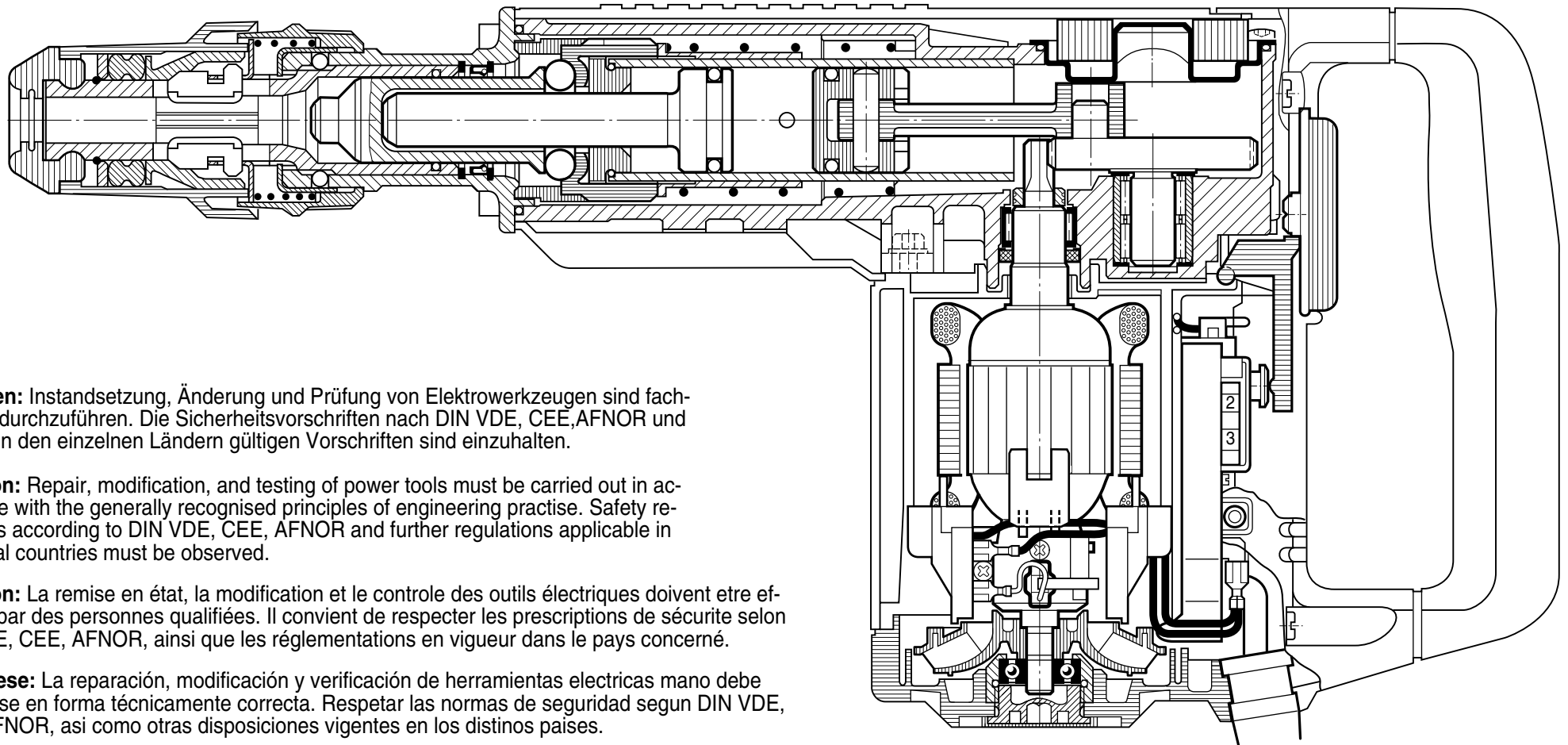

Beachten: Instandsetzung, Änderung und Prüfung von Elektrowerkzeugen sind fachgerecht durchzuführen. Die Sicherheitsvorschriften nach DIN VDE, CEE, AFNOR und weitere in den einzelnen Ländern gültigen Vorschriften sind einzuhalten.

Attention: Repair, modification, and testing of power tools must be carried out in accordance with the generally recognised principles of engineering practise. Safety regulations according to DIN VDE, CEE, AFNOR and further regulations applicable in individual countries must be observed.

Attention: La remise en état, la modification et le controle des outils électriques doivent être effectués par des personnes qualifiées. Il convient de respecter les prescriptions de sécurité selon DIN VDE, CEE, AFNOR, ainsi que les réglementations en vigueur dans le pays concerné.

Obsérvese: La reparación, modificación y verificación de herramientas electricas mano debe efectuarse en forma técnicamente correcta. Respetar las normas de seguridad segun DIN VDE, CEE, AFNOR, asi como otras disposiciones vigentes en los distinos paises.

ROBERT BOSCH GMBH GESCHÄFTSBEREICH ELEKTROWERKZEUGE D 70745 LEINFELDEN-ECHTERDINGEN



Zerlegen

Für die Demontage werden handelsübliche Werkzeuge benötigt.

1. Eingangsprüfung durchführen.
Beachten:
Die Sicherheitsvorschriften nach DIN, VDE, CEE, AFNOR und weitere in den einzelnen Ländern gültigen Vorschriften sind einzuhalten.

Disassembly

Use normal trade tools by disassembly.

1. Carry out power supply check.
Attention:
Safety regulations according to DIN, VDE, CEE, AFNOR and further regulations applicable in individual countries must be observed.

Démontage

Pour le démontage, des outils en usage dans le commerce sont nécessaires.

1. Effectuer un contrôle préliminaire.
Attention:
Respecter les instructions de sécurité selon DIN, VDE, CEE, AFNOR et les autres instructions valables dans les pays respectifs.

Desmontaje

Para el desmontaje no se precisan herramientas especiales.

1. Realizar control de recepción.
Atención:
Atenerse a las prescripciones de seguridad según DIN, VDE, CEE, AFNOR y a las prescripciones adicionales específicas que pudieran existir en los respectivos países.

1.

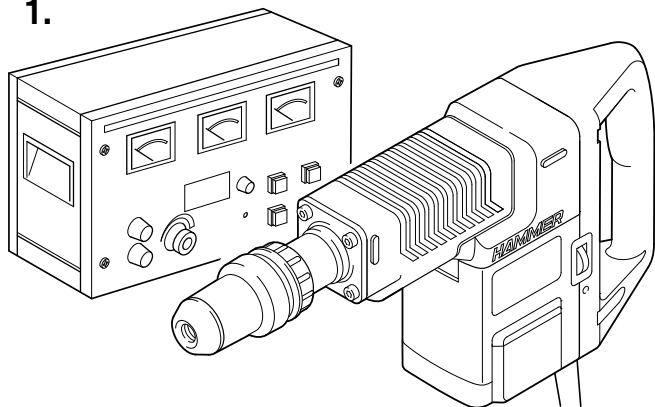

2.

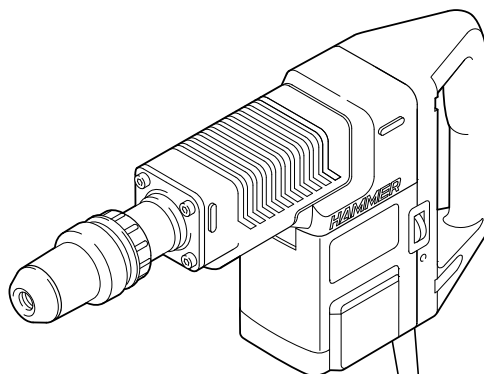

2. Zerlegen nach Explosions-, Schnittzeichnung und diesem Instandsetzungshinweis.
2. Disassembly using explosion, cut-away drawings and these repair instructions!
2. Démontez l'appareil suivant la vue éclatée, le plan en coupe et ces instructions de réparation.
2. Realizar el desmontaje conforme a los dibujos en perspectiva y en sección, y a estas instrucciones de reparación.

3.

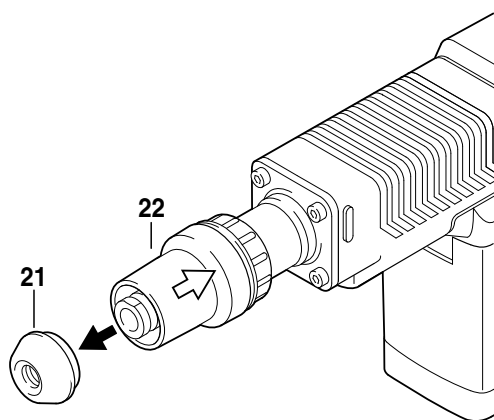

3.1

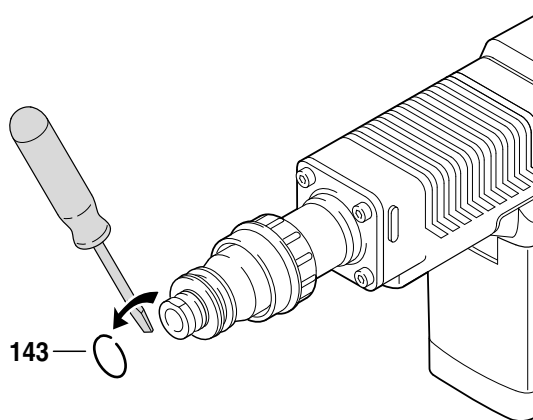

3.2

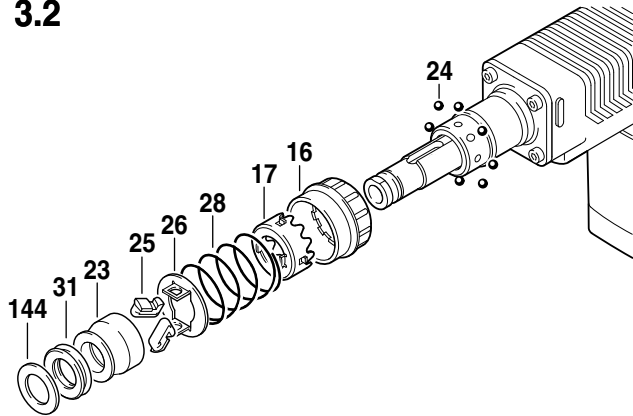

3.3

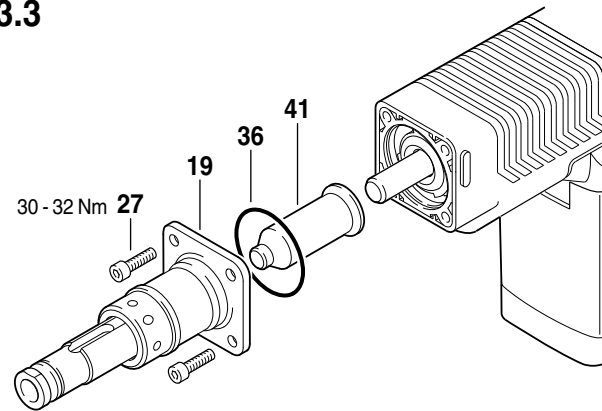

3.4

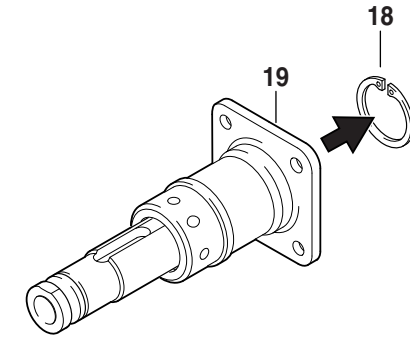

3.5

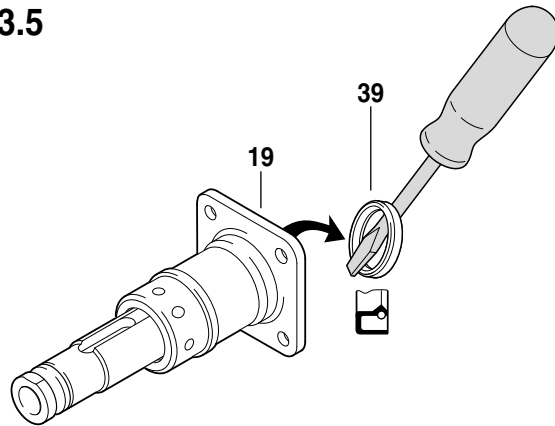

3.6

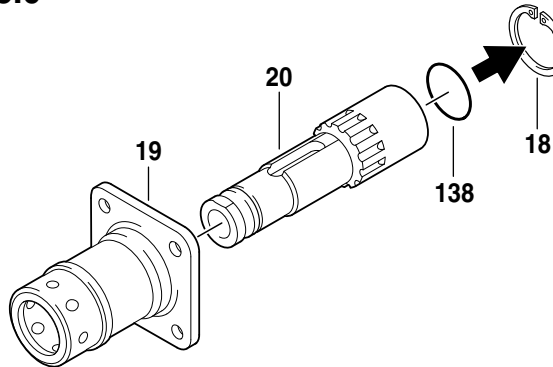

4.

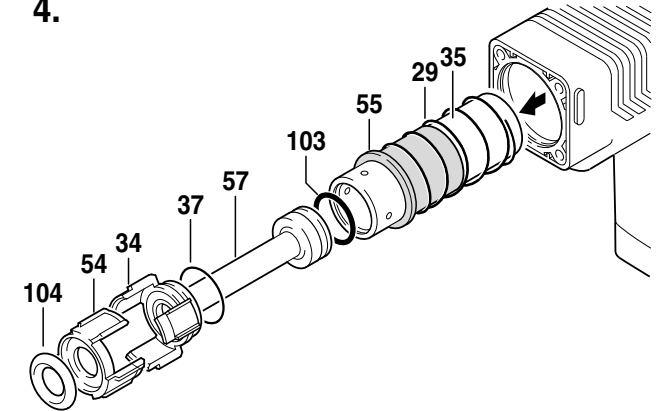

5.

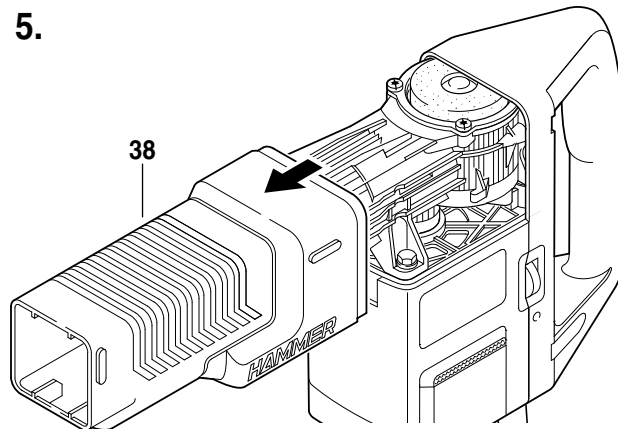

5.1

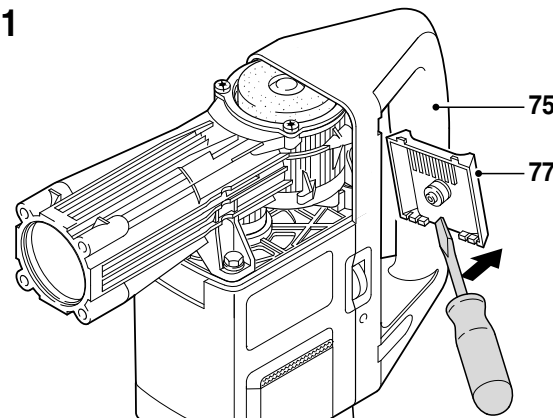

5.2

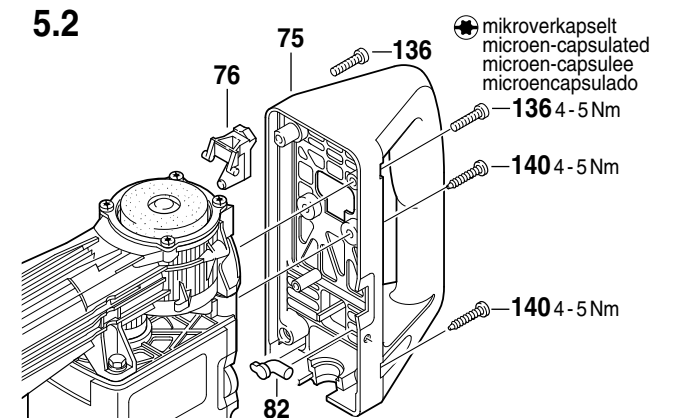

6.

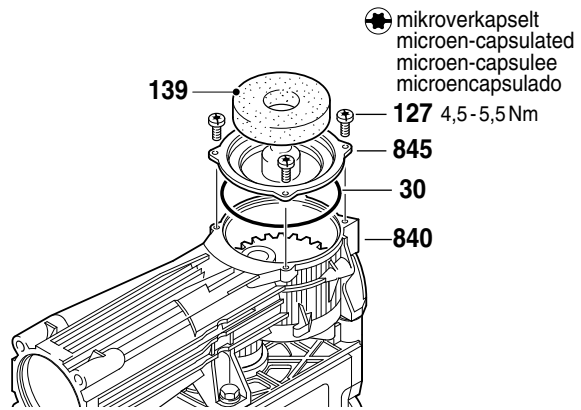

6.1

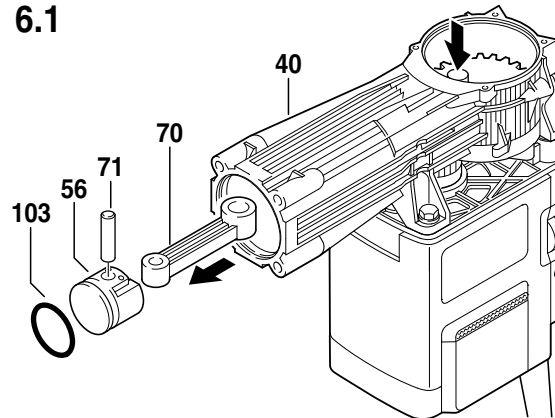

6.2

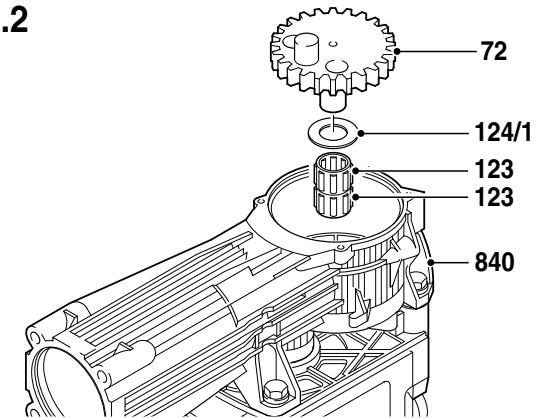

6.3

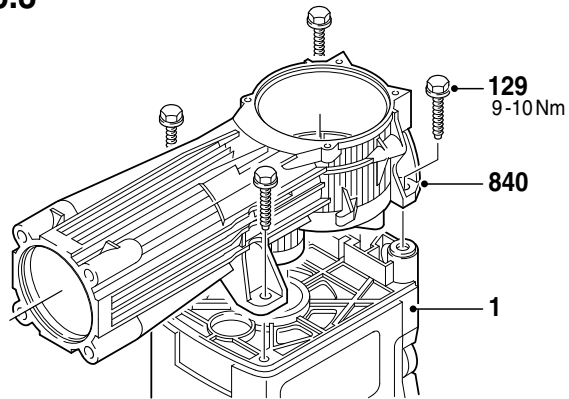

6.4

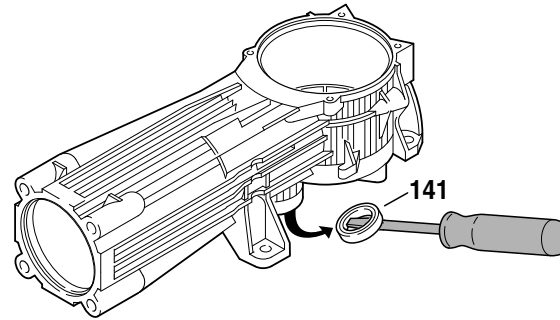

6.5

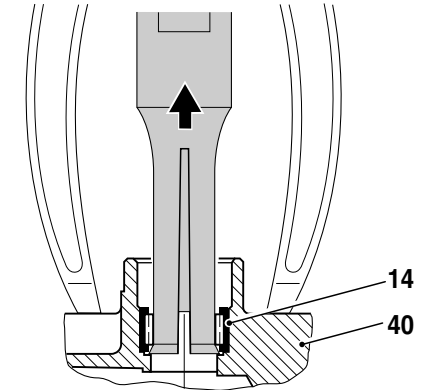

7.

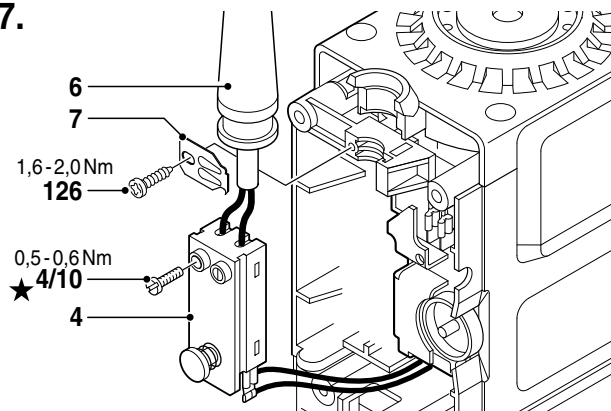

7.1

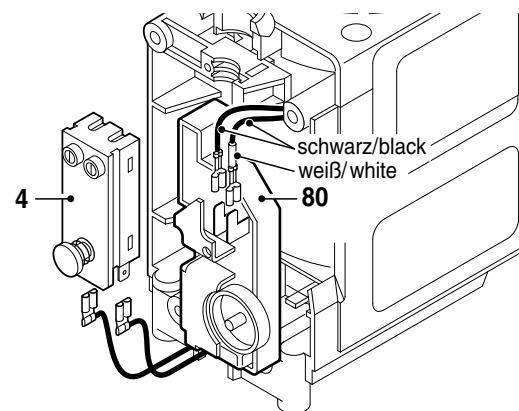

8.

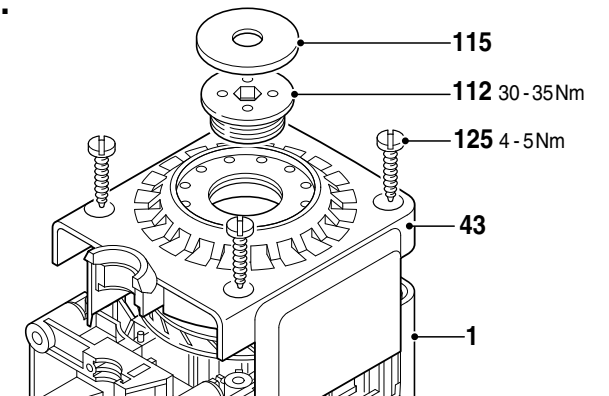

9.

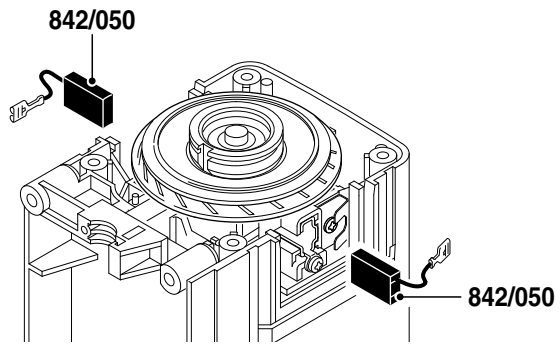

9.1

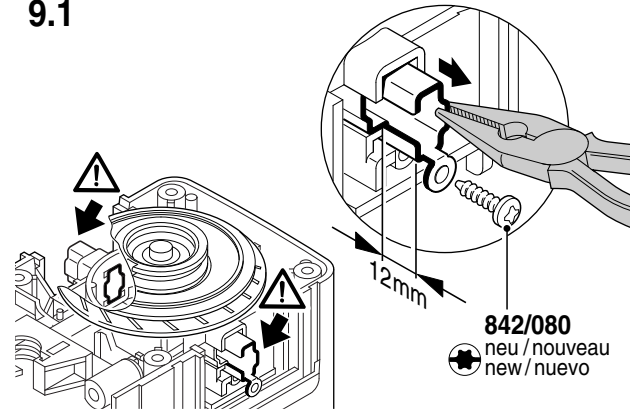

10.

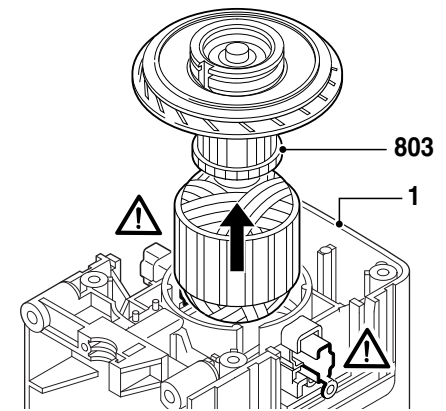

10.1

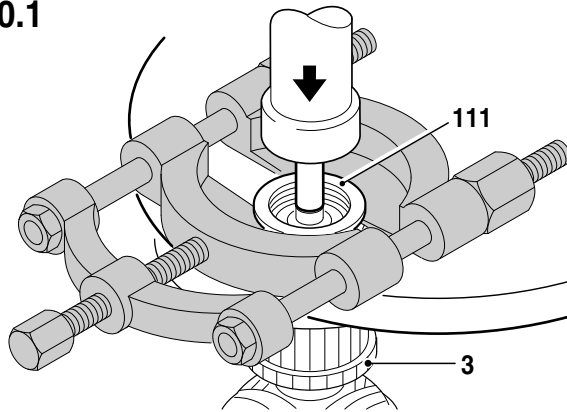

10.2

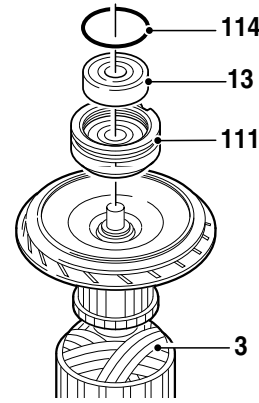

10.3

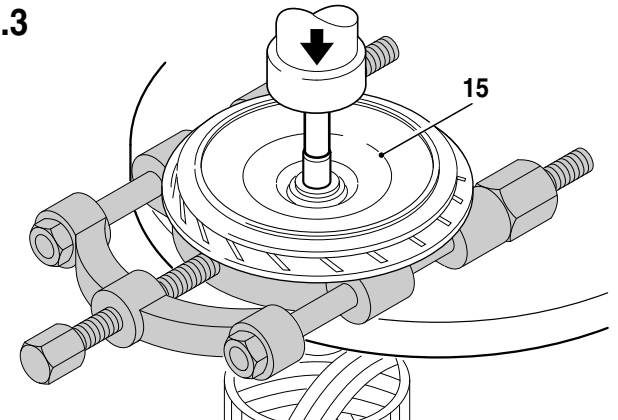

10.4

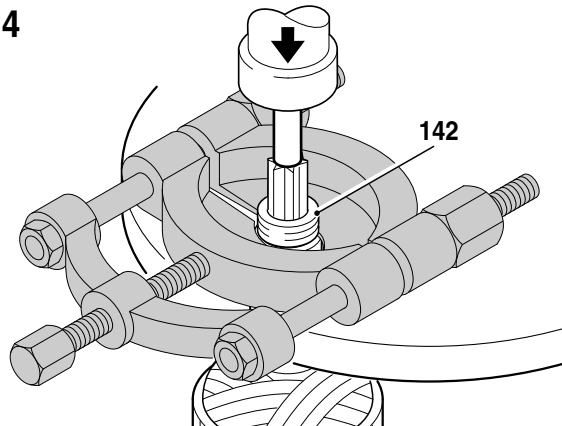

11.

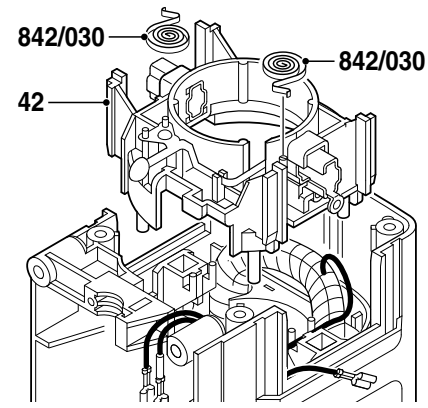

12.

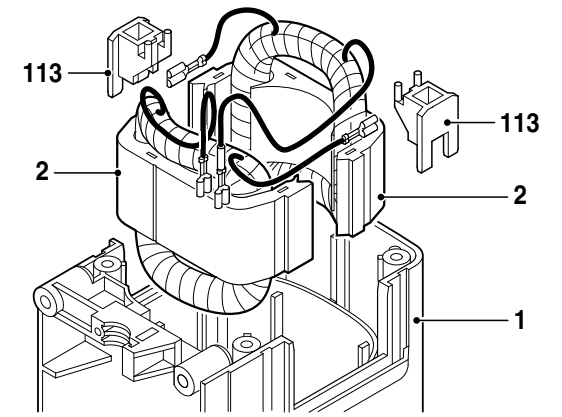

Zusammenbau

Montage nach Explosionszeichnung und diesem Instandsetzungshinweis.

Alle Teile sind gereinigt, abgenutzte und beschädigte Teile werden ersetzt.

Nur Original-Ersatzteile verwenden.

Zähne aller Zahnräder mit Fett **1 615 430 015** bestreichen.

Bitte Schmierhinweise beachten!

Assembly

Assembly using explosion drawings and these repair instructions!

Clean all parts, replace worn-out and damaged parts.

Use only original spare parts!

Grease all gear teeth **1 615 430 015**.

Please note lubrication instructions!

Montage

Le montage s'effectue selon la vue éclatée et les instructions de réparation suivantes.

Toutes les pièces sont nettoyées, les pièces usées ou endommagées doivent être remplacées par des nouvelles. Pour le remplacement de pièces, n'utiliser que des pièces d'origine.

Les dents graisser **1 615 430 015**.

Respecter les instructions de graissage!

Montaje

Realizar el montaje conforme a los dibujos en perspectiva y a estas instrucciones de reparación.

Todas las piezas deben estar limpias. Las piezas desgastadas o dañadas deben reemplazarse por piezas nuevas. Utilizar solamente piezas de repuesto originales.

Dientes engrasar **1 615 430 015**.

Observar las instrucciones de lubricación!

21.

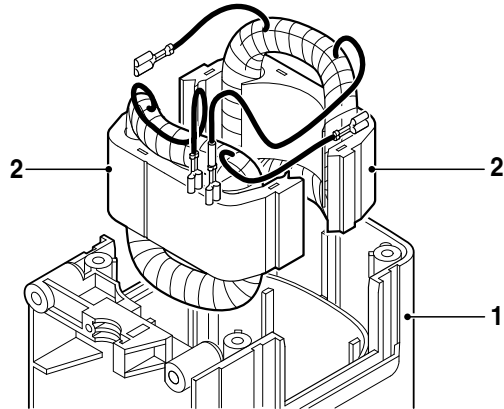

21.1

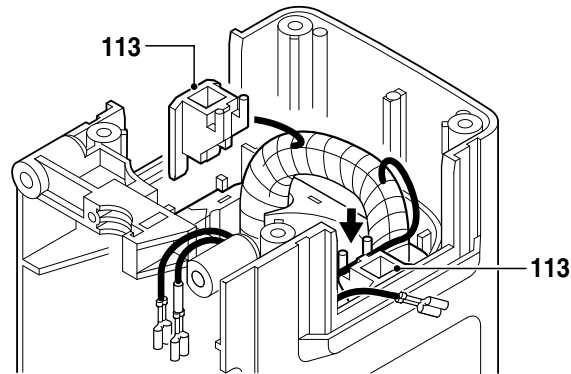

22.

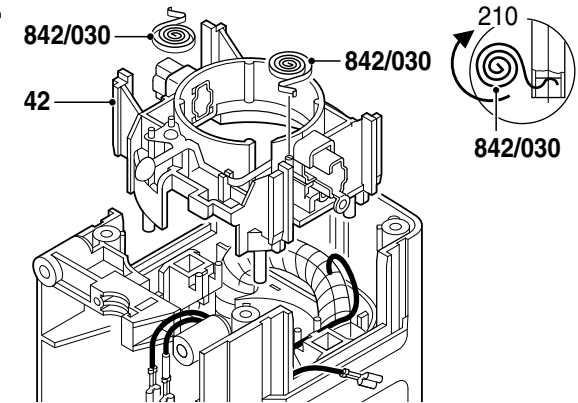

23.

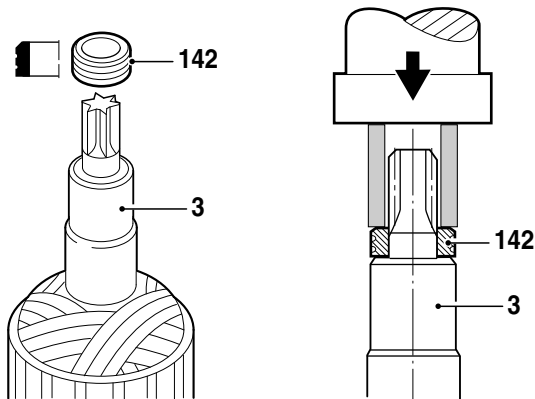

23.1

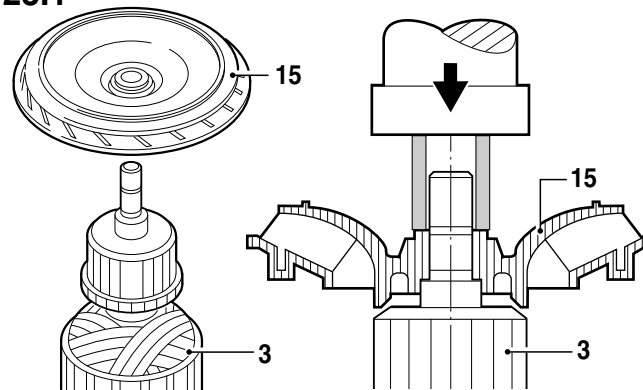

23.2

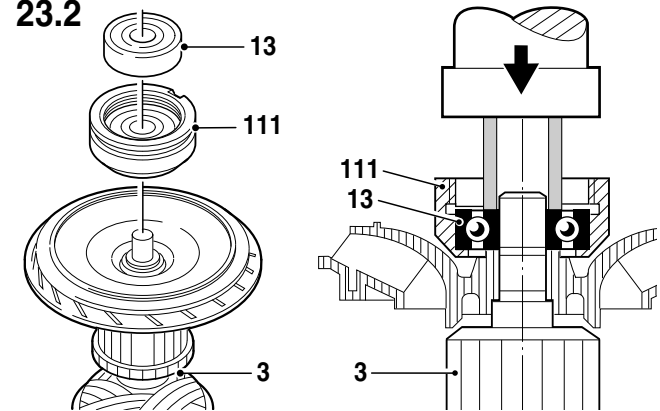

23.3

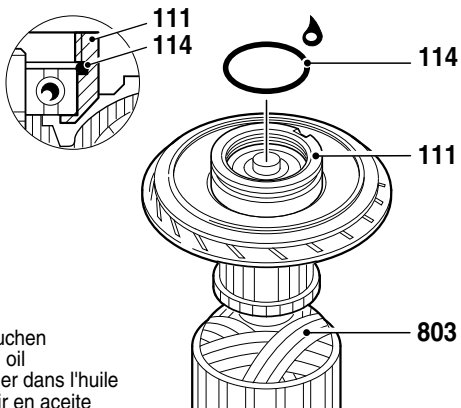

in Öl tauchen
insert in oil
le plonger dans l'huile
sumergir en aceite

23.4

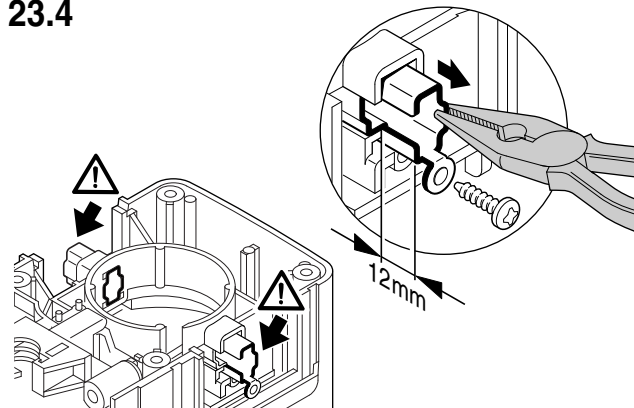

23.5

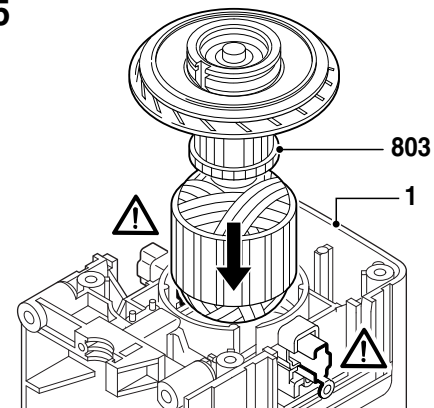

24.

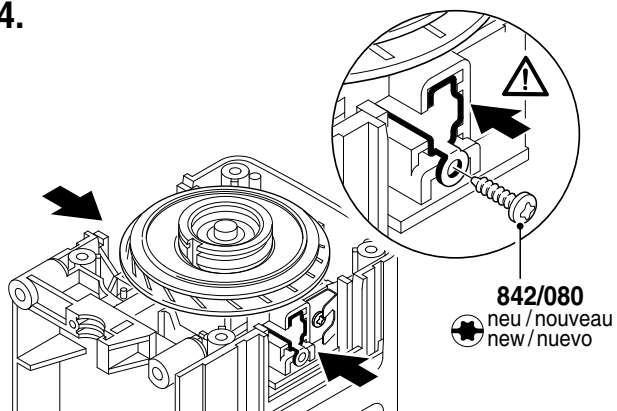

24.1

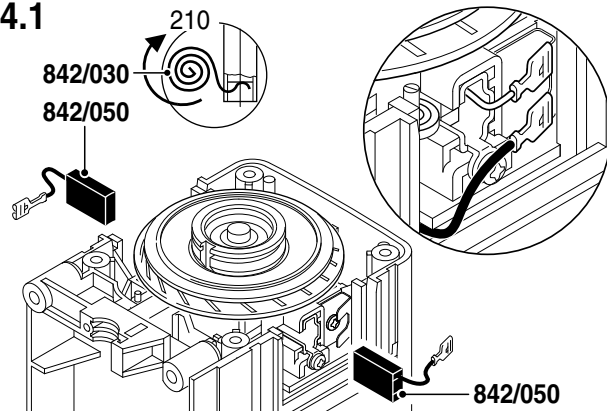

24.2

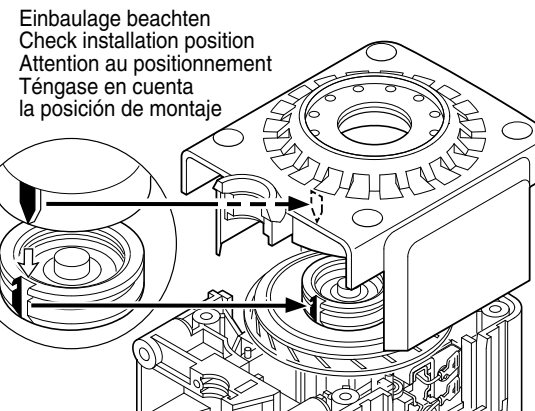

24.3

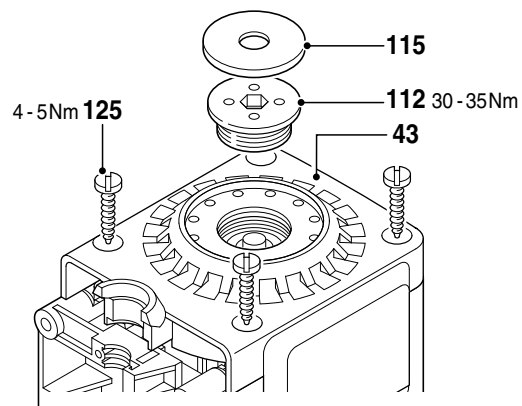

24.4

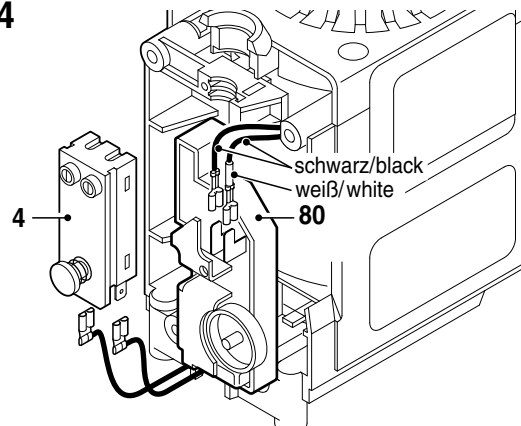

24.5

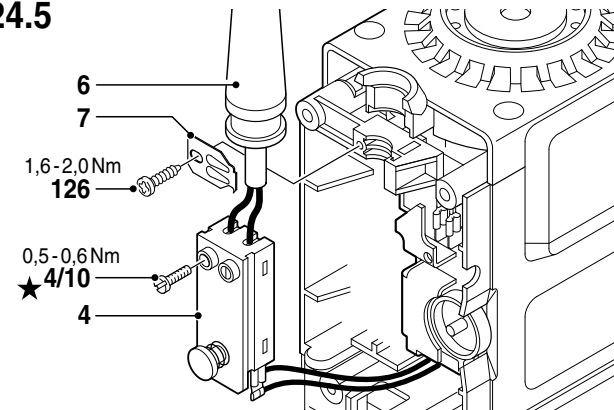

25.

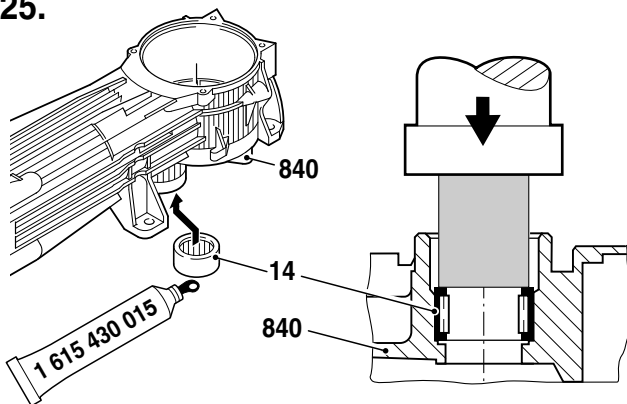

25.1

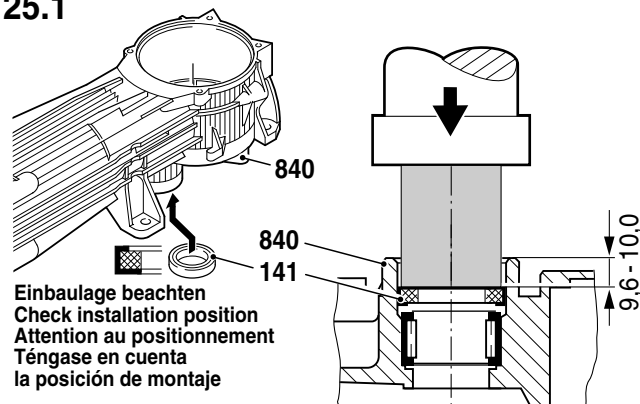

25.2

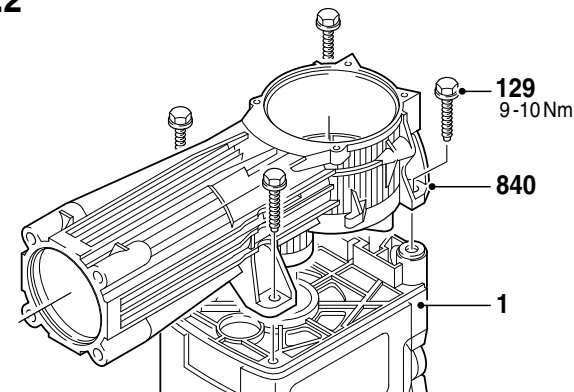

25.3

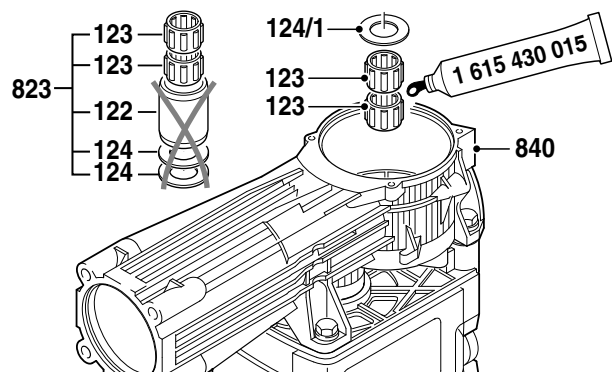

25.4

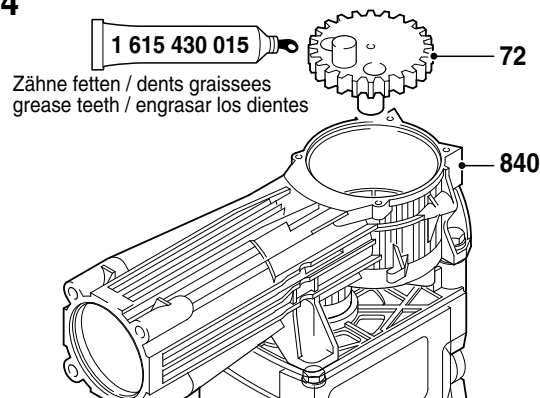

25.5

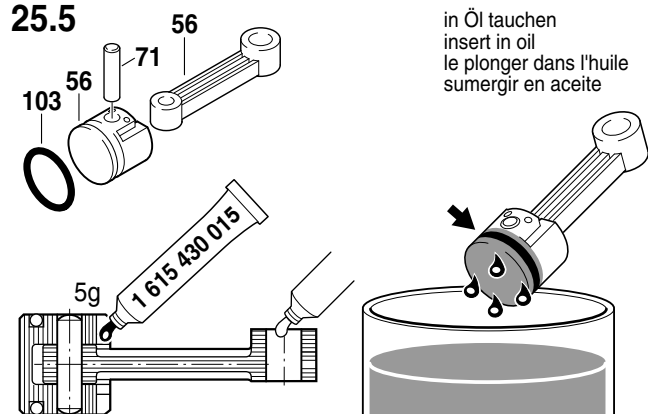

25.6

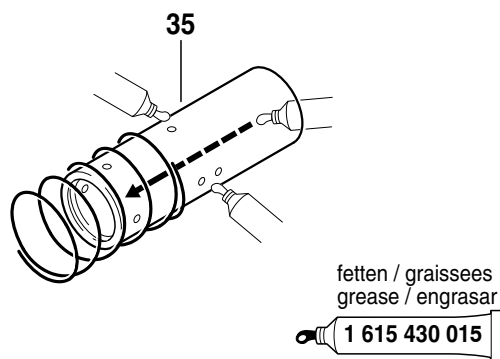

25.7

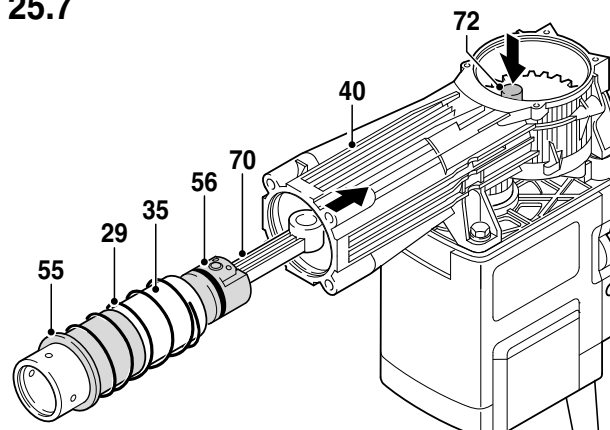

25.8

Pos. 35, 56, 57, 70 fetten (75 - 80g);
 Rest in Getrieberraum Pos. 40.
 Grease the parts pos. 35, 56, 57, 70 (75 - 80g);
 rest into gear compartment pos. 40.
 Graisser les pieces pos. 35, 56, 57, 70 (75 - 80g);
 la graisse restante dans le compartiment d'engrenage pos. 40.
 Engrasar las piezas pos. 35, 57, 70 (75 - 80g);
 resto en el compartimento del engranaje pos. 40.

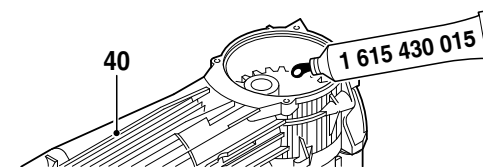

26.

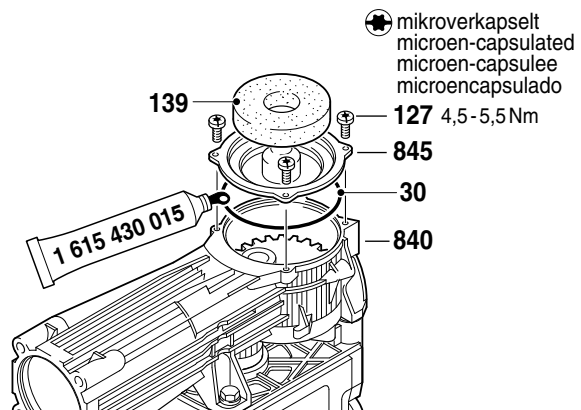

mikroverkapselt
 microen-capsulated
 microencapsulee
 microencapsulado

26.1

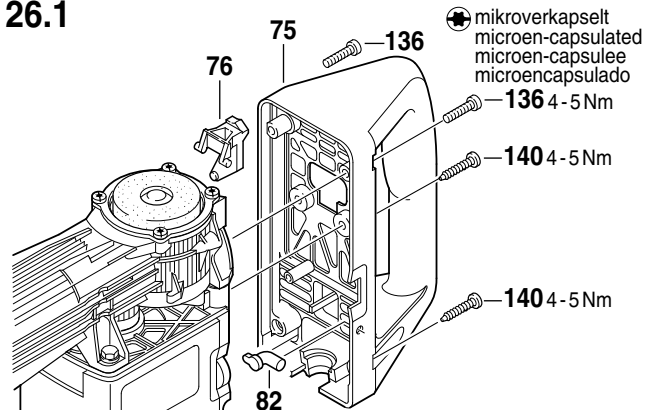

mikroverkapselt
 microen-capsulated
 microencapsulee
 microencapsulado

26.2

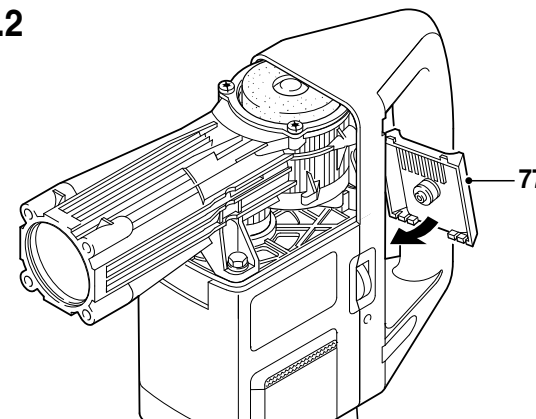

26.3

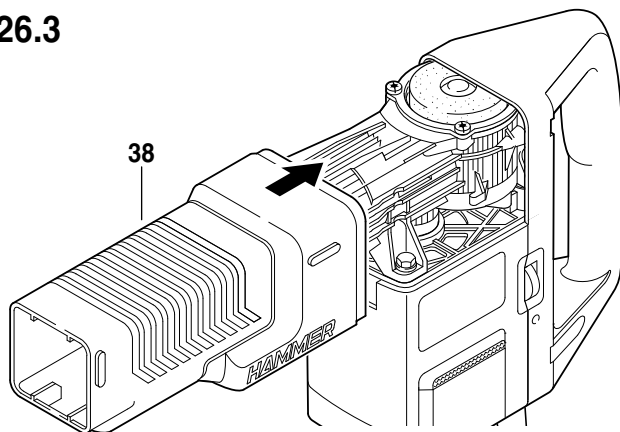

27.

in Öl tauchen
 insert in oil
 le plonger dans l'huile
 sumergir en aceite

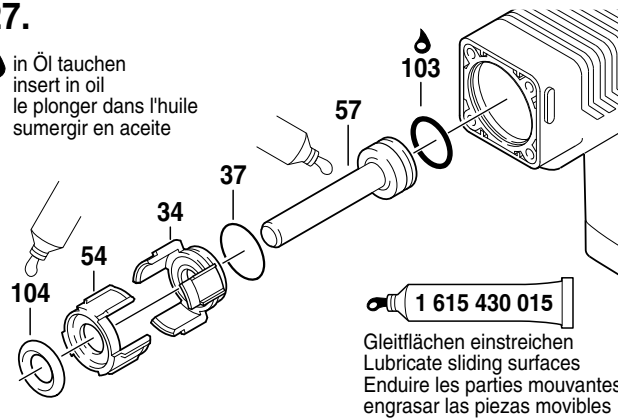

Gleitflächen einstreichen
 Lubricate sliding surfaces
 Enduire les parties mouvant
 engrasar las piezas móviles

27.1

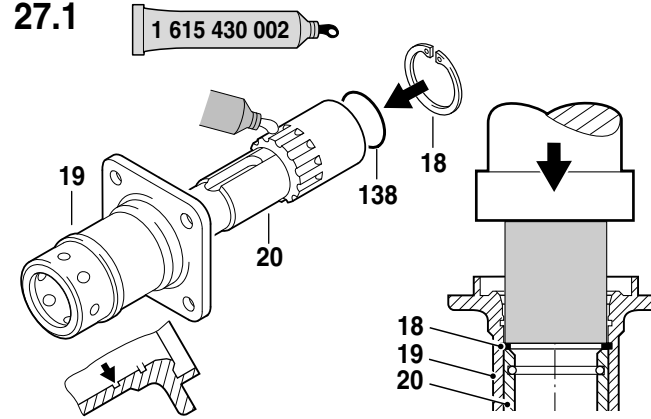

27.2

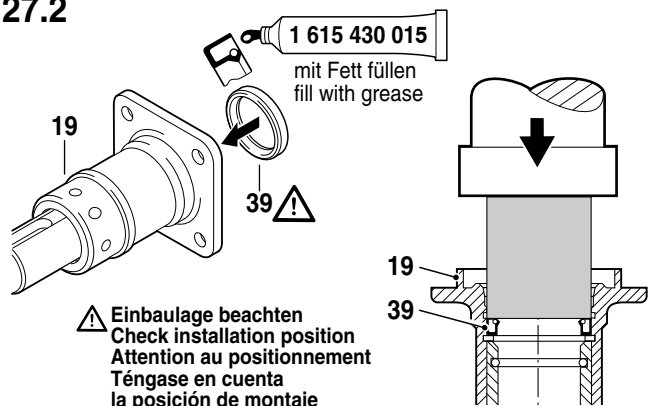

mit Fett füllen
 fill with grease

⚠ Einbauage beachten
 Check installation position
 Attention au positionnement
 Téngase en cuenta
 la posición de montaje

27.3

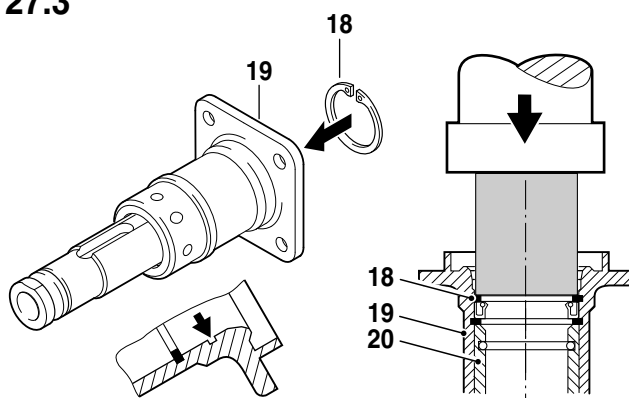

27.4

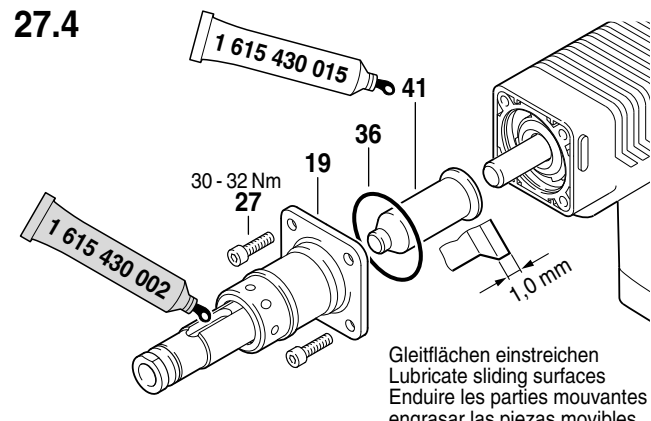

Gleitflächen einstreichen
 Lubricate sliding surfaces
 Enduire les parties mouvant
 engrasar las piezas móviles

28.

Nase fetten / grease nose
graisser nez / engrasar nesar

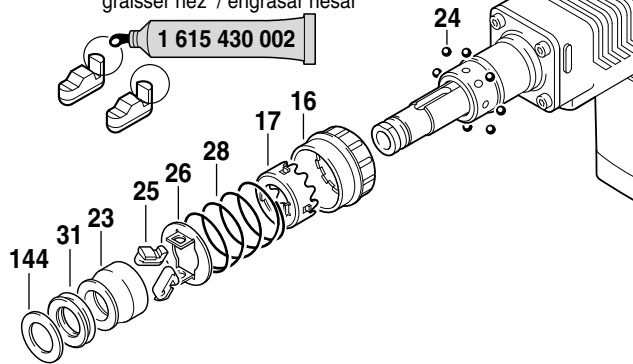

28.1

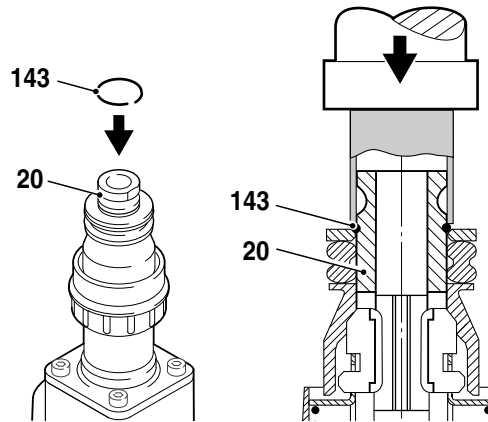

28.2

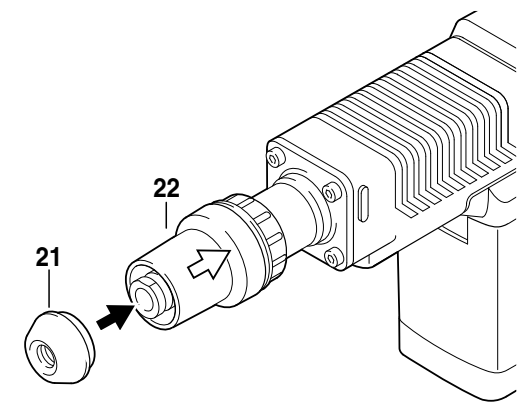

29.

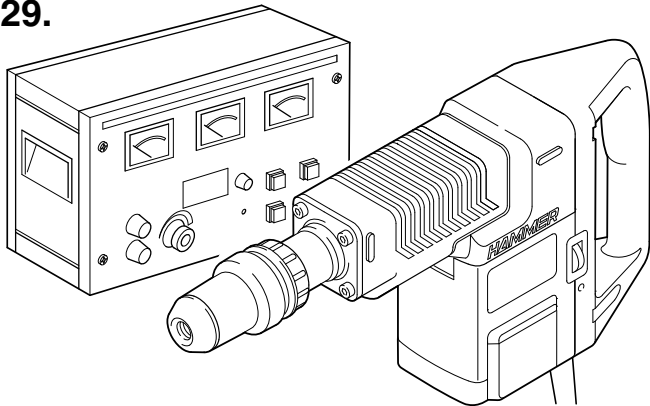

29. Hochspannungsprüfung durchführen.
Beachten:
Die Sicherheitsvorschriften nach DIN, VDE, CEE, AFNOR und weitere in den einzelnen Ländern gültigen Vorschriften sind einzuhalten.
29. Carry out power supply check.
Attention:
Safety regulations according to DIN, VDE, CEE, AFNOR and further regulations applicable in individual countries must be observed.

29. Effectuer un contrôle à haute tension.
Attention:
Respecter les instructions de sécurité selon DIN, VDE, CEE, AFNOR et les autres instructions valables dans les pays respectifs.
29. Efectuar la prueba de alta tensión.
Atención:
Atenerse a las prescripciones de seguridad según DIN, VDE, CEE, AFNOR y a las prescripciones adicionales específicas que pudieran existir en los respectivos países.

30.

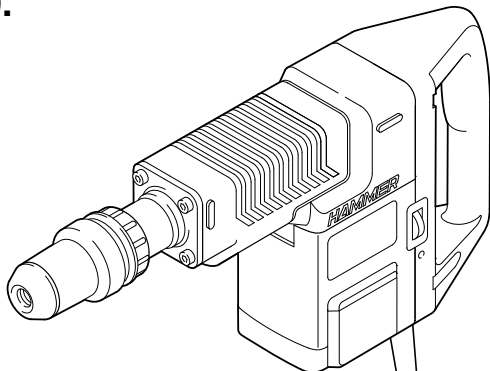

30. Probelauf, Schlagtest, elektrische und mechanische Prüfung durchführen.
30. Perform test run, impact test, electrical and mechanical check-up.

30. Marche à titre d'essai, contrôle de frappe et deperçage, effectuer un contrôle mécanique et électrique.
30. Realizar un control funcional, una prueba de taladrado con y sin percusión y los ensayos eléctricos y mecánicos correspondientes.

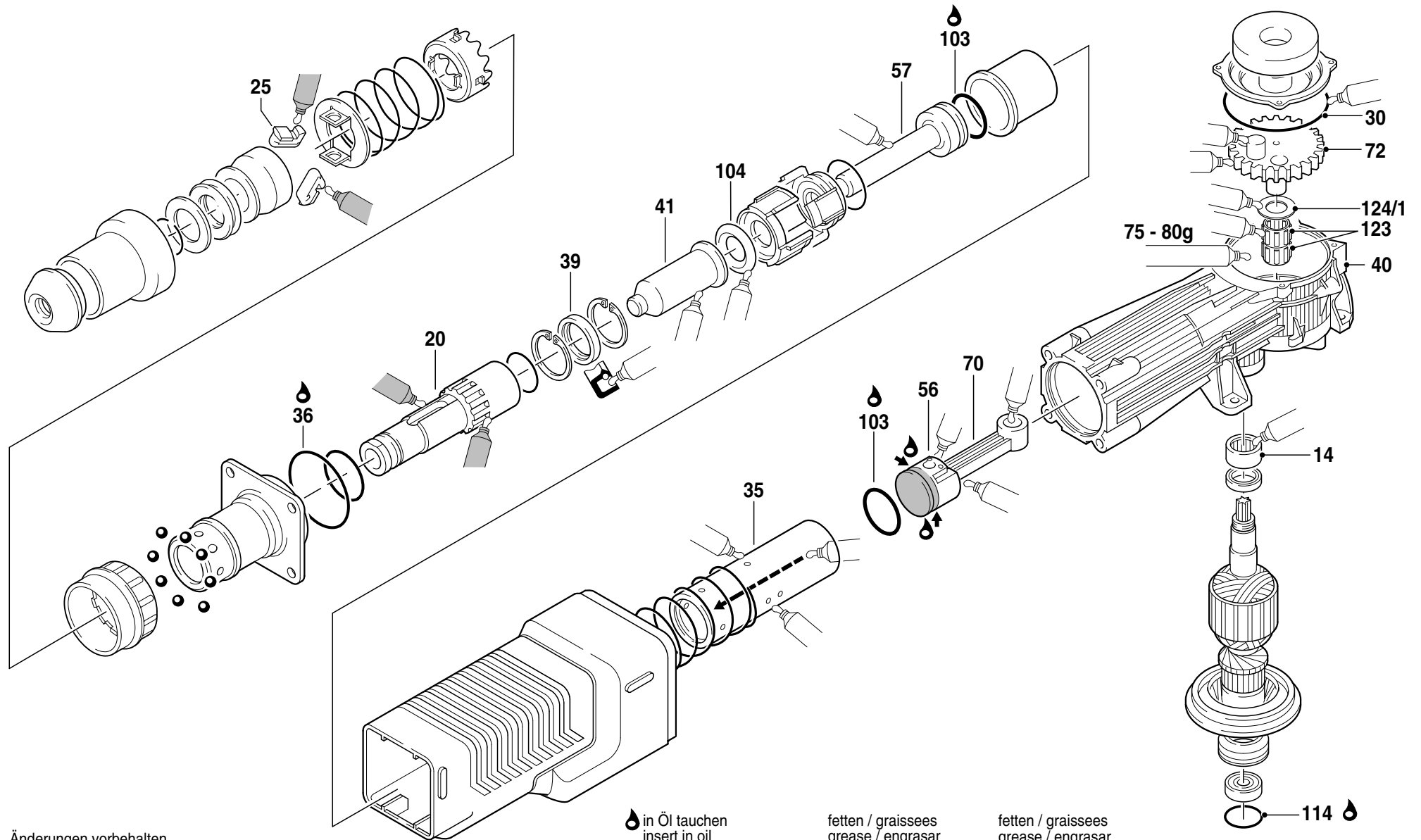

Änderungen vorbehalten
 Modifications reserved
 Modifications réservées
 Salvo modificaciones

in Öl tauchen
 insert in oil
 le plonger dans l'huile
 sumergir en aceite
SAE 20W

fetten / graissées
 grease / engrasar
1 615 430 015

fetten / graissées
 grease / engrasar
1 615 430 002

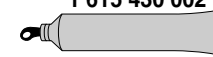
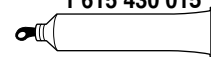

**Schmierung
Lubrication
Lubrification
Lubricacion**

0 611 316 7 . . = GSH 10 E

Stand / Issue: 03-07

Änderungen vorbehalten
Modifications reserved
Modifications réservées
Salvo modificaciones

Schmierstelle Lubrication point Point de lubrification Punto de lubricacion	Fig./Pos.	Schmierstoff Fett Öl Lubricant grease oil Lubrifiant graisse huile Lubricante grasa aceite	Mengen Quantity Quantite Cantidad	Schmiervorschrift Lubricating instructions Indications de graissage Instrucciones de lubricacion
Getriebe und Schlagwerkraum Gear and percussion mechanism space Carter de l' engrenage et boitier du systeme de frappe Engranaje y parte de engranaje	840	1 615 430 015	75-80 g	Teile fetten, Rest in Getrieberaum grease the parts, rest into gear compartment graisser les pieces, la graisse restante dans le compartiment d'engrenage engrasar las piezas, resto en el compartimento del engranaje
O-Ring O-ring Joint torique Antillo toroidal	30 104			fetten grease graisser engrasar
Hammerrohr Hammer pipe Tube de marteau Tubo de martillo	35			fetten grease graisser engrasar
Wellendichtring Shaft sealing ring Joint a levres Reten para arboles	39			Hohlraum zwischen Dichtlippen füllen fill cavity between sealing lips remplir cavite entre les levres du joint llenar el vacio entre los labios del reten
Schlagbolzen Striker pin Percuteur Clavija de percusion	41			fetten grease graisser engrasar
Schläger Striker Frappeur Percutor	57			fetten grease graisser engrasar
Pleuelstange/Exzenterzapfen Connecting rod Bielle Biela	70 72			fetten / Fettdepot füllen, grease / fill cavity graisser / remplir cavite engrasar / llenar el vacio
Exzenterzahnrad Eccentric cog wheel Roue dentee a excentrique Rueda dentada excentrica	72			Zähne füllen, fetten Fill teeth, grease remplir les dentes, graisser Llenar dientes, engrasar

Schmierstelle Lubrication point Point de lubrification Punto de lubricacion	Fig./Pos.	Schmierstoff Fett Öl Lubricant grease oil Lubrifiant graisse huile Lubricante grasa aceite	Mengen Quantity Quantite Cantidad	Schmiervorschrift Lubricating instructions Indications de graissage Instrucciones de lubricacion
Nadellager Needle-roller bearing Roulement a aiguilles Rodamiento de agujas	14 123	1 615 430 015	*	Hohlraum füllen, fetten Fill cavity, grease Remplir cavite, graisser Llenar el vacio, engrasar
Unterlegscheibe Plain washer Rondelle Arandela	124			fetten grease graisser engrasar
Werkzeughalter Tool holder Porte outil Portaherramientas	20	1 615 430 002		fetten grease graisser engrasar
Sperrkörper Stopping device Corps d'arret Cuerpo de bloqueo	25			Nase fetten grease nose graisser neez engrasar nesar
Hammerkolben Hammer piston Piston de marteau Embolo de martillo	56 103	SAE 20 W Mineralöl, handelsüblich Mineral oil, standard / Huile minerale en vente dans le comerc Aceite usual en el comercio		einölen; in Öl tauchen oil; dip in oil huiler le plonger dans l'huile engrasar con aceite; sumergir en aceite
O-Ring O-ring Joint torique Antillo toroidal	36 103 114			einölen; in Öl tauchen oil; dip in oil huiler le plonger dans l'huile engrasar con aceite; sumergir en aceite

*sofern Lager ungefettet
if bearing is unlubricated
si roulement n'est pas graisse
en caso de que el rodamiento
esta son grasa

Prüfwerte

0 611 316 7 . . = GSH 10 E

Stand / Issue: 03-07

Testing values**Valeurs de vérification****Valores de control**

Spannung Voltage Voltage Voltaje	Leerlauf no-load running marche à vide marcha en vacío		Widerstand (20 C/ 68 F) resistance résistance resistencia		Zulässige Übertemperatur im Leerlauf admissible over temperature at no-load élévation admissible de température à vide sobretemperatura admisible en vacío		
V Typ	A	Spindeldrehzahl speed of spindle vitesse de la broche velocidad del husillo 1/min - rpm - t/mn - rpm Stufe	des Ankers of rotor du rotor del rotor W	einer Feldspule of one stator coil d'une bobine du stator de una bobina del estator W	Motor motor moteur motor C	Getriebe gear engrenage engrenaje C	Arbeitsspindel spindle broche husillo C
100	0.000 - 0.000	0 - 0 0 - 0	0.196 - 0.280	0.130 - 0.196	5	6	15
115	0.000 - 0.000	0 - 0 0 - 0	0.265 - 0.367	0.189 - 0.271	5	6	15
120	0.000 - 0.000	0 - 0 0 - 0	0.265 - 0.367	0.189 - 0.271	5	6	15
230	3.643 - 6.658	0 - 0 0 - 0	0.875 - 1.135	0.759 - 0.997	5	6	15
240	0.000 - 0.000	0 - 0 0 - 0	0.875 - 1.135	0.759 - 0.997	5	6	15

Kollektor-Mindestdurchmesser: mm
Minimum diameter of commutator:
Diamètre minimum du collecteur:
Diámetro mínimo del colector:

Kohlebürsten-Mindestlänge:
Minimum length of brushes:
Longueur minimale des balais:
Longitud mínima de las escobillas:

= X Abschaltkohlen
cut-off brushes
charbon rupteur
carbón de desconexión

Änderungen vorbehalten

Unsere Erzeugnisse werden stets dem neuesten technischen Stand angepaßt. Deshalb müssen wir uns Änderungen von technischen Daten vorbehalten.

Modifications

Our products are constantly modified to meet new technical standards. We therefore reserve the right to alter data and specifications without prior notice.

Modifications

Nos produits sont continuellement adaptés aux dernières nouveautés techniques et les dates sont données sous réserve de changement.

Modificaciones

Nuestros fabricados van siendo adaptados constantemente a las últimas conquistas técnicas. Por ello, tenemos que reservarnos el derecho de introducir modificaciones en los datos técnicos.