

Customer CODE 133A

Factory MODEL NO. 309029x11A

REPAIR PARTS CHASSIS & HOOD

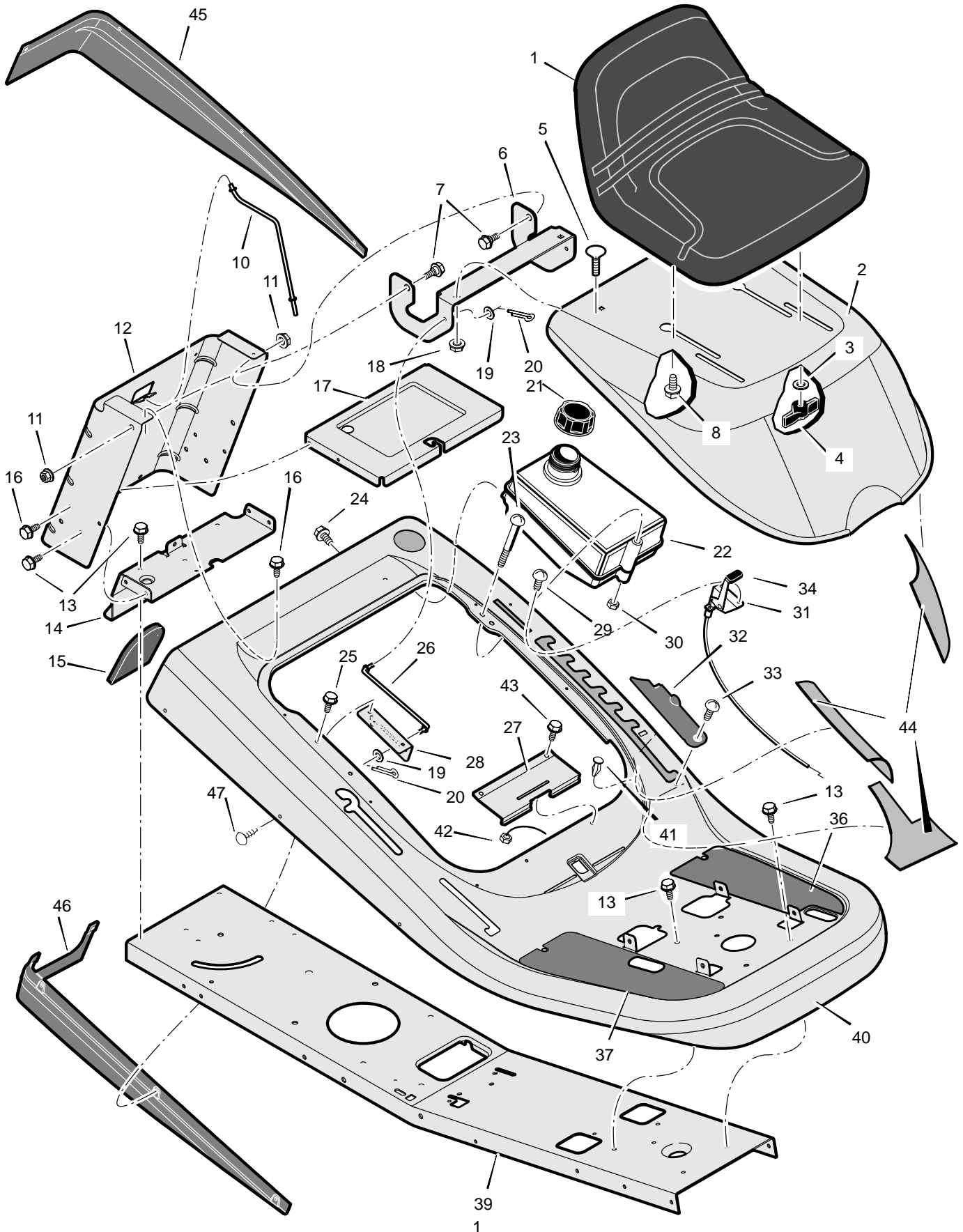

Customer CODE 133A
Factory MODEL NO. 309029x11A

REPAIR PARTS
CHASSIS & HOOD

Key No.	Description	Part No.	Key No.	Description	Part No.
1	Seat	690566	24	Screw	26x253
2	Hood	1401027E549	25	Screw	26x263
3	Washer	017x47	26	Rod, Hood Prop	1401110
4	Bolt, Wing	1001054	27	Spring, Seat Deck	1401041
5	Bolt, Carriage	002x53	28	Bracket, Prop Rod	1401056E701
6	Bracket, Hinge	1401036E701	29	Screw	26x201
7	Bolt, Shoulder	009x29	30	Nut, NY-Lock	15x116
8	Bolt, Shoulder	009x56	31	Control, Throttle	1401248
10	Rod, Battery	1401113	32	Cover, Detent (Black)	1401084
11	Nut, Flange	015x84	33	Bolt, Shoulder	009x47
12	Plate, Rear	1401025E701	36	Footmat, Left (Black)	1401229
13	Screw	26x249	37	Footmat, Right (Black)	1401228
14	Plate, Hitch	1401050E701	39	Frame	1401256E701
15	Cover	1401086	40	Deck, Seat	1401219E549
16	Screw	26x263	41	Bumper	094744
17	Tray, Battery	1401076E701	42	Nut *	15x116
18	Nut, Flange	015x79	43	Screw	0025x2
19	Washer	017x37	44	Kit, Foil Heat Shield	7601036
20	Pin, Cotter	0031x6	45	Trim, Left	1401073
21	Cap, Fuel Tank *	092317	46	Trim, Right	1401072
22	Tank, Fuel	7601040	47	Fastener, Panel	0193x1
23	Screw *	06x111	--	Book, Instruction	F-020601L

* These parts are included when ordering Key number 22.

Customer CODE 133A
Factory MODEL NO. 309029x11A

REPAIR PARTS MOTION DRIVE

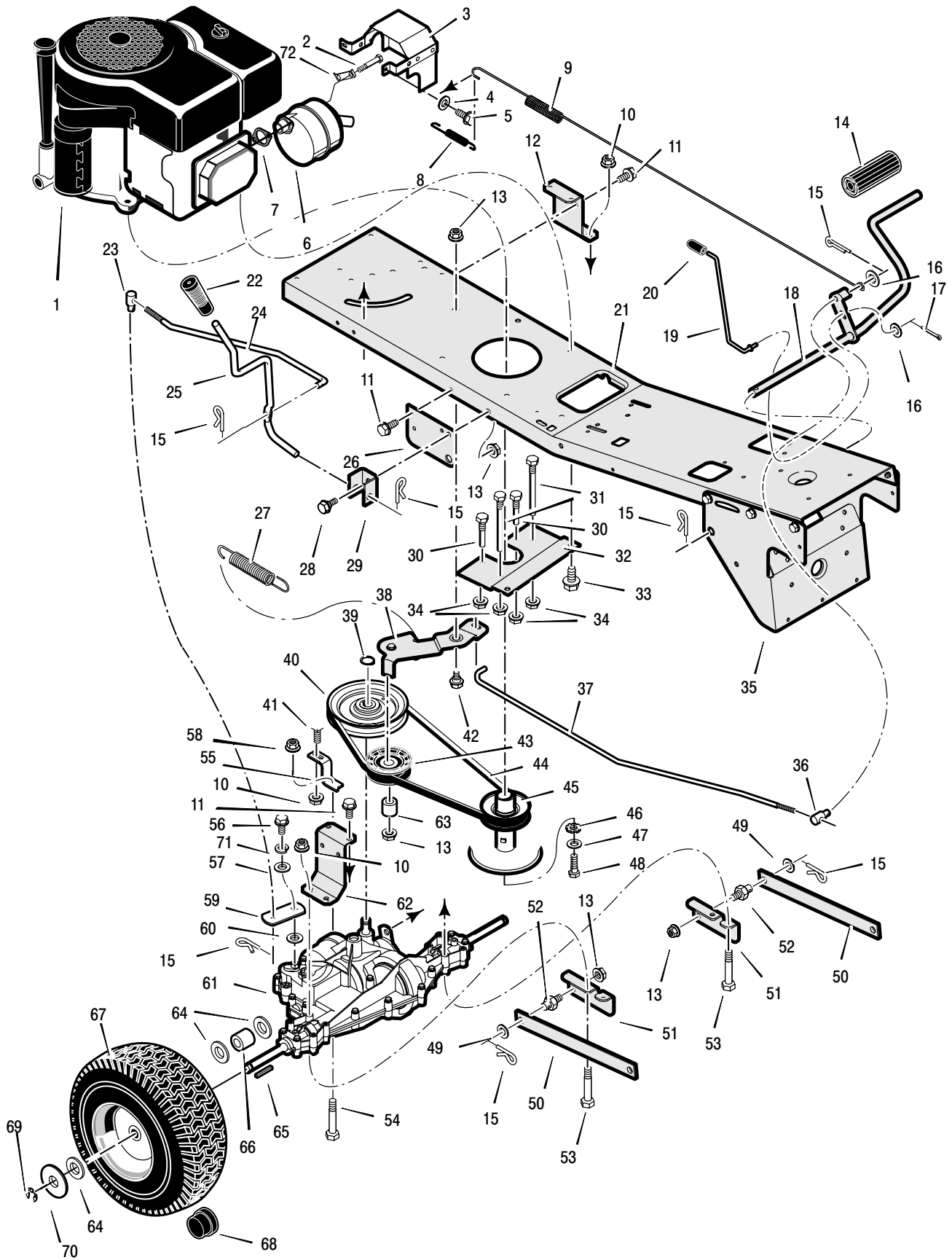

Customer CODE 133A

Factory MODEL NO. 309029x11A

REPAIR PARTS MOTION DRIVE

Key No.	Description	Part No.	Key No.	Description	Part No.
1	Engine, Briggs & Stratton	—	37	Rod, Clutch	1401078
2	Bolt, Hex	01x134	38	Clutch Arm Assembly	1401128
3	Shield Assembly, Heat	1401207	39	Ring, Retainer	0011x7
4	Lockwasher	018x32	40	Pulley, Drive	1401077
5	Screw	0025x2	41	Bolt, Carriage	002x53
6	Muffler	1401251	42	Bolt, Shoulder	009x39
7	Gasket, Muffler	091309	43	Pulley, Idler	690410
8	Spring, Extension	165x75	44	Belt, Motion Drive	37x110
9	Spring, Extension	165x148	45	Pulley, Split Stack	1401066
10	Nut	015x88	46	Washer, Star	019x35
11	Screw	26x249	47	Washer	17x170
12	Bracket, Transaxle –Left	1401042	48	Bolt, Hex	01x140
13	Nut, Flange	015x84	49	Washer	17x102
14	Cover, Pedal	021544	50	Arm, Rear	1401031E701
15	Pin, Cotter	030x20	51	Bracket, Rear Hanger	1401039
16	Washer	017x53	52	Pin, Threaded Shoulder	094067
17	Pin, Cotter	030x20	53	Bolt, Hex	01x155
18	Pedal Assembly	1401127E701	54	Bolt	01x120
19	Rod, Parking Brake	1401112	55	Bracket, Torque Reactor	1401051E701
20	Grip, Parking Brake Rod	091079	56	Screw	01x145
21	Frame	1401256E701	57	Washer, Shift Yoke	710657
22	Grip, Shift Lever	092697	58	Nut	015x43
23	Nut, Adjusting	1401148	59	Yoke, Shift	1401093
24	Link, Shift	1401122	60	Washer	17x148
25	Lever, Shift	1401111	61	Transaxle, Peerless	—
26	Bracket, Lift Pivot	1401032	62	Bracket, Transaxle	1401042
27	Spring, Extension	165x147	63	Spacer	690369
28	Bolt, Shoulder	009x39	64	Washer	17x160
29	Bracket, Pivot	1401043	65	Key, Square	056534
30	Guide, Belt –Short	1401104	66	Spacer, Rear Wheel	1401103
31	Guide, Belt –Long	1401105	67	Wheel, Rear –15”	1401120
32	Plate, Belt Guide	1401057	68	Cap, Hub	094618
33	Bolt	0025x7	69	E–Ring	011x3
34	Nut, Flange	015x79	70	Washer	17x195
35	Bracket, Support	1401059	71	Lockwasher, Split	018x32
36	Nut, Adjusting	094815	72	Lock, Screw	092378

* When you order a tire, make sure to give the brand name of the tire so that the tread pattern on the tire will match.

** For information on Replacement Parts see the Central Parts Distributor in your area.

Customer CODE 133A
Factory MODEL NO. 309029x11A

REPAIR PARTS

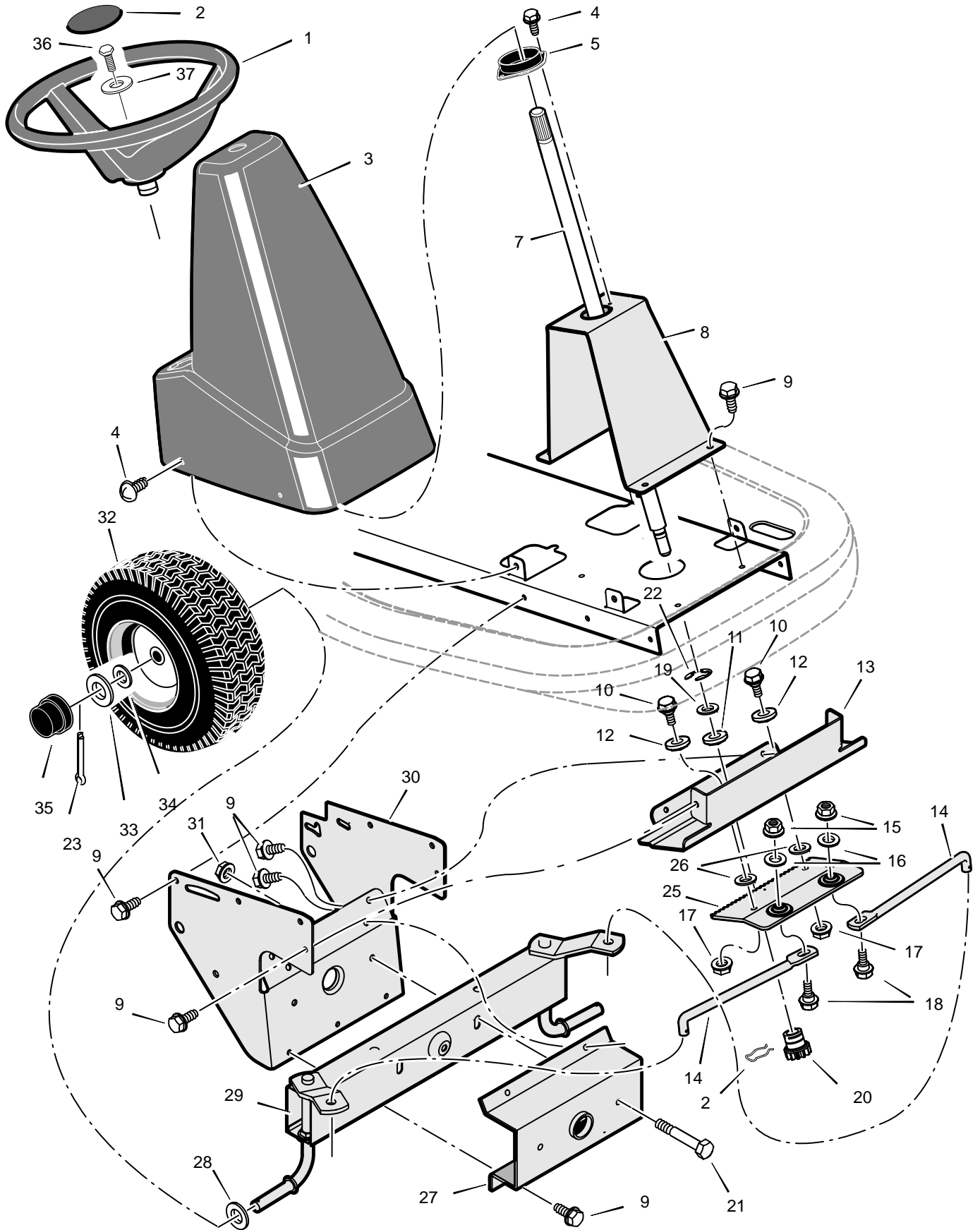

Customer CODE 133A
Factory MODEL NO. 309029x11A

REPAIR PARTS
STEERING

Key No.	Description	Part No.	Key No.	Description	Part No.
1	Wheel, Steering	095185	20	Gear, Pinion	1401099
2	Cap, Steering	711326	21	Bolt, Hex	01x146
3	Console, High –Black	1401067	22	E–Ring, Retainer	011x28
4	Screw	26x270	23	Pin, Cotter	030x35
5	Bearing, Upper Steering	1401090	25	Rack, Steering	1401046E701
7	Shaft, Steering	1401100	26	Washer	17x102
8	Support, Steering	1401055E701	27	Bracket, Axle Front	1401060E701
9	Screw	26x249	28	Washer	17x157
10	Bolt, Shoulder	009x67	29	Axle & Spindle Assembly	1401126E701
11	Bearing, Lower Steering	1401098	30	Bracket, Support	1401059E701
12	Roller	1401102	31	Nut, Flange	15x118
13	Plate, Gear Mounting	1401058E701	32	Wheel, Front	1401143
14	Link, Drag	1401123E701	33	Washer	17x197
15	Nut, Flange	015x84	34	Washer	17x157
16	Washer	17x104	35	Cap, Hub	094618
17	Nut, Flange	015x88	36	Bolt	0025x3
18	Bolt, Hex	01x111	37	Washer	17x146
19	Washer	17x118			

* When you order a tire, make sure to give the brand name of the tire so that the tread pattern on the tire will match.

Customer CODE 133A

Factory MODEL NO. 309029x11A

REPAIR PARTS MOWER HOUSING SUSPENSION

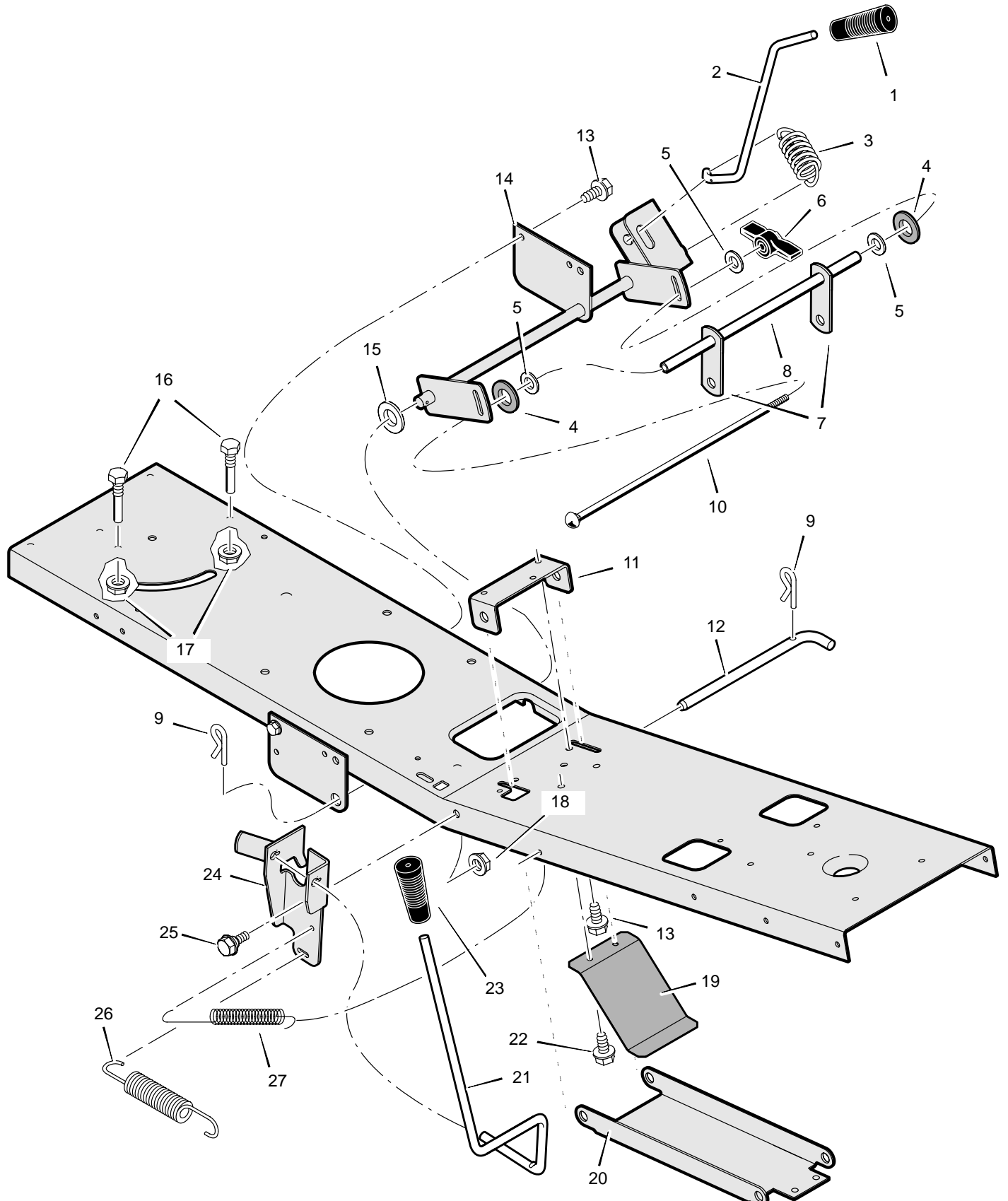

Customer CODE 133A

Factory MODEL NO. 309029x11A

**REPAIR PARTS
MOWER HOUSING SUSPENSION**

Key No.	Description	Part No.	Key No.	Description	Part No.
1	Grip, Lift Lever	092697	15	Washer	17x165
2	Lever, Lift	1401117	16	Screw, Guide	093349
3	Spring, Extension	165x154	17	Nut, Flange	015x79
4	Pad, Friction	094137	18	Nut, Flange	015x84
5	Washer	017x45	19	Spring, Leaf	1401147
6	Wingnut	095004	20	Hanger, Front	1401040E701
7	Link, Lift	1401033E701	21	Lever, PTO	1401116
8	Tube, Spacer	1401096	22	Screw	26x263
9	Pin, Hair	0031x4	23	Grip, PTO	094198
10	Bolt, Carriage	002x93	24	Bracket, PTO	1401199E701
11	Bracket, Front Hanger Pivot	1401030E701	25	Bolt, Shoulder	009x42
12	Pin, Front Hanger	1401118	26	Spring, Extension	165x157
13	Screw	26x249	27	Spring, Extension	165x92
14	Arm Assembly, Lifter	1401129E701			

Customer CODE 133A
Factory MODEL NO. 309029x11A

REPAIR PARTS
MOWER HOUSING

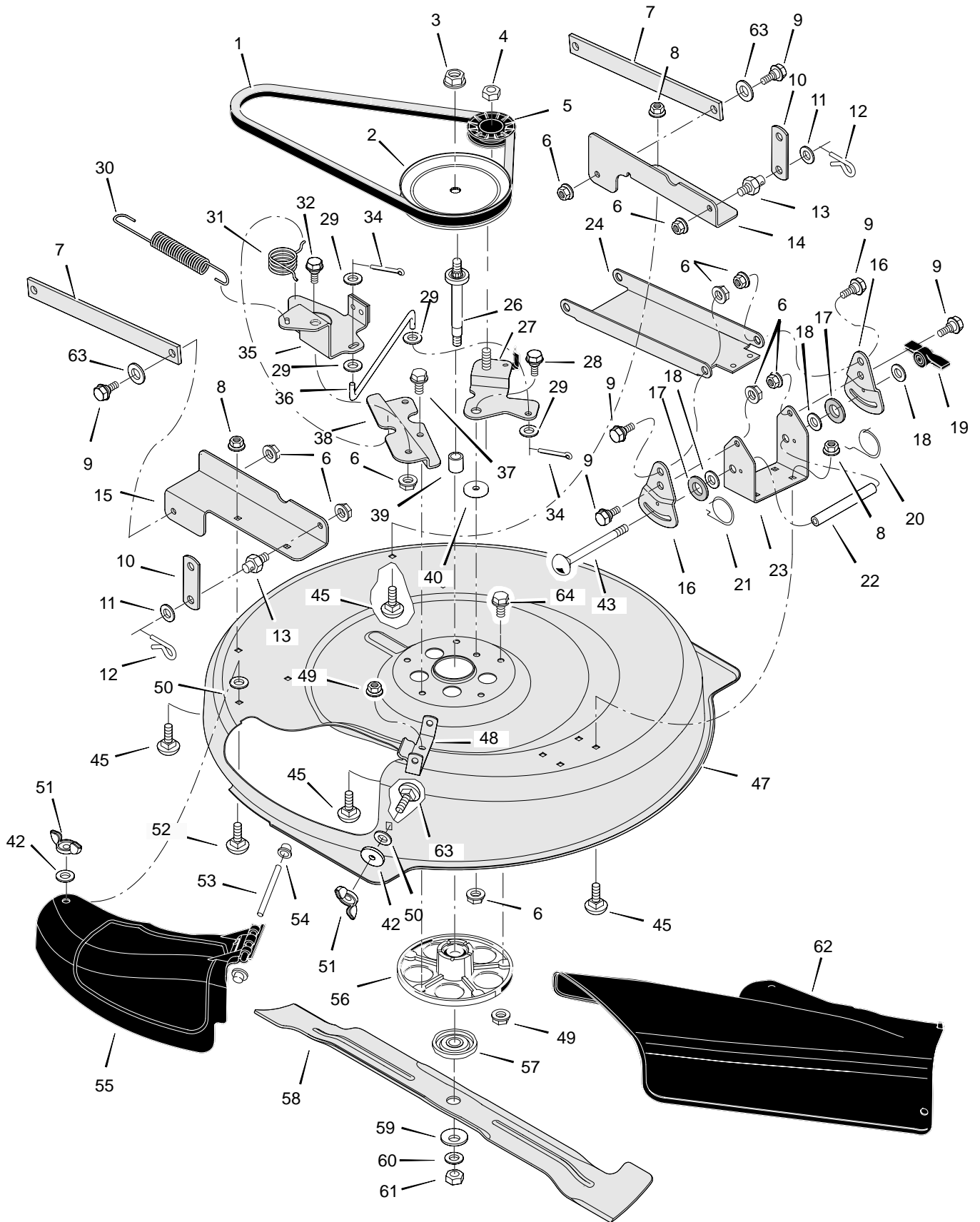

Customer CODE 133A
Factory MODEL NO. 309029x11A

REPAIR PARTS
MOWER HOUSING

Key No.	Description	Part No.	Key No.	Description	Part No.
1	37x111	Belt, Blade Drive	32	009x42	Bolt, Shoulder
2	1401092	Pulley, Input	34	030x20	Pin, Cotter
3	15x121	Locknut	35	1401185E701	Arm Assembly, Brake
4	015x98	Nut, Flange	36	1401119	Link, Idler Arm
5	1401252	Pulley, Idler	37	0025x7	Bolt
6	015x84	Nut, Flange	38	1401052E701	Bracket, Brake Mounting
7	1401031E701	Arm, Rear	39	1401094	Spacer, Jackshaft
8	015x79	Nut, Flange	40	1401097	Washer
9	009x58	Bolt, Shoulder	42	019x45	Washer
10	1401033E701	Link, Lift	43	002x94	Bolt, Carriage
11	17x102	Washer	45	002x53	Bolt, Carriage
12	0031x4	Pin, Hair	47	1401028E701	Housing, Blade
13	094067	Pin, Threaded Shoulder	48	1401106E701	Hinge, Mulching Cover
14	1401047E701	Bracket, Left Rear	49	015x88	Nut, Flange
15	1401235E701	Bracket, Right Rear	50	028x76	Nut, Speed
16	1401038E701	Plate, Adjustment	51	014x86	Wingnut
17	094137	Pad, Friction	52	002x74	Bolt, Carriage
18	017x45	Washer	53	091767 Z	Rod, Chute Deflector
19	095004	Wingnut	54	028x23	Cap, Push
20	166x43	Spring, Left Torsion	55	1401080	Cover, Mulch
21	166x42	Spring, Right Torsion	56	094305	Mandrel Housing
22	1401095	Tube, Spacer	57	1001035	Adapter, Blade
23	1401037E701	Bracket, Deck	58	1401079E701	Blade
24	1401040E701	Hanger, Front	59	17x166	Washer, Cup
26	1401065	Shaft, Splined	60	17x165	Washer
27	1401258E701	Arm, Idler	61	15x100	Nut, Blade Mount
28	009x39	Bolt, Shoulder	62	1401081	Deflector, Chute
29	017x47	Washer	63	002x74	Bolt, Carriage
30	165x157	Spring, Extension	64	001x84	Bolt
31	166x46	Spring, Torsion			

Customer CODE 133A
Factory MODEL NO. 309029x11A

REPAIR PARTS
ELECTRICAL SYSTEM

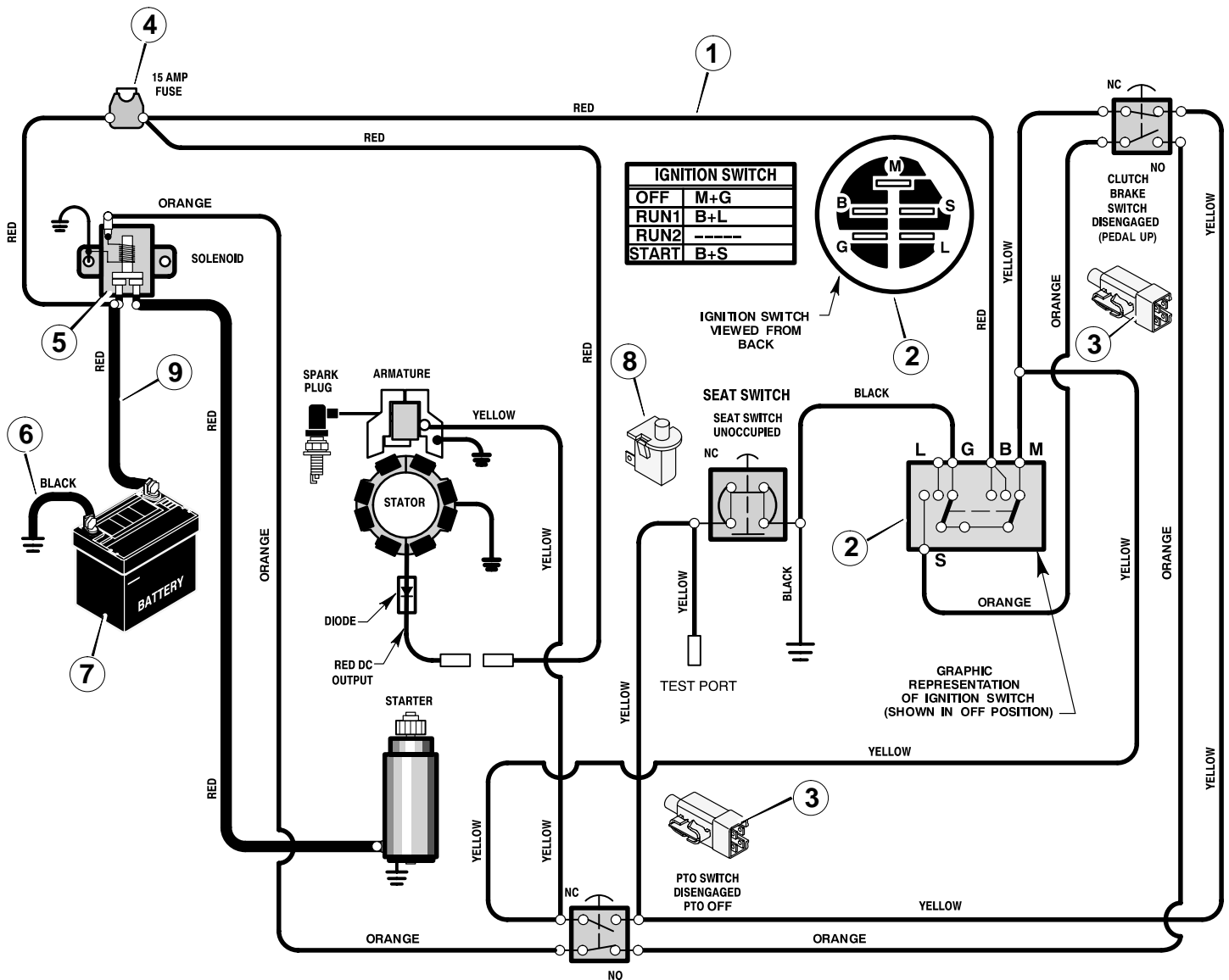

Customer CODE 133A
Factory MODEL NO. 309029x11A

REPAIR PARTS
ELECTRICAL SYSTEM

Key No.	Description	Part No.
1	Harness, Chassis Wire	250x103
2	Switch, Ignition	1401149
	Key, Ignition	327349
3	Switch, Limit	094136
4	Fuse	054212
	Holder, Fuse	407078
5	Solenoid	094613
	Screw, Mounting	26x229
	Locknut	15x116
6	Cable, Battery Ground	024x37
7	Battery	092739
	Bolt, Carriage	002x82
	Wingnut	014x79
8	Switch, Seat Sensor	094159
9	Cable, Red Batery	024x24
	Boot, Positive Terminal	690604

Customer CODE 133A

Factory MODEL NO. 309029x11A

**REPAIR PARTS
DECALS**

Ke No.	Description (Location)	Part No.	Qty.
--	DEKA	44x7197	1
--	10 HP B & S	44x7388	2
--	HERITAGE 10/30	48X1052	1
--	HERITAGE 10/30	48X1053	1
--	Cut Finger	44x5430	1
--	Caution/Warning	48x725	1
--	1-6 Heigt Adjust – Lift Lever	48x727	1
--	Deck Leveling	44x6456	1
--	No Step	44x5429	1
--	Brake / Clutch	48x736	1
--	Hayter	48x1054	1
--	Gear Select 5 Speed	48x723	1
--	Heat Shield Warning	44x5936	1
--	Drawbar Warning	48x511	1
--	Warning –Pinch Point	44x6828	1
--	TUV & GS European Xport	44x2929	1
--	Hayters Serial No.	48x1055	1
--	Hytters CTN Label	48x1056	1
--	Engagement Lever	48x724	1
--	Park Brake Symbol	48x726	1
--	Throttle Control	48x728	1
--	Gas Gauge	48x729	1