

VISTE ESPLOSE
EXPLODED VIEWS

VUES ECLATEES
SPRENGZEICHNUNGEN

R 430
R 430 S
R 480

Mod. 1998

CHASSIS - MANICO - COMANDI - DOTAZIONE VITERIE
DECK - HANDLE - CONTROLS - SCREWS OUTFITS
CHÂSSIS - MANCHERON - COMMANDES - DOTATION VISSERIE
GEHÄUSE - HOLM - BETÄTIGUNGEN - SCHRAUBENSATZ

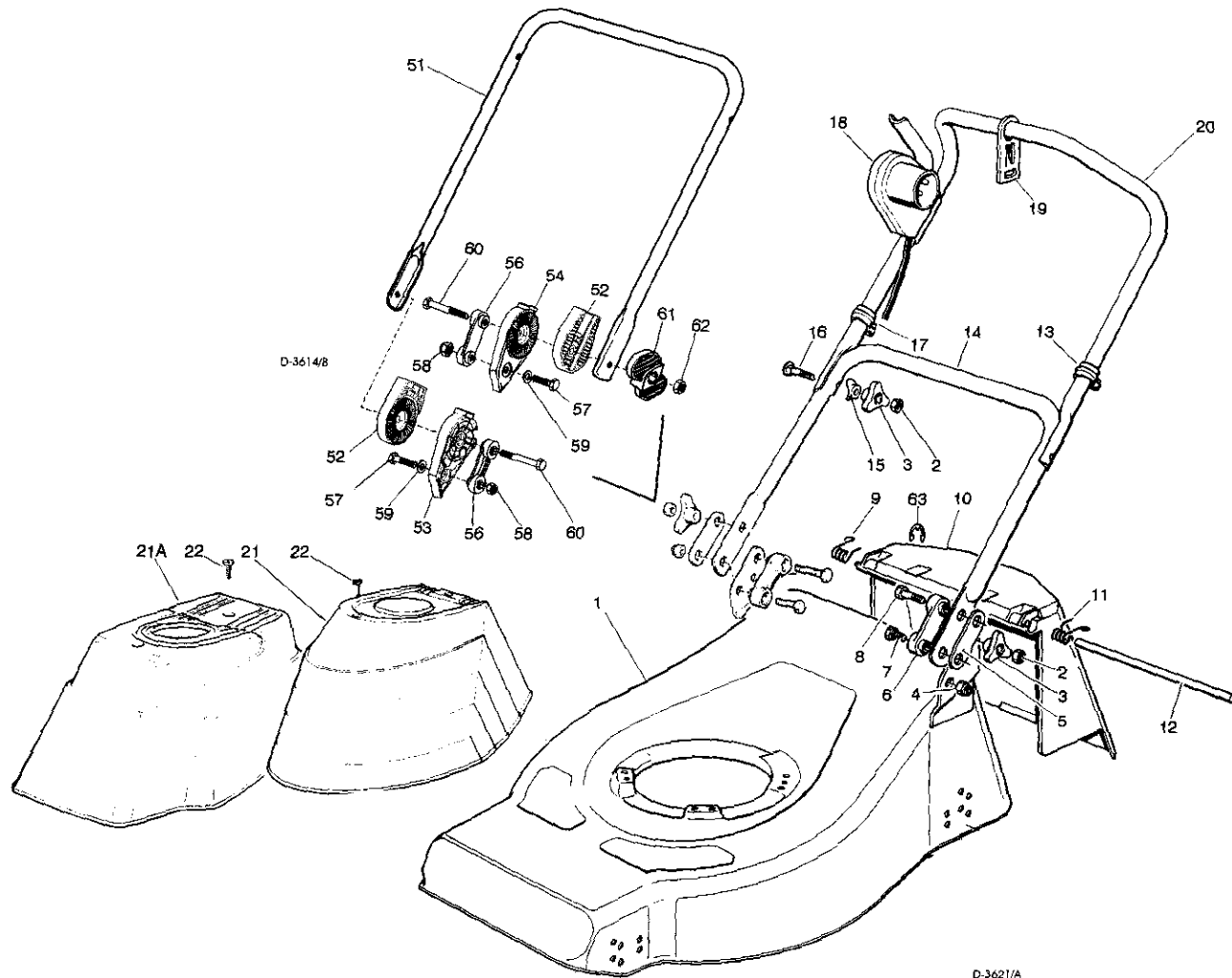

T-3621/A

Pos. Nr.	Codice Kodex Code	Descrizione	Description	Description	Beschreibung	Q.tà Q.ty Q.té Menge
1	81000950/1	CHASSIS ROSSO R 430	RED DECK R 430	CHÂSSIS ROUGE R 430	ROTES GEHÄUSE R 430	1
—	81000988/1	CHASSIS GIALLO R 430	YELLOW DECK R 430	CHÂSSIS JAUNE R 430	GELBES GEHÄUSE R 430	1
—	81001542/1	CHASSIS VERDE R 430	GREEN DECK R 430	CHÂSSIS VERT R 430	GRÜNES GEHÄUSE R 430	1
—	81000952/0	CHASSIS ROSSO R 480	RED DECK R 480	CHÂSSIS ROUGE R 480	ROTES GEHÄUSE R 480	1
—	81000991/0	CHASSIS GIALLO R 480	YELLOW DECK R 480	CHÂSSIS JAUNE R 480	GELBES GEHÄUSE R 480	1
—	81001543/0	CHASSIS VERDE R 480	GREEN DECK R 480	CHÂSSIS VERT R 480	GRÜNES GEHÄUSE R 480	1
2	12293200/0	DADO	NUT	ECROU	MUTTER	4
3	22399900/0	MANOPOLINA	KNOB	POIGNÉE	GRIF	4
4	12155000/0	DADO	NUT	ECROU	MUTTER	2
5	22551574/0	PIASTRINA ESTERNA	OUTSIDE PLAQUE	PLAQUETTE EXTERNE	ISOLIERPLATTE	2
6	22551575/0	PIASTRINA INTERNA	INSIDE PLAQUE	PLAQUETTE INTERNE	ISOLIERPLATTE	2
7	12793300/0	VITE	SCREW	VIS	SCHRAUBE	2
8	12691115/0	VITE	SCREW	VIS	SCHRAUBE	2
9	22450410/1	MOLLA DX	RIGHT SPRING	RESSORT DROITE	RECHTE FEDER	1
10	22600028/4	PARASSASSI	STONE-GUARD	PARE-PIERRES	PRALLBLECH	1
11	22450420/1	MOLLA SX	LEFT SPRING	RESSORT GAUCHE	LINKE FEDER	1
12	22517906/1	PERNO	PIN	PIVOT	BOLZEN	1
13	22192151/0	FERMACAVO	FAIR LEAD	FIXATION CABLE	KABELBEFESTIGUNG	1
14	81006512/0	PARTE INF. MANICO	LOWER HANDLE	PARTIE INF. MANCHERON	UNTERHOLM	1
15	226800061/1	RONDELLA	WASHER	RONDELLE	SCHIBE	2
16	12819201/0	VITE	SCREW	VIS	SCHRAUBE	2
17	22192000/1	FASCETTA ANCORAGGIO	ANCHOR CLAMP	COLLIER ANCRAGE	BOWDENZUGHALTER	2

Pos. Nr.	Codice Kodex Code	Descrizione	Description	Description	Beschreibung	Q.tà Q.ty Q.té Menge
18	18710562/0	SALVAMOTORE M.M. 8,5 A 602 MS (1300W IBMEI/RST)	DEAD HAND SWITCH M.M. 8,5 A 602 MS (1300W IBMEI/RST)	INT. MAIN MORTE M.M. 8,5 A 602 MS (1300W IBMEI/RST)	TOT MANSCHALTER M.M. 8,5 A 602 MS (1300W IBMEI/RST)	1
—	18710563/0	8,5 A 603 MS (1300W IBMEI/RST) SOLO PER SVIZZERA	8,5 A 603 MS (1300W IBMEI/RST) ONLY FOR SWITZERLAND	8,5 A 607 MS (1300W IBMEI/RST) SEULEMENT POUR LA SUISSE	8,5 A 607 MS (1300W IBMEI/RST) NUR FÜR SCHWEIZ	1
—	18710624/1	8,5 A 607 MS (1300W IBMEI)	8,5 A 607 MS (1300W IBMEI)	8,5 A 607 MS (1300W IBMEI)	8,5 A 607 MS (1300W IBMEI)	1
—	18710604/0	10 A 602 MS (1600W IBMEI/RST)	10 A 602 MS (1600W IBMEI/RST)	10 A 602 MS (1600W IBMEI/RST)	10 A 602 MS (1600W IBMEI/RST)	1
—	18710572/0	10 A 603 MS (1600W IBMEI/RST) SOLO PER SVIZZERA	10 A 603 MS (1600W IBMEI/RST) ONLY FOR SWITZERLAND	10 A 603 MS (1600W IBMEI/RST) SEULEMENT POUR LA SUISSE	10 A 603 MS (1600W IBMEI/RST) NUR FÜR SCHWEIZ	1
—	18710628/0	10 A 607 MS (1600W IBMEI)	10 A 607 MS (1600W IBMEI)	10 A 607 MS (1600W IBMEI)	10 A 607 MS (1600W IBMEI)	1
19	22195101/0	FERMACAVO	FAIR LEAD	FIXATION CABLE	KABELBEFESTIGUNG	1
20	81007017/1	PARTE SUP. MANICO	UPPER HANDLE	PARTIE SUP. MANCHERON	OBERHOLM	1
21	81002057/0	ASS. CAPOTTINA	COVER ASS.Y	ENS. CAPOT	KOMPLETTE HAUBE	1
21A	81002059/0	ASS. CAPOTTINA	COVER ASS.Y	ENS. CAPOT	KOMPLETTE HAUBE	1
22	12728680/0	VITE	SCREW	VIS	SCHRAUBE	2

—	81008596/0	DOTAZIONE VITERIA	SCREWS OUTFIT	DOTATION VISSERIE	SCHRAUBEN SATZ	1
---	------------	-------------------	---------------	-------------------	----------------	---

T-3614B	VARIANTE REGOLAZIONE MANICO	HANDLE ADJUSTMENT VARIANT	VARIANTE REGLAGE POIGNEE	GRIFFEINSTELLVARIANTE		
51	81006510/0	PARTE INFR. MANICO	LOWER HANDLE	PARTIE INF. MANCHERON	UNTERHOLM	1
52	22785081/0	SUPPORTO ESTERNO	EXTERNAL SUPPORT	SUPPORT EXTERNE	AUßENHALTERUNG	2
53	22785082/0	SUPPORTO INTERNO DX	RH INTERNAL SUPPORT	SUPPORT INTERNE DRDIT	INNENHALTERUNG RECHTS	1
54	22785083/0	SUPPORTO INTERNO SX	LH INTERNAL SUPPORT	SUPPORT INTERNE GAUCHE	INNENHALTERUNG LINKS	1
56	22551575/0	PIASTRINA INTERNA	INSIDE PLAQUE	PLAQUETTE INTERNE	ISOLIER PLATTE	2
57	12793701/0	VITE	SCREW	VIS	SCHRAUBE	2
58	12155000/0	DADO	NUT	ECROU	MUTTER	2
59	12521350/0	RONDELLA	WASHER	RONDELLE	SCHEIBE	2
60	12691810/0	VITE	SCREW	VIS	SCHRAUBE	2
61	22399803/0	MANOPOLINA	KNOB	POIGNÉE	GRIF	2
62	12293202/0	DADO	NUT	ECROU	MUTTER	2
63	12000930/0	ANELLO ELASTICO	SNAP RING	ANNEAU RESSORT	SPRENGRING	1
—	81008622/0	DOTAZ. VITERIA	SCREWS OUTFIT	DOTATION VISSERIE	SCHRAUBEN SATZ	1

**RUOTE E REGOLAZIONE
WHEELS AND HEIGHT ADJUSTING
ROUES ET REGLAGE HAUTEUR DE COUPE
RÄDER UND SCHNITTVERSTELLUNG**

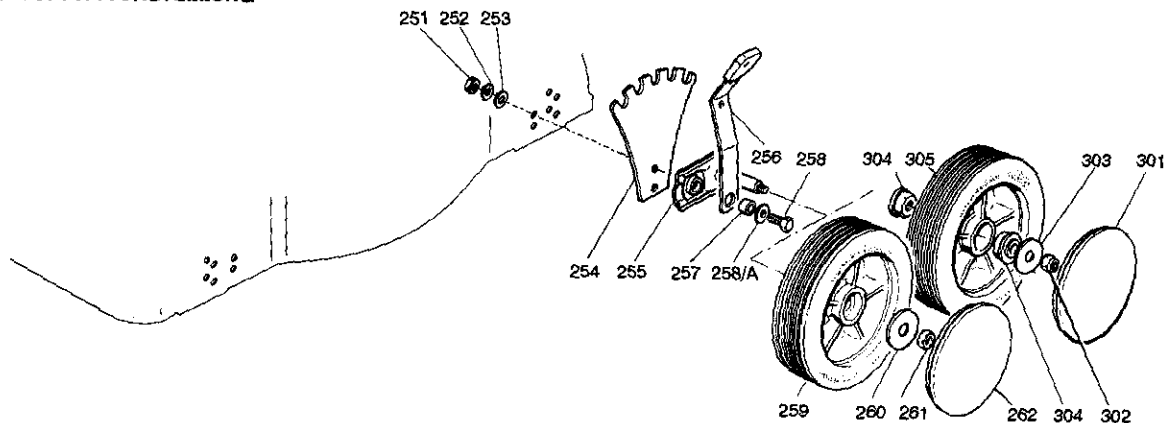

D-3614F

T-3614F

251	12293200/0	DADO	NUT	ECROU	MUTTER	4
252	12583500/0	GROWER	GROWER	GROWER	FEDERRING	4
253	12523070/0	RONDELLA	WASHER	RONDELLE	SCHEIBE	4
254	22735537/0	SETTORE REGOLAZIONE	ADJUSTMENT SECTOR	SECTEUR REGLAGE	VERSTELLUNGSEKTOR	4
255	81005082/0	SUPPORTO RUOTA	WHEEL SUPPORT	SUPPORT ROUE	RADHALTER	4
256	81003273/0	LEVA REGOLAZIONE	ADJUSTMENT LEVER	LEVIER REGLAGE	VERSTELLUNGHEBEL	4
257	22171001/0	DISTANZIALE	SPACER	ENTRETOISE	DISTANZRING	4
258	12793701/0	VITE	SCREW	VIS	SCHRAUBE	4
258A	12521350/0	RONDELLA	WASHER	RONDELLE	SCHEIBE	4
259	81007325/0	RUOTA Ø 170	WHEEL Ø 170	ROUE Ø 170	RAD Ø 170	4
260	12523060/0	RONDELLA	WASHER	RONDELLE	SCHEIBE	4
261	12293201/0	DADO	NUT	ECROU	MUTTER	4
262	22110262/0	COPRIMOZZO BIANCO	WHITE HUB CAP	COUVRE-MOYEU BLANC	WEIßE RADKAPPE	4
—	22110263/0	COPRIMOZZO GIALLO	YELLOW HU BCAP	COUVRE-MOYEU JAUNE	GELBE RADKAPPE	4
—	22110264/0	COPRIMOZZO ROSSO	RED HU BCAP	COUVRE-MOYEU ROUGE	ROTE RADKAPPE	4

Pos. Nr.	Codice Kodex Code	Descrizione	Description	Description	Beschreibung	Q.tà Q.ty Q.tè Menge
T-3614/G		VARIANTI RUOTE Ø 170 SU BOCCOLE	WHEELS Ø 170 VARIANTS ON BUSHES	VARIANTES ROUES Ø 170 SUR DOUILLES	ÄNDERUNGEN AUF RÄDER Ø 170 MIT BÜCHSEN	
301	22110262/0	COPRIMOZZO BIANCO	WHITE HUB CAP	COUVRE-MOYEU BLANC	WEIßE RADKAPPE	4
—	22110263/0	COPRIMOZZO GIALLO	YELLOW HU BCAP	COUVRE-MOYEU JAUNE	GELBE RADKAPPE	4
—	22110264/0	COPRIMOZZO ROSSO	RED HU BCAP	COUVRE-MOYEU ROUGE	ROTE RADKAPPE	4
302	12155000/0	DADO	NUT	ECROU	MUTTER	4
303	12523060/0	RONDELLA	WASHER	RONDELLE	SCHEIBE	4
304	22034508/0	BOCCOLA	BUSCHING	DOUILLE	BÜCHSE	8
305	81007326/0	RUOTA Ø 170	WHEEL Ø 170	ROUE Ø 170	RAD Ø 170	4

VARIANTE REGOLAZIONE RUOTE

WHEEL ADJUSTMENT VARIANT

VARIANTE REGLAGE ROUES

RADEINSTELLVARIANTE

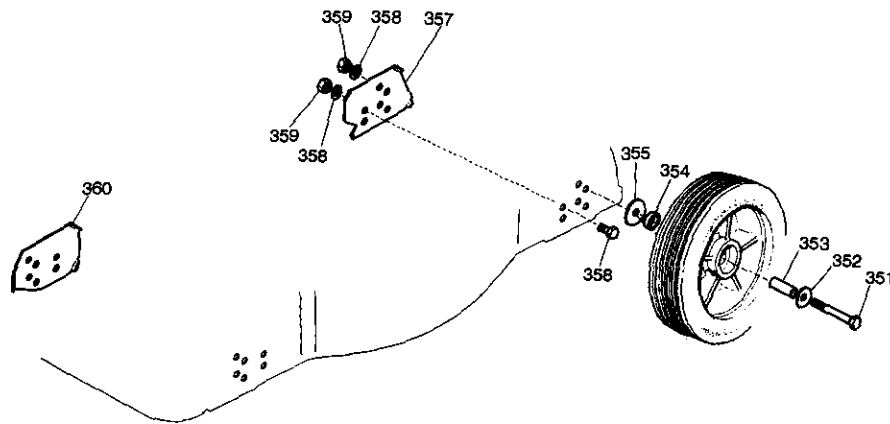

Pos. Nr.	Codice Kodex Code	Descrizione	Description	Description	Beschreibung	Q.tà Q.ty Q.tè Menge
T-3614/H				D-3614/H		
351	12691900/0	VITE	SCREW	VIS	SCHRAUBE	4
352	12523060/0	RONDELLA	WASHER	RONDELLE	SCHEIBE	4
353	22869650/0	TUBO PER RUOTA	WHEEL TUBE	TUBE POUR ROUE	ROHR FÜR RAD	4
354	22172420/0	DISTANZIALE	SPACER	ENTRETOISE	DISTANZRING	4
355	12523070/0	RONDELLA	WASHER	RONDELLE	SCHEIBE	4
356	12792611/0	VITE	SCREW	VIS	SCHRAUBE	4
357	22551513/0	PIASTRA POSTERIORE	BACK PLATE	PLAQUE POSTÉRIEURE	HINTERPLATTE	2
358	12583500/0	GROWER	GROWER	GROWER	GROWER	8
359	12293200/0	DADO	NUT	ECROU	MUTTER	8
360	22551511/0	PIASTRA ANTERIORE	FRONT PLATE	PLAQUE ANTÉRIEURE	VORDERPLATTE	2

**GRUPPO MOTORE ELETTRICO
MOTOR ASS.Y
MOTEUR ELECTRIQUE
ELEKTROMOTOR**

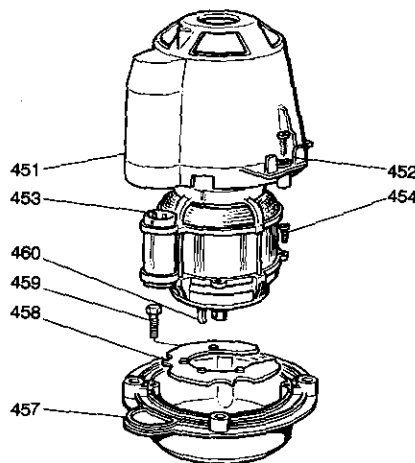

Pos. Nr.	Codice Kodex Code	Descrizione	Description	Description	Beschreibung	Q.tà Q.ty Q.tè Menge
T-3614/L						
451	22785061/0	SUPPORTO CAPOTTINA	COVER SUPPORT	SUPPORT CAPOT	HAUBEHALTER	1
452	12728710/0	VITE	SCREW	VIS	SCHRAUBE	4
453		MOTORE	MOTOR	MOTEUR	MOTOR	
—	18563068/1	IBMEI 1300W (230V)	IBMEI 1300W (230V)	IBMEI 1300W (230V)	IBMEI 1300W (230V)	1
—	18563008/0	RST 1300W (220-230V)	RST 1300W (220-230V)	RST 1300W (220-230V)	RST 1300W (220-230V)	1
—	18563069/1	IBMEI 1300W (240V)	IBMEI 1300W (240V)	IBMEI 1300W (240V)	IBMEI 1300W (240V)	1
—	18563061/2	IBMEI 1600W (230V)	IBMEI 1600W (230V)	IBMEI 1600W (230V)	IBMEI 1600W (230V)	1
—	18563009/0	RST 1600W (230V)	RST 1600W (230V)	RST 1600W (230V)	RST 1600W (230V)	1
—	18563047/2	IBMEI 1600W (240V)	IBMEI 1600W (240V)	IBMEI 1600W (240V)	IBMEI 1600W (240V)	1
453A	18740049/0	VENTOLA PER MOTORE	MOTOR FAN	VENTILATEUR MOTEUR	LÜFTER	1

Pos. Nr.	Codice Kodex Code	Descrizione	Description	Description	Beschreibung	Q.tà Q.ty Q.té Menge
—	16740051/0	VENTOLA PER MOTORE RST	RST MOTOR FAN	VENTILATEUR MOTEUR RST	RST LÜFTER	1
453B	16222037/0	CONDENSATORE 16 µF	CONDENSER 16 µF	CONDENSEUR 16 µF	KONDENSATOR 16 µF	1
—	18222038/0	CONDENSATORE 20 µF	CONDENSER 20 µF	CONDENSEUR 20 µF	KONDENSATOR 20 µF	1
454	12735410/0	VITE	SCREW	VIS	SCHRAUBE	4
455	12583500/0	GROWER	GRDWER	GROWER	FEDERRING	4
456	12293200/0	DADO	NUT	ECROU	MUTTER	4
457	22207211/3	FLANGIA	FLANGE	BRIDE	FLANSCH	1
458	22720360/1	SCHERMO VENTILAZIONE	VENTILATION SCREEN	ECRAN VENTILATION	LÜFTUNGSSCHIRM	1
459	12793700/0	VITE	SCREW	VIS	SCHRAUBE	4
460	12139440/0	LINGUETTA	FEATHER	CLAVETTE	KEIL	1

**GRUPPO COLTELLO
BLADE ASS.Y
GROUPE LAMES
MESSERSATZ**

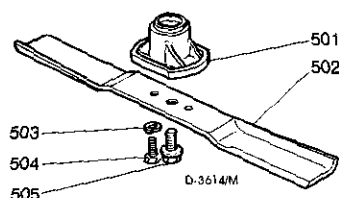

T-3621/M

501	22463186/1	MOZZO	HUB	MOYEU	NABE	1
502	81004341/2	COLTELLO STANDARD 41 cm.	STANDARD BLADE 41 cm.	LAME STANDARD 41 cm.	STANDARD MESSER 41 cm.	1
—	81004396/0	COLTELLD ALETTATO 41 cm.	WINGED BLADE 41 cm.	LAME AILETTÉE 41 cm.	FLÜGELMESSER 41 cm.	1
—	81004346/2	COLTELLO STANDARD 46 cm.	STANDARD BLADE 46 cm.	LAME STANDARD 46 cm.	STANDARD MESSER 46 cm.	1
—	81004397/0	COLTELLO ALETTATO 46 cm.	WINGED BLADE 46 cm.	LAME AILETTÉE 46 cm.	FLÜGELMESSER 46 cm.	1
503	12583500/0	GROWER	GROWER	GROWER	FEDERRING	2
504	12793101/0	VITE	SCREW	VIS	SCHRAUBE	2
505	81004352/0	VITE	SCREW	VIS	SCHRAUBE	1

**SACCO RACCOGLIERBA
GRASS-CATCHER
BAC DE RAMASSAGE
GRASFANGKORB**

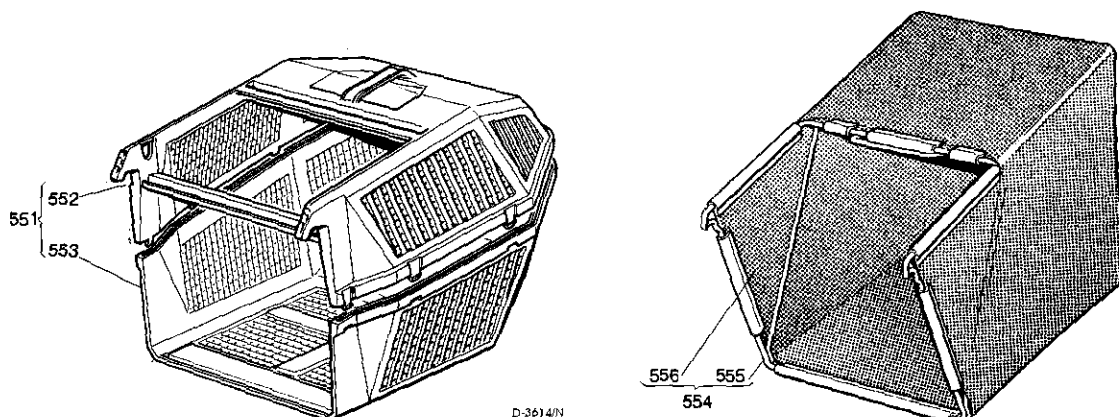

T-3614/N

551	98005000/1	SACCO COMPLETO	COMPLETE GRASS-BOX	SAC COMPLET	KOMPLETTER KORB	1
552	22486076/0	PORTE SUP. SACCO	UPPER GRASS BOX	PARTIE SUP. SAC	OBERKORB	1
553	22486077/0	PORTE INF. SACCO	LOWER GRASS BOX	PARTIE INF. SAC	UNTERKORB	1
554	98004000/0	ASS. SACCO IN TELA	CANVASS GRASSCATCHER	ENSEMBLE SAC EN TOILE	KOMPLETTER SACK	1
555	81006408/0	TELAIO	CHASSIS	CHÂSSIS	RAHMEN.	1
556	81002105/2	TELA SACCO	FABRIC BOX	TOILE POUR SAC	TUCK FÜR SACK	1